



SERIE

**K**

**CILINDRI COMPATTI**  
**COMPACT CYLINDERS**

  
**ARTEC**<sup>®</sup>  
PNEUMATIC COMPONENTS

### CARATTERISTICHE TECNICHE - TECHNICAL CHARACTERISTICS

<b>Pressione di esercizio</b> <i>Working pressure</i>	1 ÷ 10 bar (doppio effetto - <i>double acting</i> ) 2 ÷ 10 bar (semplice effetto - <i>single acting</i> )
<b>Temperatura di esercizio</b> <i>Working temperature</i>	0 ÷ +80°C (-20°C con aria secca - <i>with dry air</i> ) 0 ÷ +150°C (con guarnizioni per alte temperature - <i>with high temperature seals</i> )
<b>Versioni - Versions</b>	semplice effetto (molla anteriore) - doppio effetto - antirotazione - stelo passante <i>single acting (front spring) - double acting - anti-rotation - double rod</i>
<b>Alesaggi - Bores</b>	∅ 125 - 160 - 200 - 250
<b>Corse - Strokes</b>	vedere tabelle corse standard - <i>see standard stroke tables</i>
<b>Fluido - Fluid</b>	aria compressa filtrata, non lubrificata - <i>compressed filtered, non lubricated air</i>

### CARATTERISTICHE COSTRUTTIVE - CONSTRUCTIVE CHARACTERISTICS

①	<b>Stelo - Rod</b>	acciaio inox AISI 303 - <i>stainless steel AISI 303</i>
② ①①	<b>Guarnizioni - Seals</b>	poliuretano - <i>polyurethane</i>
③	<b>Boccola - Bush</b>	ottone - <i>brass</i>
④ ⑫	<b>Testate - Covers</b>	alluminio anodizzato - <i>anodized aluminium</i>
⑤	<b>O-ring</b>	NBR
⑥	<b>Tubo - Tube</b>	alluminio anodizzato - <i>anodized aluminium</i>
⑦	<b>Paracolpo - Bumper</b>	NBR
⑧	<b>Pistone - Piston</b>	alluminio - <i>aluminium</i>
⑨	<b>Fascia di guida - Guide ring</b>	PBT+PTFE
⑩	<b>Magnete - Magnet</b>	plastoferrite - <i>rubber magnet</i>
	<b>Tiranti - Tie rods</b>	acciaio - <i>steel</i>
	<b>Viti - Screws</b>	acciaio - <i>steel</i>
	<b>Molla - Spring</b>	acciaio - <i>steel</i>

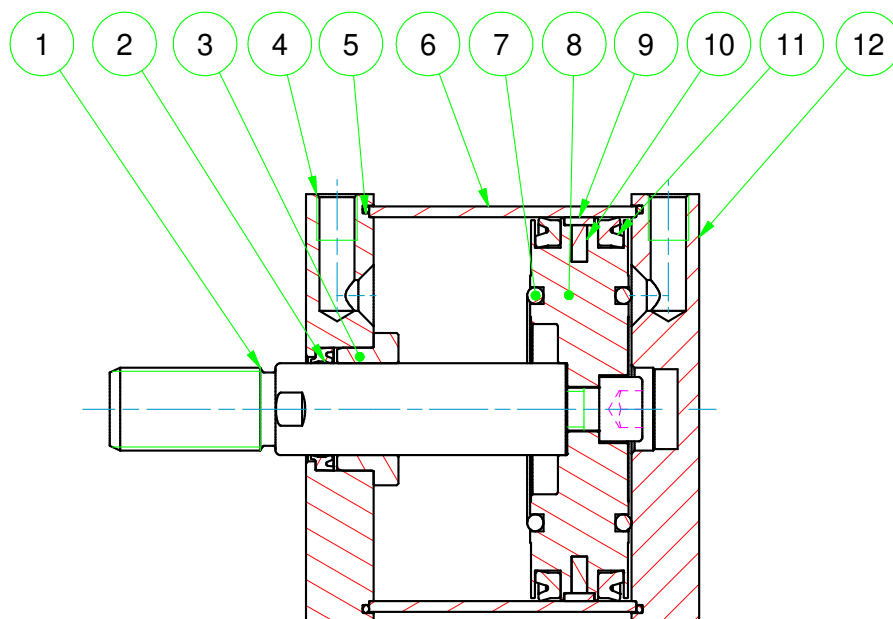

## CHIAVE DI CODIFICA

### KEY CODE

<b>K</b>	<b>D</b>	<b>M</b>	<b>2</b>	<b>0</b>	<b>0</b>	<b>.</b>	<b>1</b>	<b>0</b>	<b>0</b>	<b>.</b>	<b>G</b>	<b>S</b>	<b>.</b>	<b>F</b>
			<b>ALESAGGIO - BORE (Ø)</b>		<b>CORSA - STROKE (mm)</b>			<b>OPZIONE - OPTION</b>						
			125 - 160 - 200 - 250		vedere tabelle corse std see std stroke tables			EX ATEX  II 2GD c T4						
			<b>VERSIONE - VERSION</b>					<b>STELO - ROD</b>						
			<b>P</b> stelo passante double rod  <b>A</b> con staffa antirotazione with anti-rotation bracket					<b>F</b> femmina female  <b>M</b> maschio male						
			<b>VERSIONE - VERSION</b>					<b>GUARNIZIONI - SEALS</b>						
			<b>M</b> magnetico magnetic  non magnetico non-magnetic					<b>GS</b> guarnizioni standard standard seals  <b>VR</b> guarnizione stelo per alte temperature high temperature rod seal  <b>VA</b> tutte le guarnizioni per alte temperature all seals for high temperature						
			<b>VERSIONE - VERSION</b>											
			<b>S</b> semplice effetto molla anteriore single acting front spring  <b>D</b> doppio effetto double acting											
			<b>SERIE - SERIES</b>											
			<b>K</b> tubo tondo con tiranti round tube with tie rods											

SERIE

**K**

Cilindri tandem vedi pagina 322

Tandem cylinders see page 322

### ESECUZIONI A RICHIESTA - ON REQUEST

 Stelo forato - *Hollow rod*

 Stelo prolungato (W) - *Extended rod (W)*

 Filetti speciali (dado stelo non fornito) - *Special thread (without rod nut)*

ATEX II 2GD c T4

### FORZE TEORICHE DI TRAZIONE (P=6bar)

#### THEORETICAL FORCES OF TRACTION (P=6bar)

		Ø	125	160	200	250
<b>KD - KDM</b>	SPINTA THRUST	[N]	7.363	12.064	18.850	29.452
	TRAZIONE TRACTION	[N]	6.940	11.310	18.095	28.700
<b>KDP - KDMP</b>	SPINTA THRUST	[N]	6.940	11.310	18.095	28.700
	TRAZIONE TRACTION	[N]	6.940	11.310	18.095	28.700

**DIAGRAMMA TEORICO CARICO AMMISSIBILE**

**THEORETICAL ALLOWABLE LOAD**

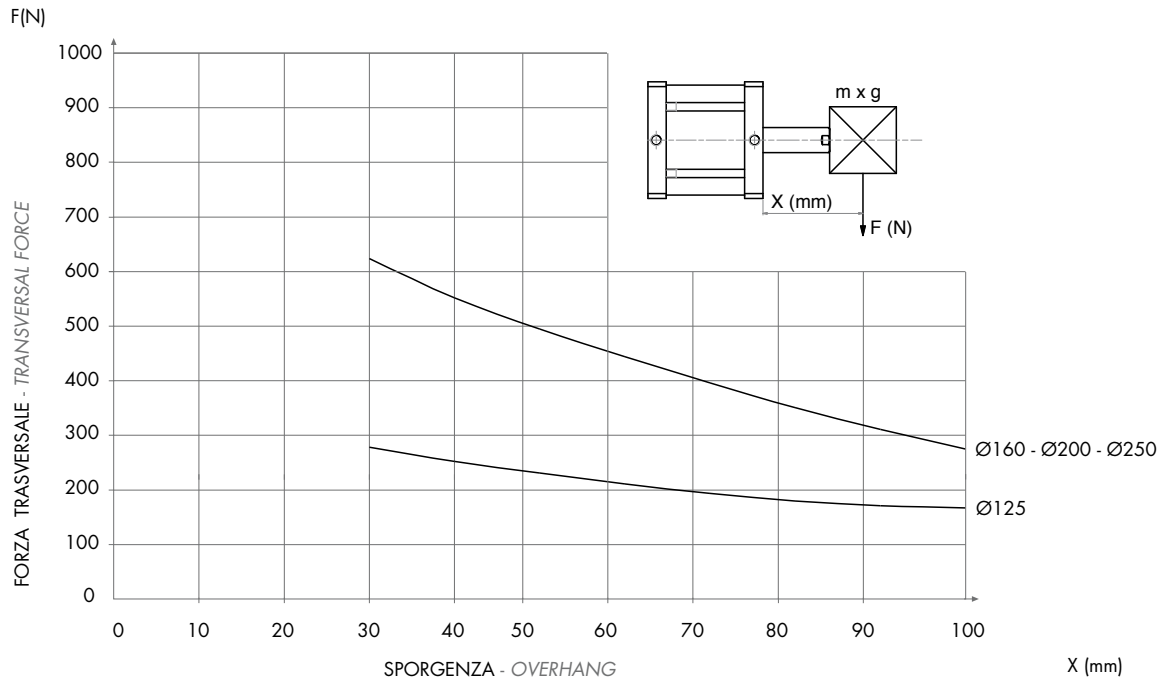

**DIAGRAMMA TEORICO CARICO AMMISSIBILE**

**THEORETICAL ALLOWABLE LOAD**

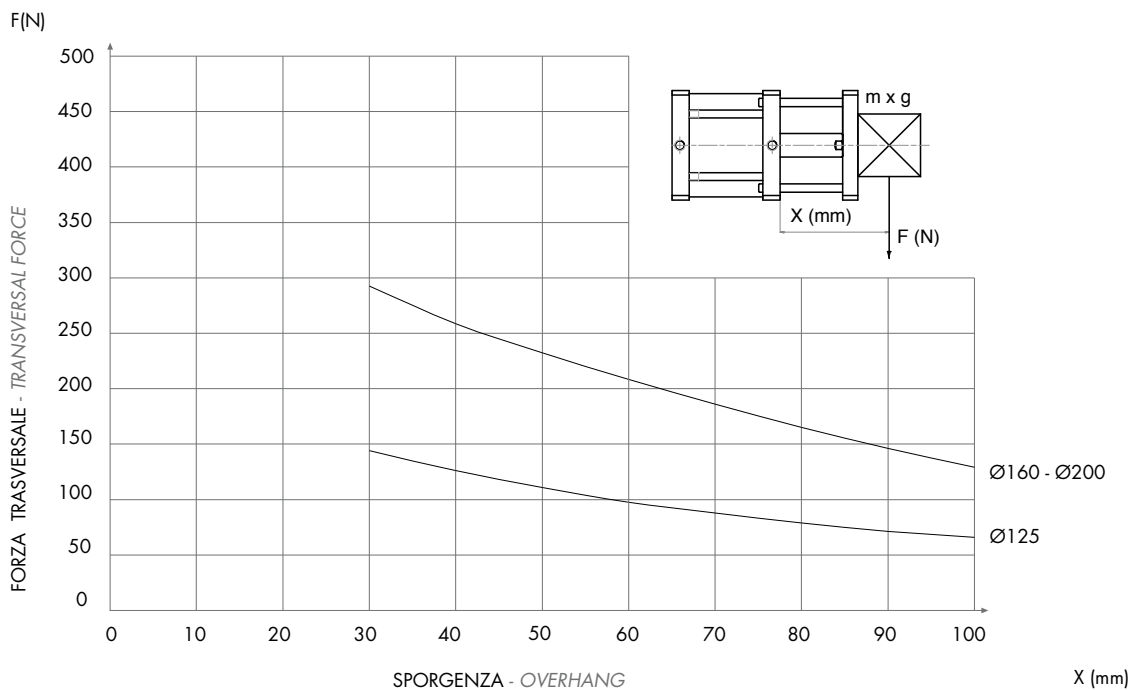

**DIAGRAMMA TEORICO COPPIA AMMISSIBILE**

**THEORETICAL ALLOWABLE TORQUE**

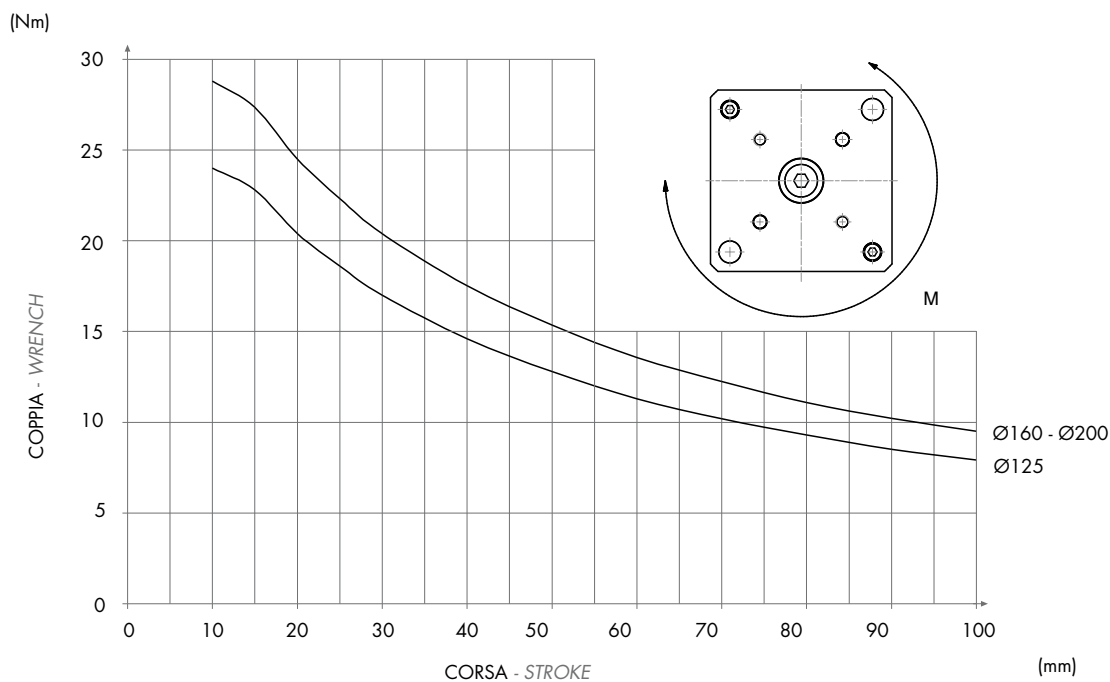

**DIAGRAMMA TEORICO CARICO AMMISSIBILE**

**THEORETICAL ALLOWABLE LOAD**

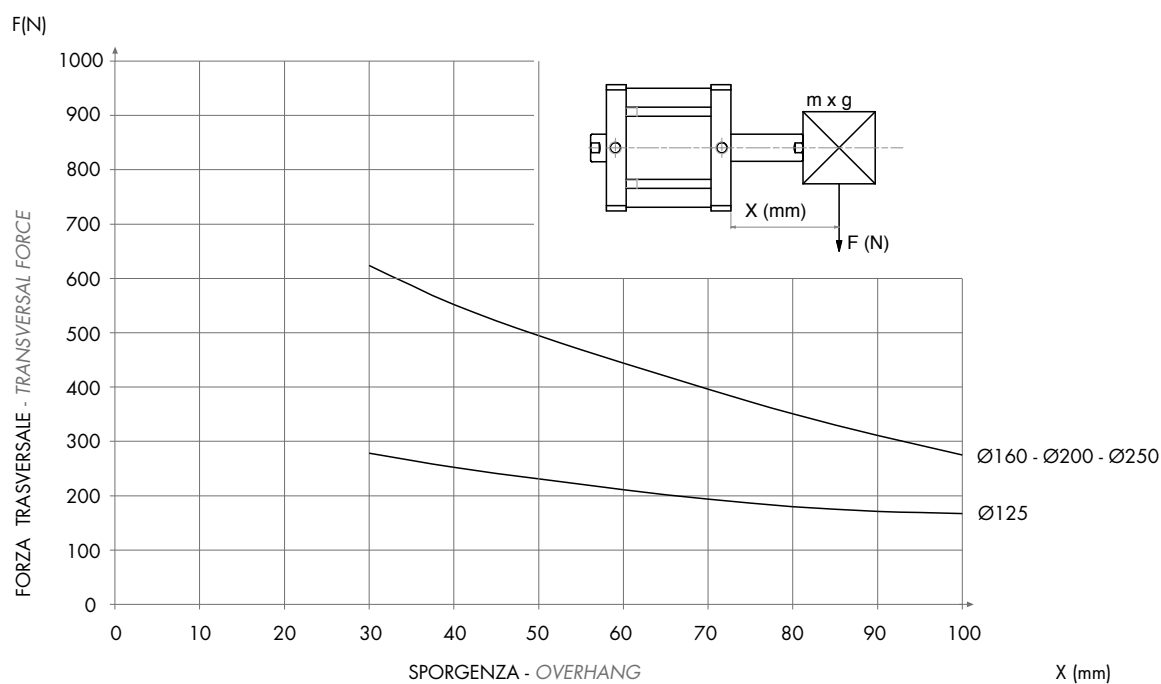

**SEMPLICE EFFETTO (MAGNETICO) - MOLLA ANTERIORE**

SINGLE ACTING (MAGNETIC) - FRONT SPRING

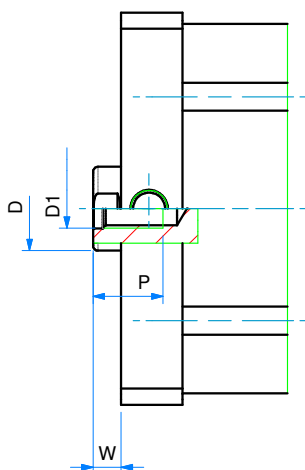
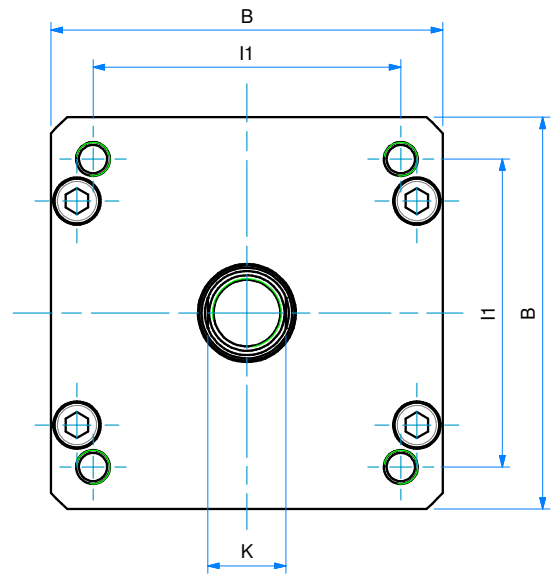
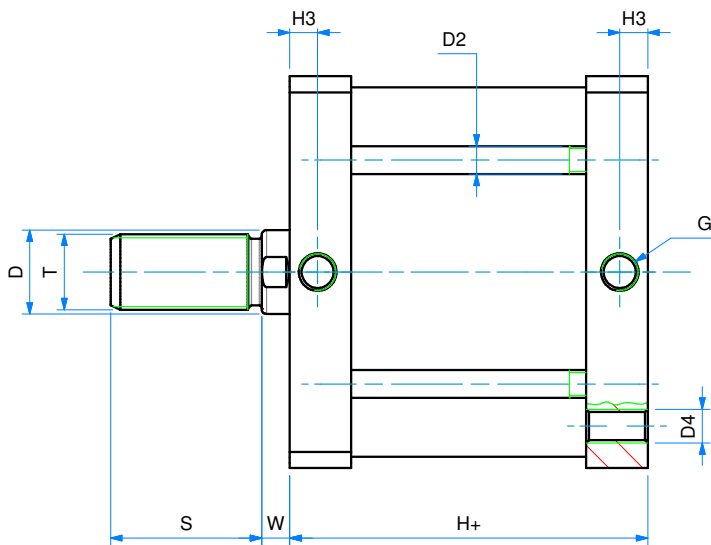
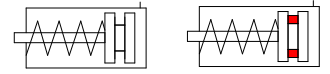

SERIE  
**K**

**DIMENSIONI - DIMENSIONS**

	<b>125</b>	<b>160</b>	<b>200</b>
<b>B</b>	140	180	220
<b>ø D</b>	30	40	40
<b>D1</b>	M14	M20	M20
<b>ø D2</b>	10	12	14
<b>D4</b>	M12	M16	M16
<b>G</b>	G1/4	G3/8	G3/8
<b>H+</b>	78	87	87
<b>H+ viton</b>	83	91	105
<b>H3</b>	10	12	12
<b>I1</b>	110	140	175
<b>K</b>	28	36	36
<b>P</b>	25	30	30
<b>S</b>	54	72	72
<b>T</b>	M27x2	M36x2	M36x2
<b>W</b>	10	12	12

<b>ø</b>	<b>CORSE STANDARD - STANDARD STROKES</b>
<b>125</b>	10 - 25 - 50
<b>160</b>	10 - 25 - 50
<b>200</b>	10 - 25 - 50

+ = aggiungere lunghezza corsa (mm) - add stroke length (mm)

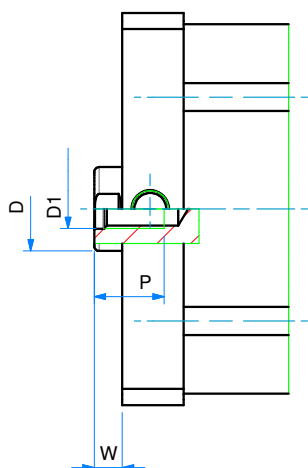
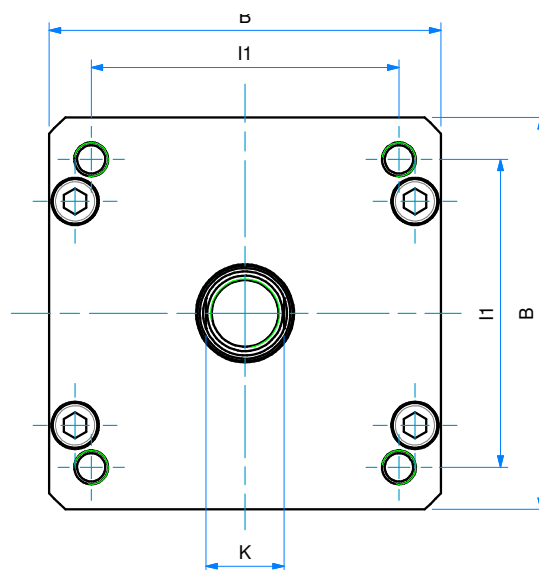
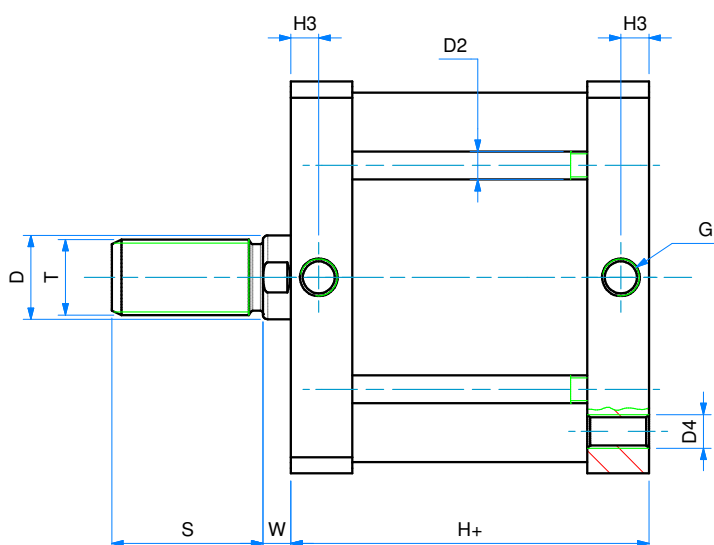
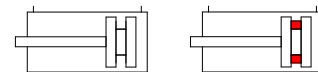
**DOPPIO EFFETTO (MAGNETICO)**
**DOUBLE ACTING (MAGNETIC)**

SERIE

**K**
**DIMENSIONI - DIMENSIONS**

	<b>125</b>	<b>160</b>	<b>200</b>	<b>250</b>
<b>B</b>	140	180	220	270
<b>ø D</b>	30	40	40	40
<b>D1</b>	M14	M20	M20	M24
<b>ø D2</b>	10	12	14	16
<b>D4</b>	M12	M16	M16	M20
<b>G</b>	G1/4	G3/8	G3/8	G1/2
<b>H+</b>	78	87	87	116
<b>H + viton</b>	83	91	105	116
<b>H3</b>	10	12	12	15
<b>I1</b>	110	140	175	220
<b>K</b>	28	36	36	36
<b>P</b>	25	30	30	35
<b>S</b>	54	72	72	72
<b>T</b>	M27x2	M36x2	M36x2	M36x2
<b>W</b>	10	12	12	12

<b>ø</b>	<b>CORSE STANDARD - STANDARD STROKES</b>
<b>125</b>	10 - 25 - 50 - 75 - 100 - 125 - 160 - 200 - 250 - 300
<b>160</b>	10 - 25 - 50 - 75 - 100 - 125 - 160 - 200 - 250 - 300
<b>200</b>	10 - 25 - 50 - 75 - 100 - 125 - 160 - 200 - 250 - 300
<b>250</b>	10 - 25 - 50 - 75 - 100 - 125 - 160 - 200 - 250 - 300

+ = aggiungere lunghezza corsa (mm) - add stroke length (mm)

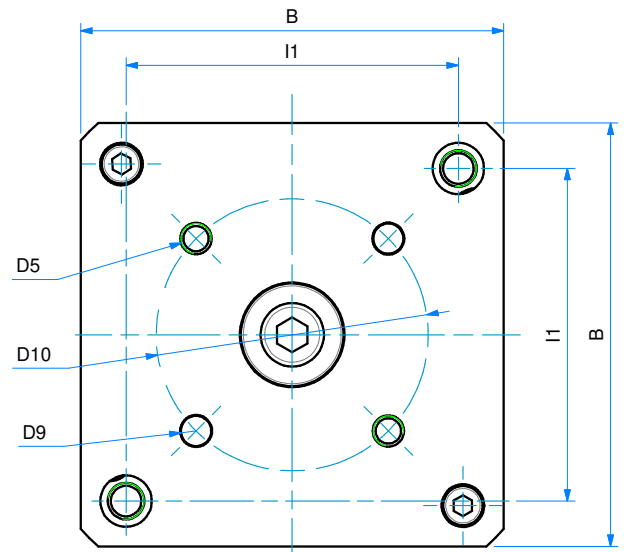
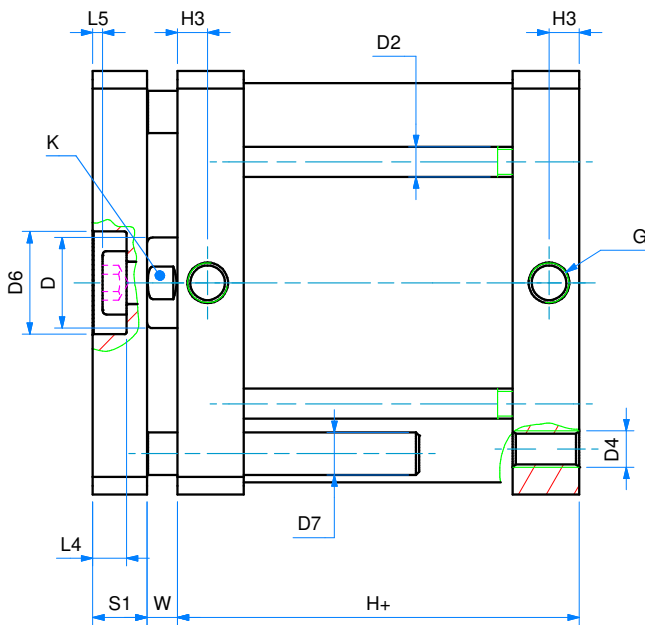
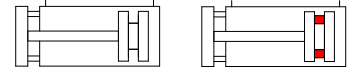
**DOPPIO EFFETTO (MAGNETICO) ANTIROTAZIONE**
**DOUBLE ACTING (MAGNETIC) ANTI-ROTATION**

**SERIE  
K**
**DIMENSIONI - DIMENSIONS**

Ø	125	160	200
<b>B</b>	140	180	220
<b>Ø D</b>	30	40	40
<b>D1</b>	M14	M20	M20
<b>Ø D2</b>	10	12	14
<b>D4</b>	M12	M16	M16
<b>D5</b>	M10	M12	M12
<b>Ø D6</b>	34	46	46
<b>Ø D7</b>	14	20	20
<b>Ø D9</b>	10	12	12
<b>Ø D10</b>	90	110	110
<b>G</b>	G1/4	G3/8	G3/8
<b>H+</b>	78	87	87
<b>H + viton</b>	83	91	105
<b>H3</b>	10	12	12
<b>I1</b>	110	140	175
<b>K</b>	28	36	36
<b>L4</b>	12	16	16
<b>L5</b>	3	3	3
<b>S1</b>	18	23	23
<b>W</b>	10	12	12

**Ø CORSE STANDARD - STANDARD STROKES**

<b>125</b>	10 - 25 - 50 - 75 - 100 - 125 - 160 - 200 - 250 - 300
<b>160</b>	10 - 25 - 50 - 75 - 100 - 125 - 160 - 200 - 250 - 300
<b>200</b>	10 - 25 - 50 - 75 - 100 - 125 - 160 - 200 - 250 - 300

+ = aggiungere lunghezza corsa (mm) - add stroke length (mm)

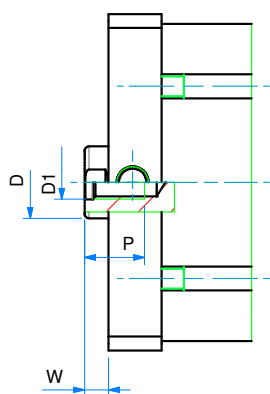
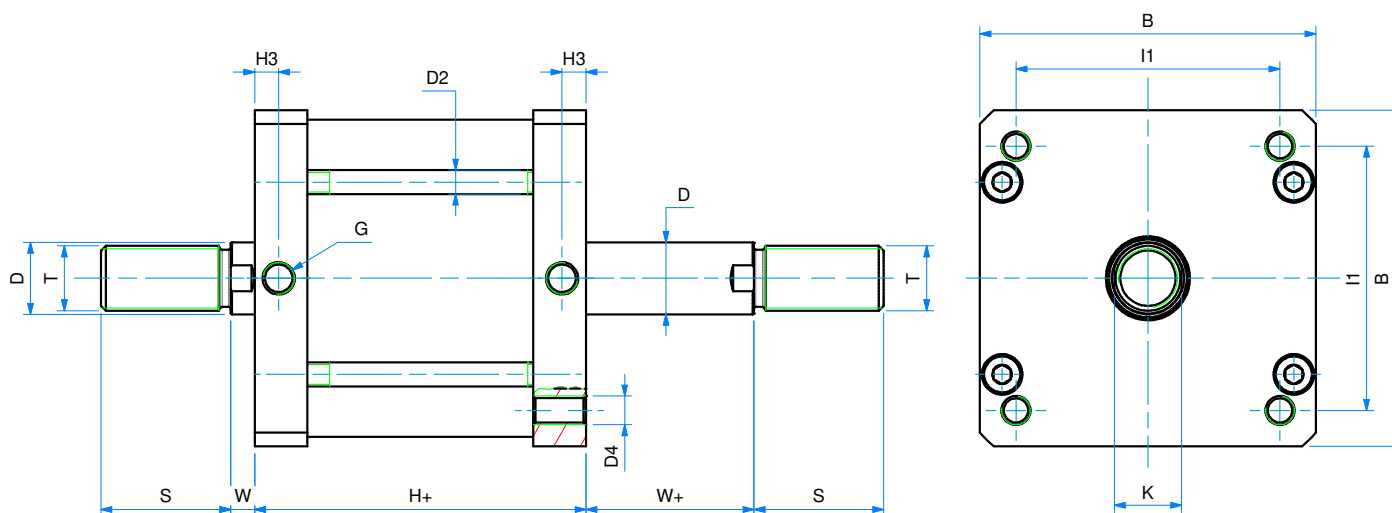

**DOPPIO EFFETTO (MAGNETICO) STELO PASSANTE**
**DOUBLE ACTING (MAGNETIC) WITH DOUBLE ROD**

SERIE

**K**
**DIMENSIONI - DIMENSIONS**

	<b>125</b>	<b>160</b>	<b>200</b>	<b>250</b>
<b>ø</b>	<b>125</b>	<b>160</b>	<b>200</b>	<b>250</b>
<b>B</b>	140	180	220	270
<b>ø D</b>	30	40	40	40
<b>D1</b>	M14	M20	M20	M24
<b>ø D2</b>	10	12	14	16
<b>D4</b>	M12	M16	M16	M20
<b>G</b>	G1/4	G3/8	G3/8	G1/2
<b>H+</b>	78	87	87	116
<b>H + viton</b>	83	91	105	116
<b>H3</b>	10	12	12	15
<b>I1</b>	110	140	175	220
<b>K</b>	28	36	36	36
<b>P</b>	25	30	30	35
<b>S</b>	54	72	72	72
<b>T</b>	M27x2	M36x2	M36x2	M36x2
<b>W</b>	10	12	12	12
<b>W+</b>	10	12	12	12

+ = aggiungere lunghezza corsa (mm) - add stroke length (mm)

<b>ø</b>	<b>CORSE STANDARD - STANDARD STROKES</b>
<b>125</b>	10 - 25 - 50 - 75 - 100 - 125 - 160 - 200 - 250 - 300
<b>160</b>	10 - 25 - 50 - 75 - 100 - 125 - 160 - 200 - 250 - 300
<b>200</b>	10 - 25 - 50 - 75 - 100 - 125 - 160 - 200 - 250 - 300
<b>250</b>	10 - 25 - 50 - 75 - 100 - 125 - 160 - 200 - 250 - 300

## CILINDRI TANDEM - TANDEM CYLINDERS

### CHIAVE DI CODIFICA - KEY CODE

**K T2 M 1 60 . 0 50 . G S . M**

**VERSIONE - VERSION**

<b>T2</b>	tandem doppia spinta double thrust tandem
<b>T3</b>	tandem tripla spinta 3 x force
<b>T4</b>	tandem quadrupla spinta 4 x force

**K C M 1 2 5 . 0 50 . 1 00 . G S . F**

**ALESAGGIO - BORE (Ø)**

125 - 160 - 200 - 250

**I° CORSA (mm)  
I° STROKE (mm)**

vedere tabelle corse std  
see std stroke tables

**II° CORSA (mm)  
II° STROKE (mm)**

vedere tabelle corse std  
see std stroke tables

**STELO - ROD**

<b>F</b>	femmina female
<b>M</b>	maschio male

**VERSIONE - VERSION**

<b>M</b>	magnetico magnetic
	non magnetico non-magnetic

**VERSIONE - VERSION**

<b>P</b>	tandem più posizioni doppio effetto multi-position double acting tandem
<b>C</b>	tandem contrapposti posteriori doppio effetto rear opposed double acting tandem
<b>F</b>	tandem contrapposti anteriori doppio effetto front opposed double acting tandem

**GUARNIZIONI - SEALS**

<b>GS</b>	guarnizioni standard standard seals
<b>VR</b>	guarnizione stelo per alte temperature high temperature rod seal
<b>VA</b>	tutte le guarnizioni per alte temperature all seals for high temperature

**SERIE - SERIES**

<b>K</b>	tubo tondo con tiranti round tube with tie rods
----------	--

**DOPPIA SPINTA - DOUBLE THRUST**

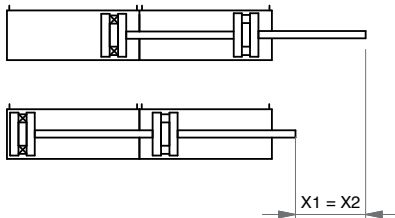

X1= 1° corsa - 1° stroke  
X2= 2° corsa - 2° stroke

**PIÙ POSIZIONI - MULTI-POSITIONS**

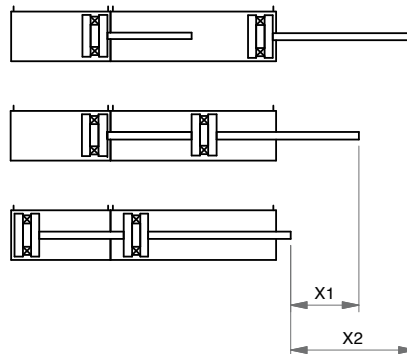

**CONTRAPPOSTI POSTERIORI - REAR OPPOSED**

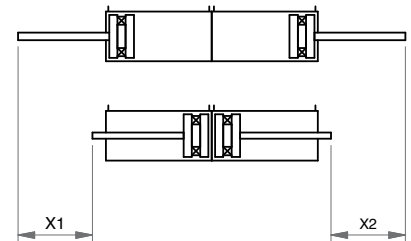

**CONTRAPPOSTI ANTERIORI - FRONT OPPOSED**

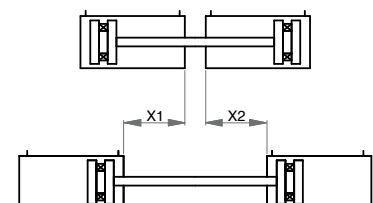

**TANDEM DOPPIA SPINTA D.E.(M)**

DOUBLE THRUST TANDEM D.A.(M)

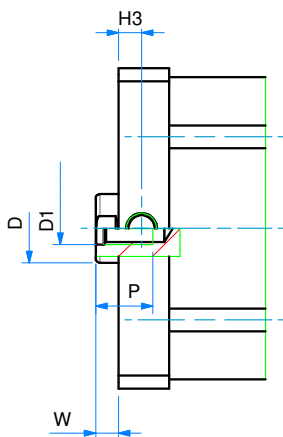
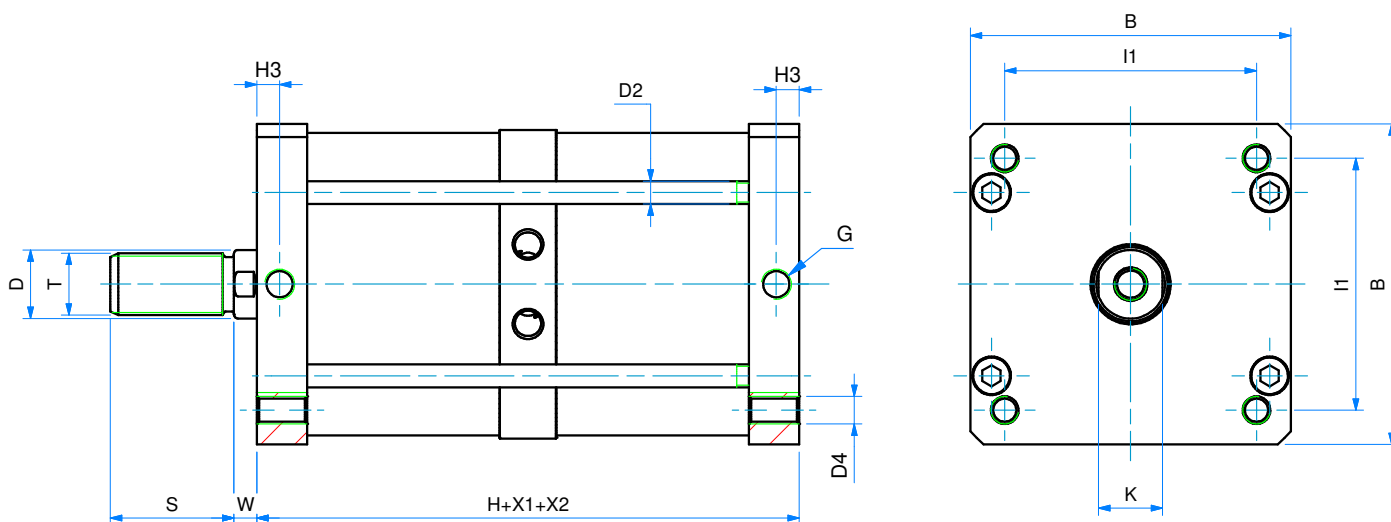
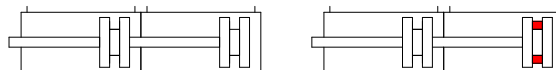

SERIE  
**K**

**DIMENSIONI - DIMENSIONS**

	<b>125</b>	<b>160</b>	<b>200</b>	<b>250</b>
<b>ø</b>	<b>125</b>	<b>160</b>	<b>200</b>	<b>250</b>
<b>B</b>	140	180	220	270
<b>ø D</b>	30	40	40	40
<b>D1</b>	M14	M20	M20	M24
<b>ø D2</b>	10	12	14	M16
<b>D4</b>	M12	M16	M16	M20
<b>G</b>	G1/4	G3/8	G3/8	G1/2
<b>H</b>	137	150	150	202
<b>H viton</b>	147	158	186	202
<b>H3</b>	10	12	12	15
<b>I1</b>	110	140	175	220
<b>K</b>	28	36	36	36
<b>P</b>	25	30	30	35
<b>S</b>	54	72	72	72
<b>T</b>	M27x2	M36x2	M36x2	M36x2
<b>W</b>	10	12	12	12
<b>X1</b>	I° CORSA I° STROKE	I° CORSA I° STROKE	I° CORSA I° STROKE	I° CORSA I° STROKE
<b>X2</b>	II° CORSA II° STROKE	II° CORSA II° STROKE	II° CORSA II° STROKE	II° CORSA II° STROKE

**TANDEM PIÙ POSIZIONI D.E.(M)**

MULTI-POSITION TANDEM D.A.(M)

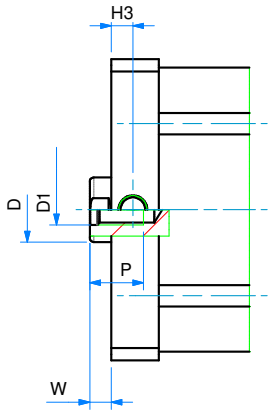
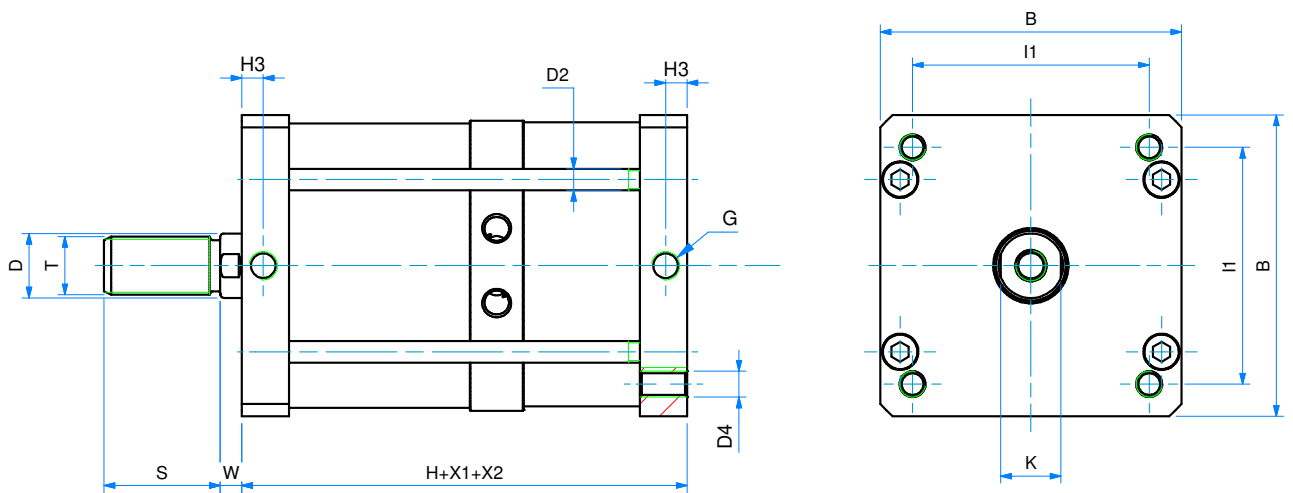
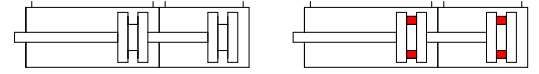

**DIMENSIONI - DIMENSIONS**

	<b>125</b>	<b>160</b>	<b>200</b>	<b>250</b>
<b>B</b>	140	180	220	270
<b>ø D</b>	30	40	40	40
<b>D1</b>	M14	M20	M20	M24
<b>ø D2</b>	10	12	14	M16
<b>D4</b>	M12	M16	M16	M20
<b>G</b>	G1/4	G3/8	G3/8	G1/2
<b>H</b>	137	150	150	202
<b>H viton</b>	137	150	150	202
<b>H3</b>	147	158	186	202
<b>I1</b>	110	140	175	220
<b>K</b>	28	36	36	36
<b>P</b>	25	30	30	35
<b>S</b>	54	72	72	72
<b>T</b>	M27x2	M36x2	M36x2	M36x2
<b>W</b>	10	12	12	12
<b>X1</b>	I° CORSA I° STROKE	I° CORSA I° STROKE	I° CORSA I° STROKE	I° CORSA I° STROKE
<b>X2</b>	II° CORSA II° STROKE	II° CORSA II° STROKE	II° CORSA II° STROKE	II° CORSA II° STROKE

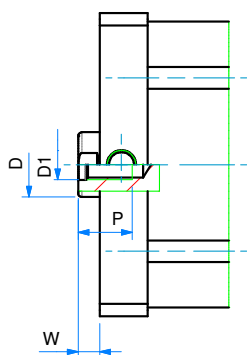
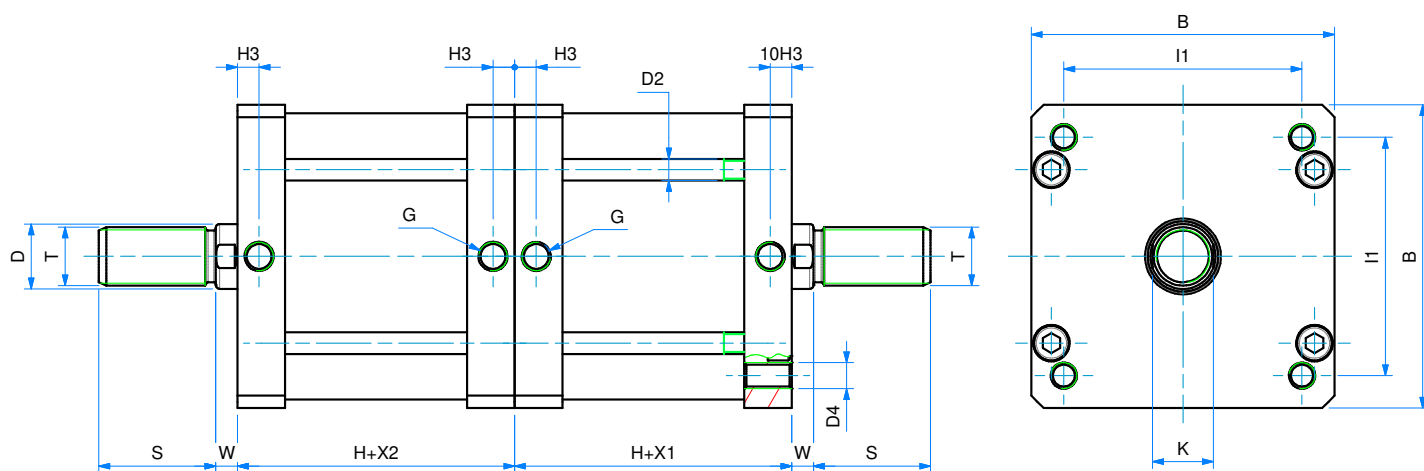
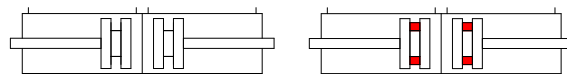
**TANDEM CONTRAPPOSTI POSTERIORI D.E.(M)**
**REAR OPPOSED TANDEM D.A.(M)**

DIMENSIONI - DIMENSIONS				
Ø	125	160	200	250
B	140	180	220	270
Ø D	30	40	40	40
D1	M14	M20	M20	M24
Ø D2	10	20	14	M16
D4	M12	M16	M16	M20
G	G1/4	G3/8	G3/8	G1/2
H	78	87	87	116
H viton	83	91	105	116
H3	10	12	12	15
I1	110	140	175	220
K	28	36	36	36
P	25	30	30	35
S	54	72	72	72
T	M27x2	M36x2	M36x2	M36x2
W	10	12	12	12
X1	I° CORSA I° STROKE	I° CORSA I° STROKE	I° CORSA I° STROKE	I° CORSA I° STROKE
X2	II° CORSA II° STROKE	II° CORSA II° STROKE	II° CORSA II° STROKE	II° CORSA II° STROKE

**SERIE K**

**TANDEM CONTRAPPOSTI ANTERIORI D.E.(M)**

FRONT OPPOSED TANDEM D.A.(M)

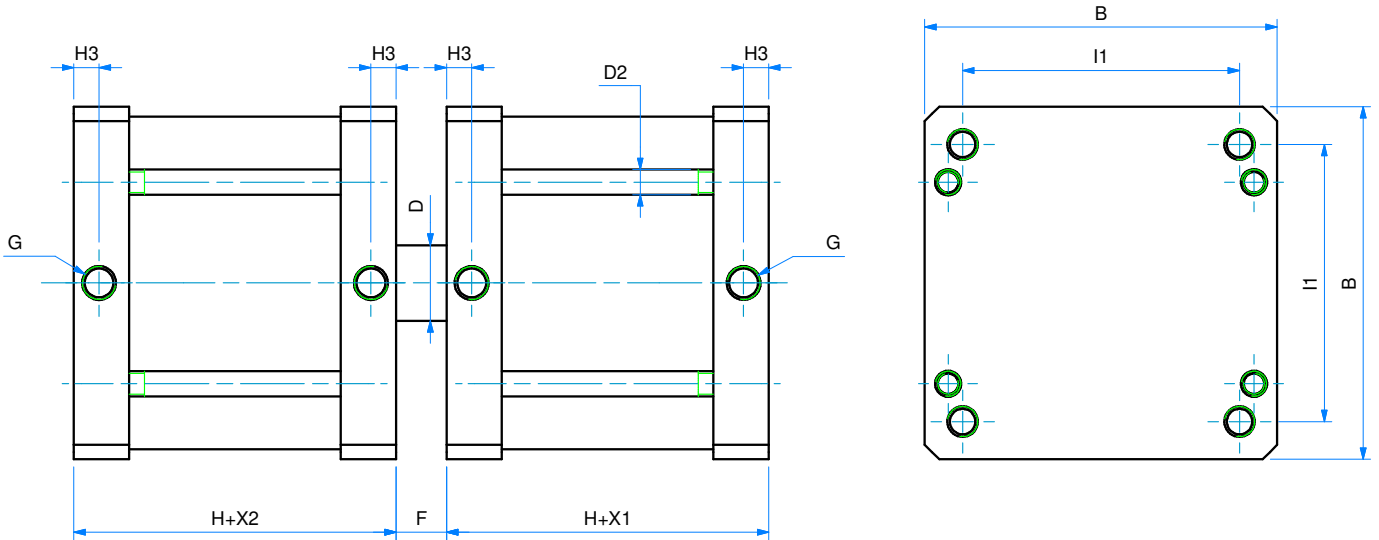
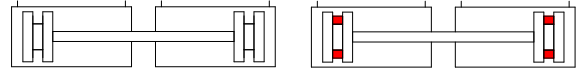

SERIE  
**K**

**DIMENSIONI - DIMENSIONS**

	<b>125</b>	<b>160</b>	<b>200</b>	<b>250</b>
<b>B</b>	140	180	220	270
<b>ø D</b>	30	40	40	40
<b>ø D2</b>	10	12	14	M16
<b>D4</b>	M12	M16	M16	M20
<b>F</b>	20	24	24	24
<b>G</b>	G1/4	G3/8	G3/8	G1/2
<b>H</b>	137	150	150	202
<b>H viton</b>	83	91	105	202
<b>H3</b>	10	12	12	15
<b>I1</b>	110	140	175	220
<b>X1</b>	I° CORSA I° STROKE	I° CORSA I° STROKE	I° CORSA I° STROKE	I° CORSA I° STROKE
<b>X2</b>	II° CORSA II° STROKE	II° CORSA II° STROKE	II° CORSA II° STROKE	II° CORSA II° STROKE

## ACCESSORI DI FISSAGGIO ISO 15552 (UTILIZZABILI ANCHE PER CILINDRI SERIE K)

### ISO 15552 MOUNTING PARTS (ALSO SUITABLE FOR SERIE K CYLINDERS)

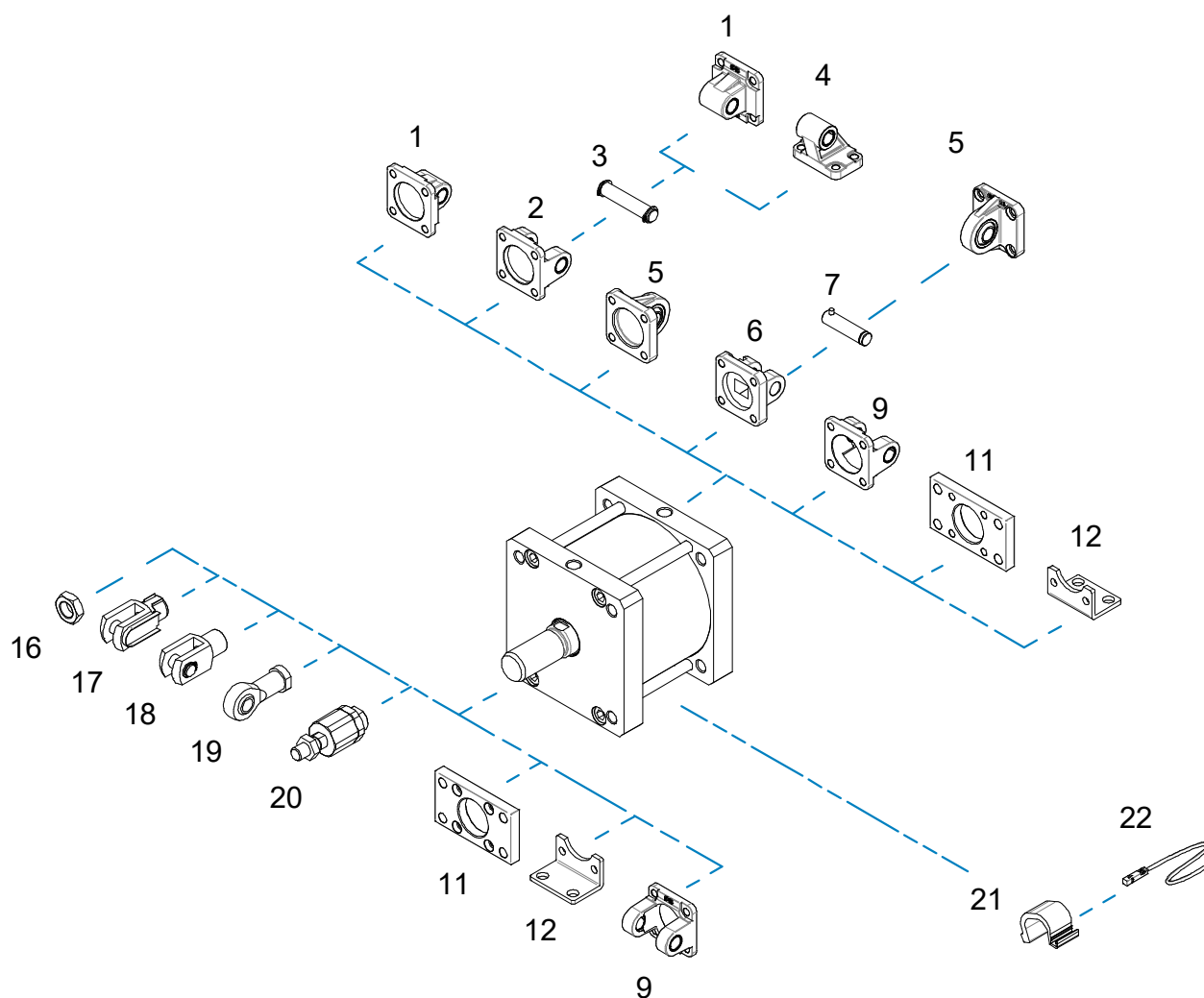

SERIE

**K**

POS.	CODE	DESCRIZIONE-DESCRIPTION
1	CMI---	cerniera maschio iso - iso male hinge
2	CFI---	cerniera femmina iso - iso female hinge
3	PCF---	perno per cerniera - pin for hinge
4	ASI---	articolazione a squadra iso - iso square hinge
5	CMSI---	cerniera maschio snodata iso iso male hinge with ball joint
6	CFSI---	cerniera femmina stretta iso iso narrow female hinge
7	PCFS---	perno per cerniera stretta pin for narrow hinge
9	CFI---F	cerniera femmina forata iso hollow iso female hinge
11	FI---	flangia iso - iso flange
12	PBI---	piedino basso iso - iso foot mounting

POS.	CODE	DESCRIZIONE-DESCRIPTION
16	DA--x---	dado - nut
17	FC--x---	forcella con clips - clevis with lockable pin
18	FP--x---	forcella con perno - clevis with pin
19	SSFI--x---	snodo sferico - rod eye
20	SA--x---	snodo autoallineante - self-aligning joint
21	36.TIR---	adattatore sensore - sensor mounting
22	36.SEN---	sensore magnetico - magnetic sensor

Fissaggi forniti con viti - Mounting parts supplied with screws

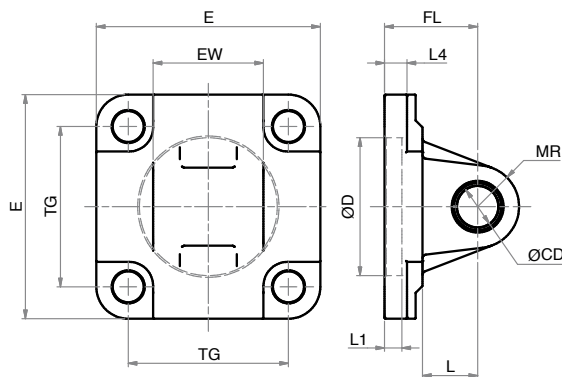
**CERNIERA MASCHIO ISO (MP4)**
**ISO MALE HINGE (MP4)**

LA FORNITURA COMPRENDE:  
 n° 1 CERNIERA MASCHIO  
 n° 4 VITI  
 THE SUPPLY INCLUDES:  
 n° 1 MALE HINGE  
 n° 4 SCREWS

MATERIALE:  
 CORPO IN ALLUMINIO  
 BOCCOLA IN ACCIAIO E PTFE  
 MATERIAL:  
 BODY IN ALUMINIUM  
 BUSH IN STEEL AND PTFE

**DIMENSIONI - DIMENSIONS**

COD.	CMI160	CMI200	CMI250
Ø	160	200	250
EW	90	90	110
E	180	220	270
FL	55	60	70
L1	7	10	11
L4	10	11	17
L	35	35	45
MR	25	25	40
Ø CD	30	30	40
Ø D	65	75	90
TG	140	175	220

SERIE

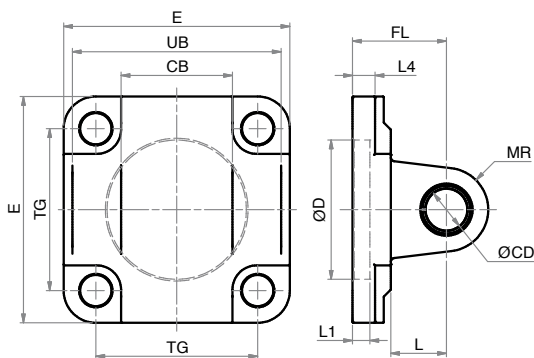
**K**
**CERNIERA FEMMINA ISO (MP2)**
**ISO FEMALE HINGE (MP2)**

LA FORNITURA COMPRENDE:  
 n° 1 CERNIERA FEMMINA  
 n° 4 VITI  
 THE SUPPLY INCLUDES:  
 n° 1 FEMALE HINGE  
 n° 4 SCREWS

MATERIALE:  
 CORPO IN ALLUMINIO  
 BOCCOLA IN ACCIAIO E PTFE  
 MATERIAL:  
 BODY IN ALUMINIUM  
 BUSH IN STEEL AND PTFE

**DIMENSIONI - DIMENSIONS**

COD.	CFI160	CFI200	CFI250
Ø	160	200	250
CB	90	90	110
E	180	220	270
FL	55	60	70
L1	7	7	-
L4	10	10	17
L	35	35	45
MR	25	25	40
Ø CD	30	30	40
Ø D	65	75	90
TG	140	175	220
UB	170	170	200

\*CFI---F dimensione foro centrale uguale alla quota ØD - \*CFI---F dimension of the central hole are the same as ØD

**CFI**
**CFI-F\***

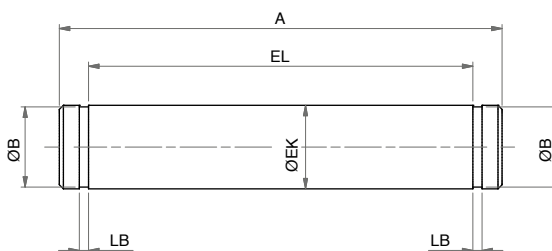

**PERNO PER CERNIERA (AA4)**
**PIN FOR HINGE (AA4)**

LA FORNITURA COMPRENDE:  
 n°1 PERNO  
 n°2 SEEGER  
 THE SUPPLY INCLUDES:  
 n°1 PIN  
 n°2 RETAINING RING

MATERIALE:  
 ACCIAIO ZINCATO  
 MATERIAL:  
 ZINC COATED STEEL

**DIMENSIONI - DIMENSIONS**

COD.	PCF160.200	PCF250
Ø	160-200	250
A	180	211
EL	172	202
LB	1,6	1,85
Ø B	28,6	37,5
Ø EK	30	40

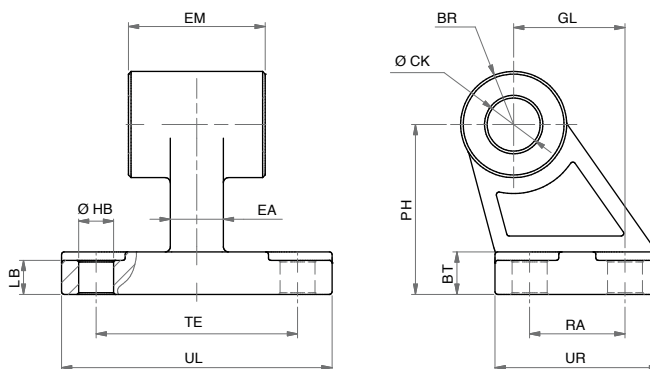
**ARTICOLAZIONE A SQUADRA ISO (AB7)**
**ISO SQUARE HINGE (AB7)**

LA FORNITURA COMPRENDE:  
 n°1 ARTICOLAZIONE A SQUADRA  
 THE SUPPLY INCLUDES:  
 n°1 SQUARE HINGE

MATERIALE:  
 CORPO IN ALLUMINIO  
 BOCCOLA IN ACCIAIO E PTFE  
 MATERIAL:  
 BODY IN ALUMINIUM  
 BUSH IN STEEL AND PTFE

**DIMENSIONI - DIMENSIONS**

COD.	ASI160	ASI200	ASI250
Ø	160	200	250
BR	31,5	31,5	80
BT	25	30	35
Ø CK	30	30	40
EA	36	40	45
EM	90	90	110
GL	97	105	128
LB	21	26	30.5
Ø HB	14	18	22
PH	115	135	165
RA	88	90	110
TE	118	122	150
UL	156	162	200
UR	126	130	160

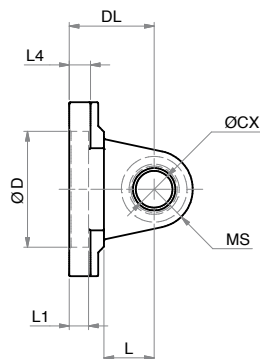
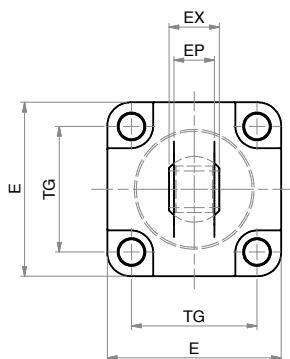
**CERNIERA MASCHIO SNODATA ISO (MP6)**
**ISO MALE HINGE WITH BALL JOINT (MP6)**

LA FORNITURA COMPRENDE:  
 n° 1 CERNIERA MASCHIO  
 n° 4 VITI  
 THE SUPPLY INCLUDES:  
 n° 1 MALE HINGE  
 n° 4 SCREWS

MATERIALE:  
 CORPO IN ALLUMINIO  
 SNODO IN ACCIAIO,  
 BRONZO E PTFE  
 MATERIAL:  
 BODY IN ALUMINIUM  
 EYE IN STEEL, BRONZE AND PTFE

**DIMENSIONI - DIMENSIONS**

COD.	CMSI160	CMSI200
Ø	160	200
DL	55	60
EP	28	28
EX	43	43
E	180	220
L1	7	10
L4	-	-
L	35	35
MS	44	47
Ø CX	35	35
Ø D	65	75
TG	140	175

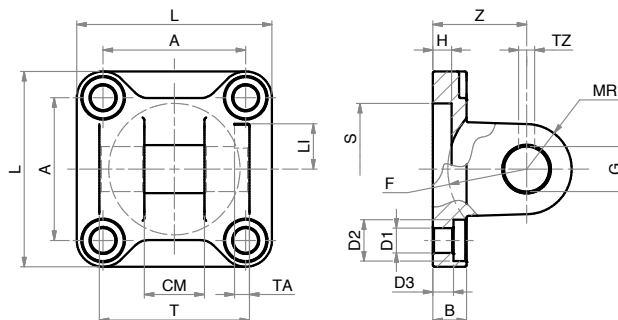
**CERNIERA FEMMINA STRETTA ISO (AB6)**
**ISO NARROW FEMALE HINGE (AB6)**

LA FORNITURA COMPRENDE:  
 n° 1 CERNIERA FEMMINA  
 n° 4 VITI  
 THE SUPPLY INCLUDES:  
 n° 1 FEMALE HINGE  
 n° 4 SCREWS

MATERIALE: ALLUMINO  
 MATERIAL: ALUMINIUM

**DIMENSIONI - DIMENSIONS**

COD.	CFSI160	CFSI200
ø	160	200
A	140	175
B	20	25
CM	43	43
D1	18	18
D2	26	26
D3	10	11
F min.	46	49
G	35	35
H	7	7
LI	26,5	26,5
L	180	220
MR	30	30
S	65	75
TA	6	6
TZ	6,3	6,3
T	122	122
Z	55	60

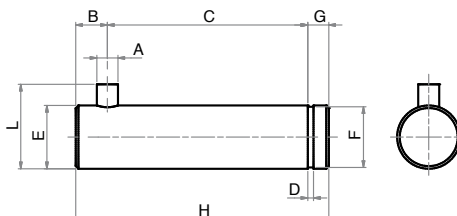
**PERNO PER CERNIERA STRETTA (AA6)**
**PIN FOR NARROW HINGE (AA6)**

LA FORNITURA COMPRENDE:  
 n° 1 PERNO  
 n° 1 SEEGER  
 THE SUPPLY INCLUDES:  
 n° 1 PIN  
 n° 1 RETAINING RING

MATERIALE:  
 ACCIAIO ZINCATO  
 MATERIAL:  
 ZINC COATED STEEL

**DIMENSIONI - DIMENSIONS**

COD.	PCFS160.200
ø	160
A	6
B	9
C	119
D	1,6
E	35
F	33
G	7
H	135
L	41

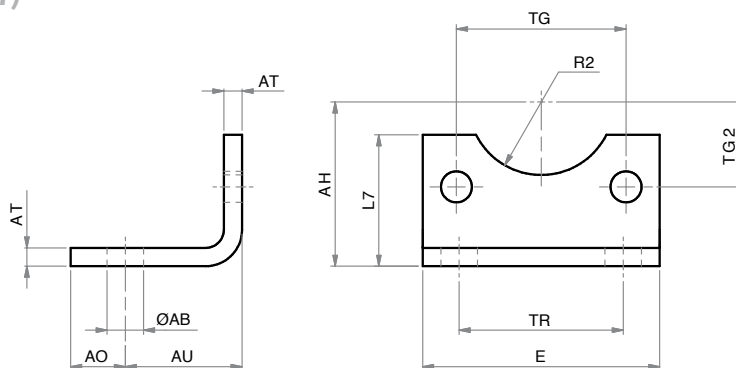
**PIEDINO BASSO ISO (MS1)**
**ISO FOOT MOUNTING (MS1)**

LA FORNITURA COMPRENDE:  
 n° 1 PIEDINO  
 n° 2 VITI  
 THE SUPPLY INCLUDES:  
 n° 1 FOOT MOUNTING  
 n° 2 SCREWS

MATERIALE:  
 ACCIAIO ZINCATO  
 MATERIAL:  
 ZINC COATED STEEL

**DIMENSIONI - DIMENSIONS**

COD.	PBI160	PBI200
ø	160	200
AH	115	135
AO	15	30
AT	10	12
AU	60	70
E	180	220
L7	100	109
ø AB	18,5	24
R2	32,5	37,5
TG2	70	87,5
TG	140	175
TR	115	135

A richiesta - On request Ø 250-320

SERIE

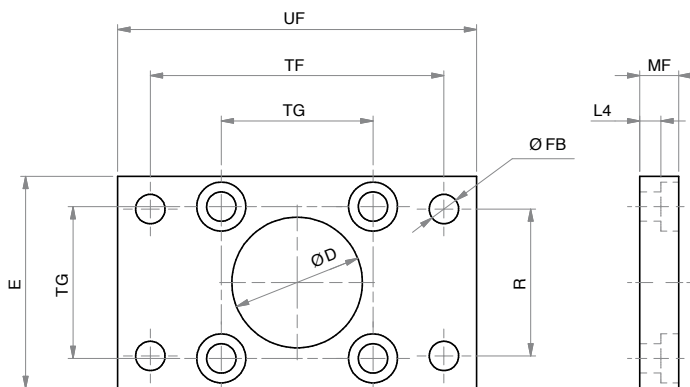
**K**
**FLANGIA ISO (MF1 - MF2)**
**ISO FLANGE (MF1 - MF2)**

LA FORNITURA COMPRENDE:  
 n° 1 FLANGIA  
 n° 4 VITI  
 THE SUPPLY INCLUDES:  
 n° 1 FLANGE  
 n° 4 SCREWS

MATERIALE:  
 ACCIAIO ZINCATO  
 MATERIAL:  
 ZINC COATED STEEL

**DIMENSIONI - DIMENSIONS**

COD.	FI160	FI200	FI250	FI320
ø	160	200	250	320
E	180	220	285	350
L4	9,5	12,5	10,5	15
MF	20	25	25	30
ø D	65	75	90	110
ø FB	18	22	26	33
R	115	135	165	200
TF	230	270	330	400
TG	140	175	220	270
UF	260	300	400	470

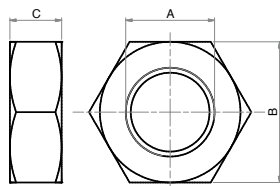
**DADO STELO**
**PISTON ROD NUT**

**DIMENSIONI - DIMENSIONS**

COD.	DA36x2	DA42x2	DA48x2
A	M36x2	M42x2	M48x2
B	55	65	75
C	14	16	18

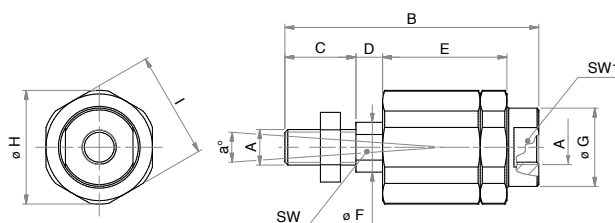
MATERIALE: ACCIAIO ZINCATO  
MATERIAL: ZINC COATED STEEL

**SNODO AUTOALLINEANTE**
**SELF-ALIGNING COUPLING**

**DIMENSIONI - DIMENSIONS**

COD.	SA36x2
A	M36x2
$\alpha^\circ$	8
B	251
C	71
D	22
E	136
$\varnothing F$	36
$\varnothing G$	60
$\varnothing H$	80
I	75
SW	32
SW1	55

LA FORNITURA COMPRENDE:  
n° 1 SNODO AUTOALLINEANTE  
n° 1 DADO  
THE SUPPLY INCLUDES:  
n° 1 SELF ALIGNING  
n° 1 NUT

MATERIALE: ACCIAIO ZINCATO  
MATERIAL: ZINC COATED STEEL

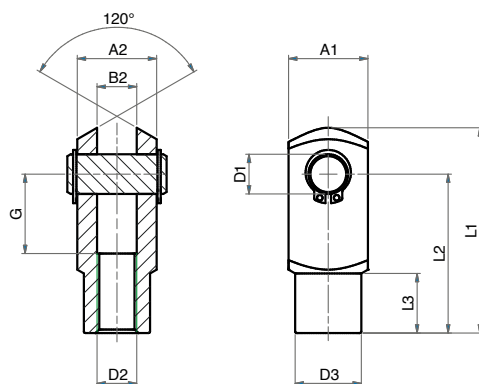
SERIE

**K**
**FORCELLA CON PERNO**
**CLEVIS WITH PIN**

**DIMENSIONI - DIMENSIONS**

COD.	FP36x2	FP42x2	FP48x2
A1	70	85	96
A2	70	85	96
B2	35	40	50
$\varnothing D1$	35	40	50
D2	M36x2	M42x2	M48x2
$\varnothing D3$	60	70	82
G	72	84	96
L1	188	232	265
L2	144	168	192
L3	40	63,5	73

LA FORNITURA COMPRENDE:  
n° 1 FORCELLA  
n° 1 PERNO  
n° 2 SEGER  
THE SUPPLY INCLUDES:  
n° 1 FORK  
n° 1 PIN  
n° 2 RETAINING RING

MATERIALE: ACCIAIO ZINCATO  
MATERIAL: ZINC COATED STEEL

## SNODO SFERICO FILETTO INTERNO

SSFI

### ROD EYE (INTERNAL THREAD)

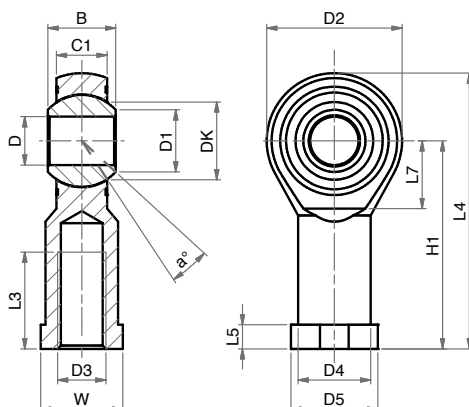

MATERIALE: CORPO IN ACCIAIO ZINCATO  
SNODO IN ACCIAIO,  
BRONZO E PTFE  
MATERIAL: BODY IN ZINC COATED STEEL  
EYE IN STEEL, BRONZE  
AND PTFE

#### DIMENSIONI - DIMENSIONS

COD.	SSFI36x2	SSFI42x2	SSFI48x2
$\alpha^\circ$	16	16	14
B	43	49	60
C1	28	33	45
D1	37,7	45,1	56,6
D2	80	91	117
D3	M36x2	M42x2	M48x2
D4	46	53	65
D5	58	65	75
DK	57,15	66,6	82,5
$\varnothing D$	35	40	50
H1	125	142	162
L3	56	60	65
L4	165	187	218
L5	17	19	23
L7	41	45	58
W	50	55	65

## SNODO SFERICO FILETTO ESTERNO

SSFE

### ROD EYE (EXTERNAL THREAD)

SERIE

K

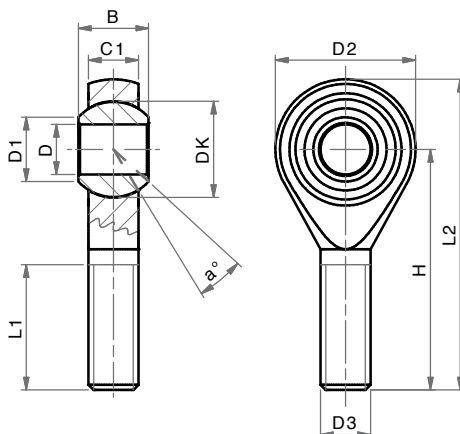

MATERIALE: CORPO IN ACCIAIO ZINCATO  
SNODO IN ACCIAIO,  
BRONZO E PTFE  
MATERIAL: BODY IN ZINC COATED STEEL  
EYE IN STEEL, BRONZE  
AND PTFE

#### DIMENSIONI - DIMENSIONS

COD.	SSFE20x2,5
$\alpha^\circ$	14
B	25
C1	19
D1	24,3
D2	50
D3	M20
DK	34,52
$\varnothing D$	20
H	78
L1	45
L2	103

## SENSORI MAGNETICI

### MAGNETIC SENSORS

CARATTERISTICHE - CHARACTERISTICS					
CODICE - CODE		36.SEN06 36.SEN06.L6	36.SEN07	36.SEN08	36.SEN09 36.SEN09.L6 36.SEN09.L10
TIPO - TYPE		REED	REED	ELETTRONICO ELECTRONIC	ELETTRONICO ELECTRONIC
Modello elettrico - Electrical design		AC/DC PNP/NPN	AC/DC PNP/NPN	DC PNP	DC PNP
Funzione dell'uscita - Output		NO	NO	NO	NO
Tensione di esercizio - Operating voltage	[V]	5...120 AC/DC	5...60 DC / 5...50 AC	10...30 DC	10...30 DC
Capacità di corrente - Current rating	[mA]	100*	100*	100	100
Sensibilità di reazione - Magnetic sensitivity	[mT]	2,1	2,1	2,8	2,8
Velocità di passaggio - Travel speed	[m/s]	> 10	> 10	> 10	> 10
Protezione da cortocircuito - Short-circuit proof		no	no	si - yes	si - yes
Protetto da inversione di polarità Reverse polarity protection		si - yes	si - yes	si - yes	si - yes
Resistente a sovraccarico - Overload protection		no	no	si - yes	si - yes
Caduta di tensione - Voltage drop	[V]	< 5	< 5	< 2,5	< 2,5
Isteresi - Hysteresis		1	1	< 1,5	< 1,5
Riproducibilità - Repeatability	[mm]	± 0,2	± 0,2	< 0,2	< 0,2
Corrente assorbita - Current consumption	[mA]	-	-	< 10	< 10
Tempo di commutazione - Make time	[ms]	≤ 0,6	≤ 0,6	-	-
Tempo di riapertura - Fall time	[ms]	≤ 0,1	≤ 0,1	-	-
Potenza max - Switching power max	[W]	10	10	-	-
Cicli di commutazione con connessione a PLC Switching cycles when connected to PLC	[mln]	≤ 40	≤ 40	-	-
Frequenza di commutazione - Switching frequency	[Hz]	1.000	1.000	> 10.000	> 10.000
Temperatura ambiente - Ambient temperature	[°C]	-25...70	-25...70	-25...80	-25...80
Grado/Classe di protezione - Protection		IP67, II	IP67, II	IP67, III	IP67, III
Materiale involucro - Housing material		PA (poliammide - polyamide)			
Materiale eccentrico di fissaggio - Fastening clamp		inox - stainless steel			
Indicazione della funzione Stato di commutazione Function display Switching status	LED	giallo - yellow			
Collegamento - Connection		cavo PUR - PUR cable 2x0,14 mm <sup>2</sup> 2 m (.L6 = 6 m)	cavo PUR - PUR cable connettore M8- M8 connector 0,3 m	cavo PUR - PUR cable connettore M8- M8 connector 0,3 m	cavo PUR - PUR cable 3x0,14 mm <sup>2</sup> 2 m (.L6 = 6 m   .L10 = 10 m)
Peso - Weight	[g]	31,3 69	12	12,1	27,4 73,5 122,4

SERIE  
**K**

Accessori inclusi: Segnaposto in gomma, fascetta fermacavo - Accessories included: Rubber placeholder, cable clip

\*: necessario circuito di protezione esterno per carico induttivo (valvola, relè, ecc...). - External protective circuit for inductive load (valve, contactor, etc...) necessary.

REED: nessuna funzione LED in caso di inversione di polarità nel funzionamento DC. - No LED function in case of polarity reversal in DC operation.

**CONTATTO REED (2 FILI)**

36.SEN06

36.SEN06.L6

**REED CONTACT (2 WIRES)**

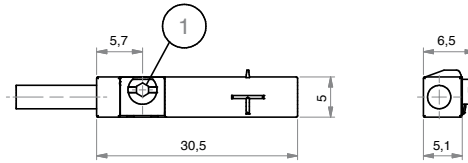

1= ECCENTRICO DI FISSAGGIO - FASTENING CLAMP

**CABLAGGIO - WIRING**

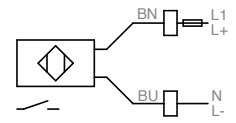

BN= MARRONE - BROWN  
BU= BLU - BLUE

**CONTATTO REED (CONNETTORE M8)**

36.SEN07

**REED CONTACT (M8 CONNECTOR)**

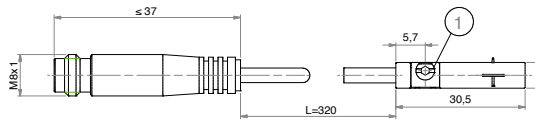

1= ECCENTRICO DI FISSAGGIO - FASTENING CLAMP

**CABLAGGIO - WIRING**

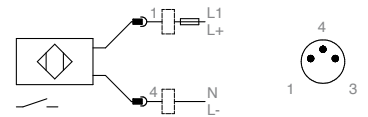

BN= MARRONE - BROWN  
BU= BLU - BLUE

SERIE

**K**

**CONTATTO PNP (CONNETTORE M8)**

36.SEN08

**PNP CONTACT (M8 CONNECTOR)**

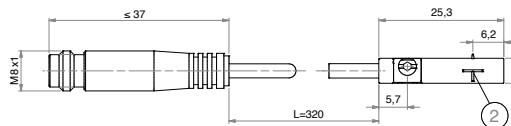

1= ECCENTRICO DI FISSAGGIO FASTENING CLAMP  
2= SUPERFICIE ATTIVA SENSING FACE

**CABLAGGIO - WIRING**

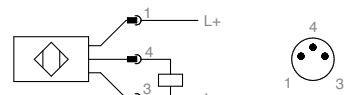

BN= MARRONE - BROWN  
BU= BLU - BLUE

**CONTATTO PNP (3 FILI)**

36.SEN09

36.SEN09.L6

36.SEN09.L10

**PNP CONTACT (3 WIRES)**

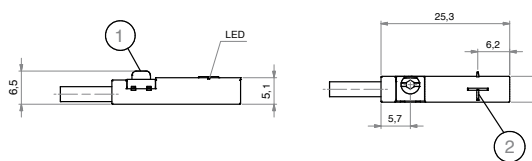

1= ECCENTRICO DI FISSAGGIO - FASTENING CLAMP  
2= SUPERFICIE ATTIVA - SENSING FACE

**CABLAGGIO - WIRING**

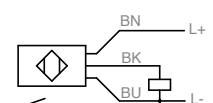

BK= NERO - BLACK  
BN= MARRONE - BROWN  
BU= BLU - BLUE

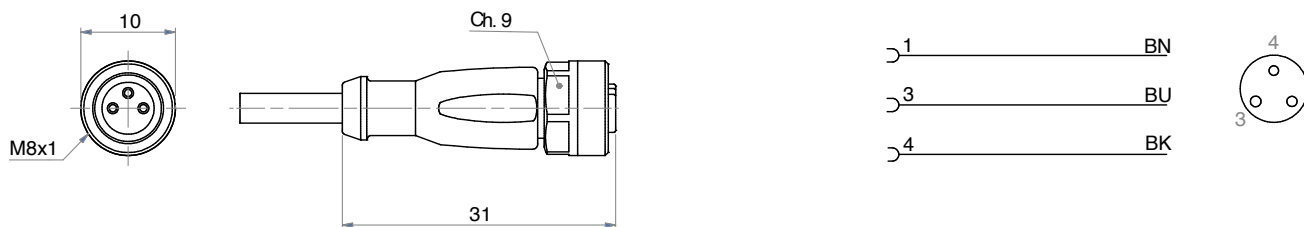
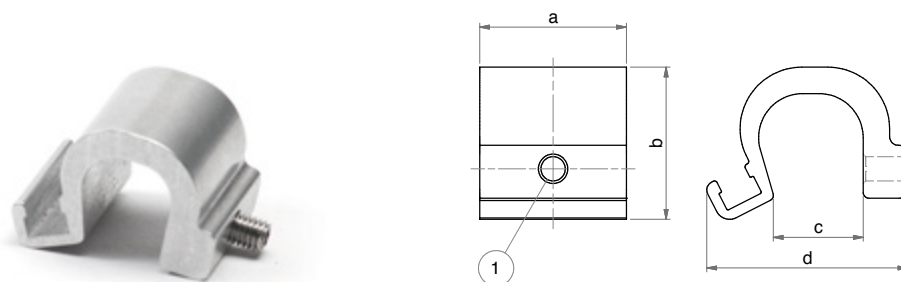

**CAVO PROLUNGA (CONNETTORE M8)**
**EXTENSION CABLE (M8 CONNECTOR)**

**ADATTATORE PER TIRANTE**
**SENSOR MOUNTING FOR TIE ROD**

1 = VITE DI FISSAGGIO FIXING SCREW (2,5)

**DIMENSIONI - DIMENSIONS**

COD.		36.TIR11	36.TIR15	36.TIR20
<b>Gamma di morsetti - Clamping range</b>	[mm]	5÷11	9÷15	14÷20
<b>a</b>		25	25	25
<b>b</b>		22,8	25,9	31,1
<b>c</b>		11,3	15,3	20,3
<b>d</b>		30,2	34,2	39,6
<b>Materiali involucro - Housing materials</b>		alluminio - aluminium; vite-screw: inox-stainless steel		

**SENSORI MAGNETICI ATEX**
**ATEX MAGNETIC SENSORS**

<b>CARATTERISTICHE - CHARACTERISTICS</b>		<b>36.SEN32A.L6</b>	<b>36.SEN33A</b>
<b>TIPO - TYPE</b>		<b>ELETTRONICO - ELECTRONIC</b>	<b>ELETTRONICO - ELECTRONIC</b>
<b>Modello elettrico - Electrical design</b>		DC PNP	DC PNP
<b>Funzione dell'uscita - Output</b>		NO	NO
<b>Tensione di esercizio - Operating voltage</b>	[V]	10...30 DC	10...30 DC
<b>Capacità di corrente - Current rating</b>	[mA]	100	100
<b>Sensibilità di reazione - Magnetic sensitivity</b>	[mT]	2	2,8
<b>Velocità di passaggio - Travel speed</b>	[m/s]	> 10	> 10
<b>Protezione da cortocircuito - Short-circuit proof</b>		si - yes	si - yes
<b>Protetto da inversione di polarità - Reverse polarity protection</b>		si - yes	si - yes
<b>Resistente a sovraccarico - Overload protection</b>		si - yes	si - yes
<b>Caduta di tensione - Voltage drop</b>	[V]	< 2,5	< 2,5
<b>Isteresi - Hysteresis</b>		1	< 1,5
<b>Riproducibilità - Repeatability</b>	[mm]	< 0,2	< 0,2
<b>Corrente assorbita - Current consumption</b>	[mA]	< 10	< 10
<b>Ritardo alla disponibilità - Power-on delay time</b>	[ms]	< 30	< 30
<b>Frequenza di commutazione - Switching frequency</b>	[Hz]	6.000	10.000
<b>Temperatura ambiente - Ambient temperature</b>	[°C]	-20...60	-25...60
<b>Grado/Classe di protezione - Protection</b>		IP 65/IP 67	IP 65/IP 67
<b>Contrassegno - Marking of the unit</b>		II 3D Ex tc IIIC T125°C Dc X II 3G Ex nA IIC T4 Gc X	II 3D Ex tc IIIC T125°C Dc X
<b>Materiale involucro - Housing material</b>		PA (poliammide-polyamide)	PA (poliammide-polyamide)
<b>Materiale eccentrico di fissaggio - Fastening clamp</b>		inox - stainless steel	inox - stainless steel
<b>Indicazione della funzione Stato di commutazione Function display Switching status</b>	LED	giallo - yellow	giallo - yellow
<b>Collegamento - Connection</b>		cavo PVC - PVC cable 3x0,14 mm <sup>2</sup>	cavo PVC - PVC cable connettore M12 - M12 connector
<b>Lunghezza cavo - Cable length</b>		6 m	0,3 m
<b>Peso - Weight</b>	[g]	103,3	52,4

Accessori inclusi - Accessories included: Segnaposto in gomma, fascetta fermacavo - Rubber placeholder, cable clip

## CONTATTO PNP (3 FILI)



36.SEN32A.L6

### PNP CONTACT (3 WIRES)



1= ECCENTRICO DI FISSAGGIO - FASTENING CLAMP  
2= SUPERFICIE ATTIVA - SENSING FACE

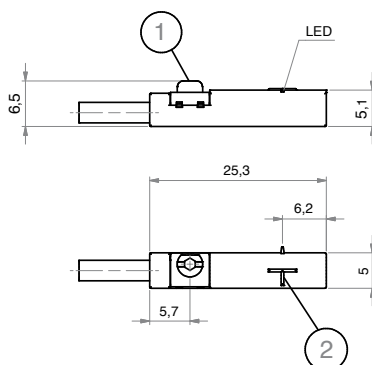

CABLAGGIO - WIRING

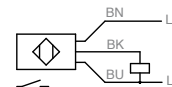

BK= NERO - BLACK  
BN= MARRONE - BROWN  
BU= BLU - BLUE

## CONTATTO PNP (CONNETTORE M12)



36.SEN33A

### PNP CONTACT (M12 CONNECTOR)



1= ECCENTRICO DI FISSAGGIO - FASTENING CLAMP  
2= SUPERFICIE ATTIVA - SENSING FACE

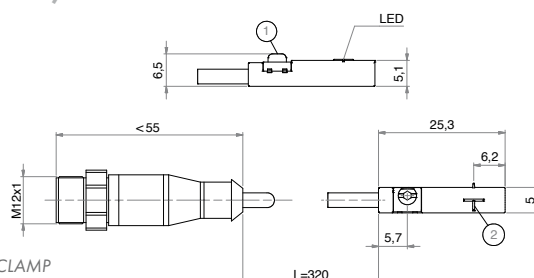

CABLAGGIO - WIRING

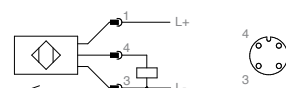

BK= NERO - BLACK  
BN= MARRONE - BROWN  
BU= BLU - BLUE

## CAVO PROLUNGA (CONNETTORE M12)



36.CAVA

### EXTENSION CABLE (M12 CONNECTOR)

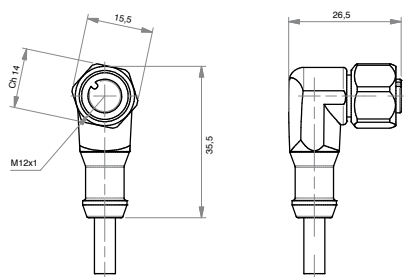

CABLAGGIO - WIRING

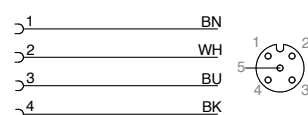

BK= NERO - BLACK  
BN= MARRONE - BROWN

BU= BLU - BLUE  
WH= BIANCO - WHITE

## DIMENSIONI - DIMENSIONS

		36.CAV5A.M12	36.CAV10A.M12
<b>Modello elettrico - Electrical design</b>		AC/DC	AC/DC
<b>Tensione di esercizio - Operating voltage</b>	[V]	60 AC / 60 DC	60 AC / 60 DC
<b>Capacità di corrente - Current rating</b>	[A]	2	2
<b>Modello - Design</b>		ad angolo - angled	ad angolo - angled
<b>Temperatura ambiente - Ambient temperature</b>	[°C]	-20...60	-20...60
<b>Grado/Classe di protezione - Protection</b>		IP67/IP68 - IP69K fuori dalla zona esplosiva - outside hazardous areas	
<b>Contrassegno - Marking of the unit</b>		II 3G Ex nA IIC Gc - II 2D Ex tb IIIC Db IP65/IP67	
<b>Materiale corpo - Body material: Involucro - Housing</b>		TPU arancione - orange TPU	TPU arancione - orange TPU
<b>Guarnizione - Sealing</b>		viton	viton
<b>Materiale dado - Nut material</b>		inox - stainless steel (1.4404 / 316L)	inox - stainless steel (1.4404 / 316L)
<b>Coppia di serraggio per nodo nocciolo - Tightening torque for knurled nut</b>	[Nm]	0,2...1,5	0,2...1,5
<b>Collegamento - Connection</b>		cavo PUR - PUR cable / 5 m; 4 x 0,34 mm <sup>2</sup> (42 x Ø 0,1 mm); Ø 4,9 mm; senza alogeno - alogen free	cavo PUR - PUR cable / 10 m; 4 x 0,34 mm <sup>2</sup> (42 x Ø 0,1 mm); Ø 4,9 mm; senza alogeno - alogen free
<b>Colore della guaina - Sheath colour</b>		nero - black	nero - black

