

SERIE

D

CILINDRI SENZA STELO
RODLESS CYLINDERS

ARTEC[®]
PNEUMATIC COMPONENTS

CARATTERISTICHE TECNICHE - TECHNICAL CHARACTERISTICS

Pressione di esercizio <i>Working pressure</i>	0,5 ÷ 8 bar
Temperatura di esercizio <i>Working temperature</i>	0 ÷ +80°C (-10°C con aria secca - <i>with dry air</i>)
Velocità massima <i>Maximum speed</i>	1 m/s
Versioni - Versions	doppio effetto - <i>double acting</i>
Alesaggi - Bores	∅ 16 - 25 - 32 - 40 - 50 - 63
Corse - Strokes	vedere tabelle corse standard - <i>see standard stroke tables</i>
Fluido - Fluid	aria compressa filtrata, non lubrificata - <i>compressed filtered, non lubricated air</i>

CARATTERISTICHE COSTRUTTIVE - CONSTRUCTIVE CHARACTERISTICS

Testate - Covers	alluminio anodizzato - <i>anodized aluminium</i>
Tubo - Tube	alluminio anodizzato - <i>anodized aluminium</i>
Carro - Carriage	alluminio anodizzato - <i>anodized aluminium</i>
Bandella - Band	acciaio inox - <i>stainless steel</i>
Guarnizioni - Seals	NBR
Pistone - Piston	alluminio pressofuso - <i>die cast aluminium</i>
Viti - Screws	acciaio zincato - <i>zinc coated steel</i>

CHIAVE DI CODIFICA

KEY CODE

D D M 0 5 0 . 1 0 0 0 . G S . C 1	
ALESAGGIO - BORE (∅) 016-025-032-040-050-063	CORSA - STROKE (mm) vedere tabelle corse std <i>see std stroke tables</i>
VERSIONE - VERSION M magnetico <i>magnetic</i>	GUARNIZIONI - SEALS guarnizioni standard <i>standard seals</i> GS tutte le guarnizioni per alte temperature <i>all seals for high temperature</i> VA
VERSIONE - VERSION D doppio effetto <i>double acting</i>	CARRO - CARRIAGE C0 stretto <i>narrow</i> C1 standard <i>standard</i> C2 guidato <i>with guide</i> C3 guidato con cuscinetti a ricircolo di sfere <i>with guide and recirculating ball bearings</i> C4 guidato con guida prismatica <i>with guide and prismatic guide</i> C5 standard guidato <i>standard with guide</i>
SERIE - SERIES D cilindri senza stelo <i>rodless cylinders</i>	OPZIONE - OPTION 5 con viti in acciaio inox <i>with stainless steel screws</i>

ESECUZIONI A RICHIESTA - ON REQUEST

Corse fino a 5700 mm - *Strokes up to 5700 mm*

DIAGRAMMA AMMORTIZZO

CUSHIONING DIAGRAM

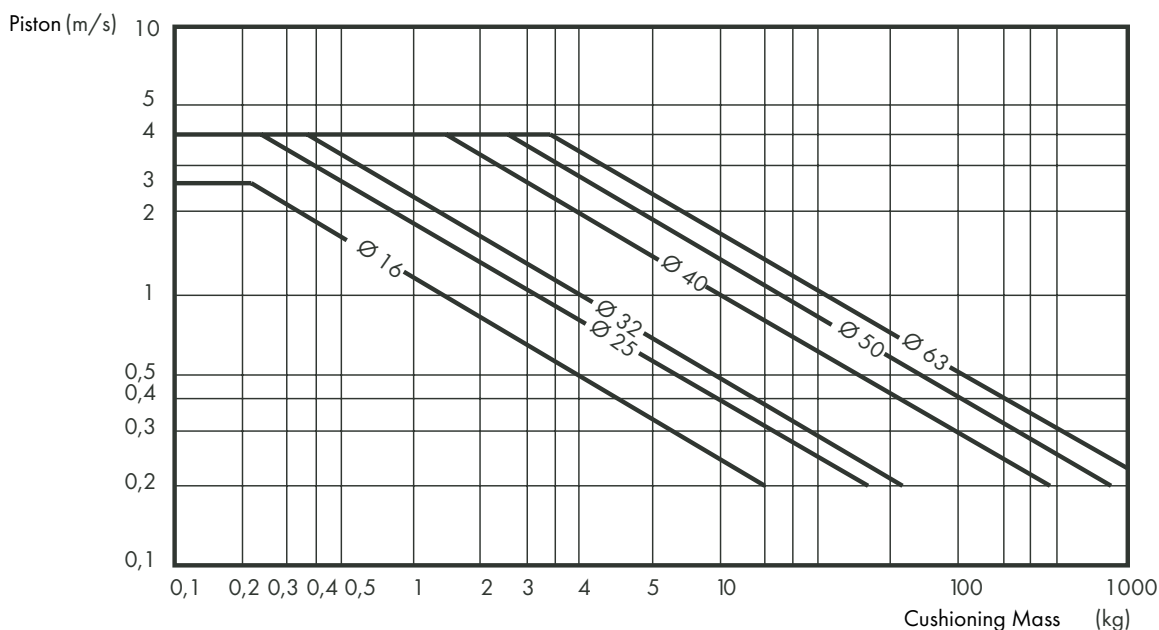

!!! Se i valori sopra indicati vengono superati, sono necessari ammortizzatori aggiuntivi; Velocità ≥ 1 m/s, si consigliano guarnizioni per alte temperature; La durata massima delle guarnizioni si ottiene con velocità < 1 m/s.
 !!! If the limits above are exceeded additional shock absorbers are necessary; With speeds ≥ 1 m/s high temperature seals are recommended; The Maximum seals lifetime will be obtained with speed < 1 m/s.

DIAGRAMMA TEORICO CARICO AMMISSIBILE

C0

THEORETICAL ALLOWABLE LOAD

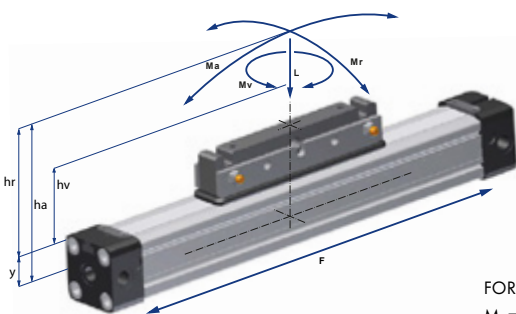

FORMULA / FORMULAS

$$M_a = F \cdot h_a$$

$$M_r = F \cdot h_r$$

$$M_v = F \cdot h_v$$

!!! I valori indicati in tabella sono validi per una velocità massima di 0,45 m/sec e una pressione massima di 6 bar. Nel caso di valori di carico non ben definiti ridurre i valori in tabella del 10-20%.

!!! The values in the chart are valid for a maximum speed of 0,45 m/sec and for a maximum pressure of 6 bar. In case of undefinable load values, values in the chart must be reduced by 10-20%.

DIMENSIONI - DIMENSIONS

Ø	Y	Effect force (N)	Cushioning	Max allowed load	Max allowed bending moments (Nm)		Max allowed torque
		(6 bar)	(mm)	(N)	Ma axial	Mr radial	(N)
		F	S	L			Mv zentral
16	9	110	15	120	4	0,3	0,3
25	14	250	21	300	15	1	3
32	18	420	26	450	30	2	4,5
40	22	640	32	750	60	4	8

SERIE

D

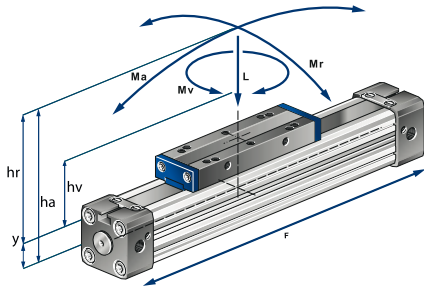
DIAGRAMMA TEORICO CARICO AMMISSIBILE
THEORETICAL ALLOWABLE LOAD

DIMENSIONI - DIMENSIONS

Ø	Y	Effect force (N) (6 bar)	Cushioning (mm)	Max allowed load (N)	Max allowed bending moments (Nm)		Max allowed torque (N)
					Ma axial	Mr radial	
16	9	110	15	120	4	0,3	0,5
25	14	250	21	300	15	1	3
32	18	420	26	450	30	2	4,5
40	22	640	32	750	60	4	8
50	28	1000	32	1200	115	7	15
63	36	1550	40	1650	200	8	24

FORMULA / FORMULAS

$$M_a = F \cdot h_a$$

$$M_r = F \cdot h_r$$

$$M_v = F \cdot h_v$$

!!! I valori indicati in tabella sono validi per una velocità massima di 0,45 m/sec e una pressione massima di 6 bar. Nel caso di valori di carico non ben definiti ridurre i valori in tabella del 10-20%.
 !!! The values in the chart are valid for a maximum speed of 0,45 m/sec and for a maximum pressure of 6 bar. In case of undefinable load values, values in the chart must be reduced by 10-20%.

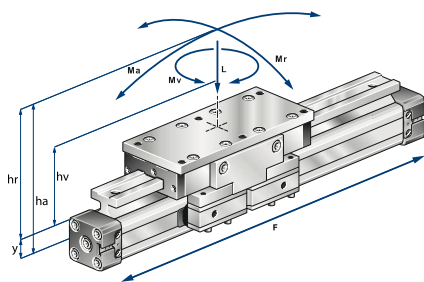
DIAGRAMMA TEORICO CARICO AMMISSIBILE
THEORETICAL ALLOWABLE LOAD

DIMENSIONI - DIMENSIONS

Ø	F (N) 6 bar	L max (N)	Mr max (Nm)	Ma max (Nm)	Mv max (Nm)
16	110	350	4	6	6
25	250	1000	14	40	40
32	420	2000	24	68	68
40	640	2800	37	103	103

FORMULA / FORMULAS

$$M_a = F \cdot h_a$$

$$M_r = F \cdot h_r$$

$$M_v = F \cdot h_v$$

!!! I valori indicati in tabella sono validi per una velocità massima di 0,2 m/sec e una pressione massima di 6 bar. Nel caso di valori di carico non ben definiti ridurre i valori in tabella del 10-20%.
 !!! The values in the chart are valid for a maximum speed of 0,2 m/sec and for a maximum pressure of 6 bar. In case of undefinable load values, values in the chart must be reduced by 10-20%.

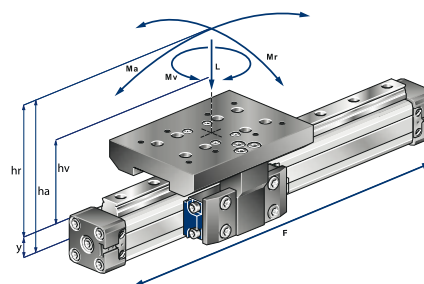
DIAGRAMMA TEORICO CARICO AMMISSIBILE
THEORETICAL ALLOWABLE LOAD

FORMULA / FORMULAS

$$M_a = F \cdot h_a$$

$$M_r = F \cdot h_r$$

$$M_v = F \cdot h_v$$

!!! I valori indicati in tabella sono validi per una velocità massima di 0,2 m/sec e una pressione massima di 6 bar. Nel caso di valori di carico non ben definiti ridurre i valori in tabella del 10-20%.
 !!! The values in the chart are valid for a maximum speed of 0,2 m/sec and for a maximum pressure of 6 bar. In case of undefinable load values, values in the chart must be reduced by 10-20%.

DIMENSIONI - DIMENSIONS

Characteristics	16	25	32	40	50	63
effect force (6bar) (N)	110	250	420	640	1000	1550
cushioning (mm)	15	21	26	32	32	40
A (mm)	35	53	64	69	90	102
B (mm)	19	26	29,7	29,7	40	38,5
C/D/E/F (mm)	Dimensions according design					
G (mm)	30,3	38	55	54,5	65	75
H (mm)	31,5	40	57,5	57,5	68,5	85
I (mm)	31,5	40	57,5	57,5	65	85
Load forces max L (N)	500	1500	3000	3000	4000	4000
Moment Forces max La-Lr-Lv (N)	500	1500	3000	3000	4000	4000
Axial moments max Ma (Nm)	8	40	58	58	200	200
Radial moments max Mr (Nm)	4	15	23	23	70	70
Torsion moments max Mv (Nm)	8	40	58	58	200	200

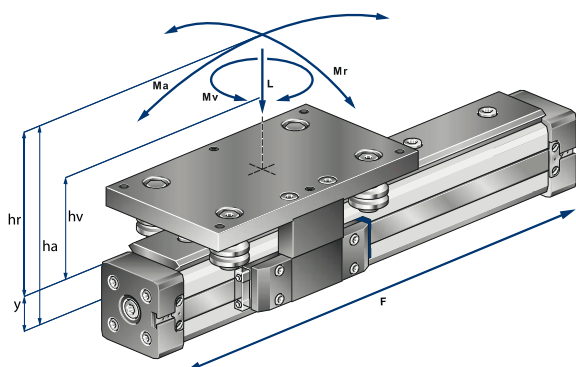
DIAGRAMMA TEORICO CARICO AMMISSIBILE
THEORETICAL ALLOWABLE TORQUE

FORMULA / FORMULAS

$$M_a = F \cdot h_a$$

$$M_r = F \cdot h_r$$

$$M_v = F \cdot h_v$$

!!! I valori indicati in tabella sono validi per una velocità massima di 0,2 m/sec e una pressione massima di 6 bar. Nel caso di valori di carico non ben definiti ridurre i valori in tabella del 10-20%.

!!! The values in the chart are valid for a maximum speed of 0,2 m/sec and for a maximum pressure of 6 bar. In case of undefinable load values, values in the chart must be reduced by 10-20%.

DIMENSIONI - DIMENSIONS

PLR - Movements	25	32	40	50
effect force (6bar) (N)	250	420	640	1000
A (mm)	53	64	72,5	88,5
B (mm)	20,5	26	28	28
C/D/E/F (mm)	Dimensions according design			
G (mm)	38	55,5	54,5	58,5
H (mm)	40	58	67,5	67,5
I (mm)	40	58	67,5	67,5
Load forces max L (N)	1400	3100	3100	3100
Moment forces max La, Lr, Lv (N)	1400	3100	3100	3100
Axial moments max Ma (Nm)	50	165	250	250
Radial moments max Mr (Nm)	14	65	90	90
Torsion moments max Mv (Nm)	50	165	250	250

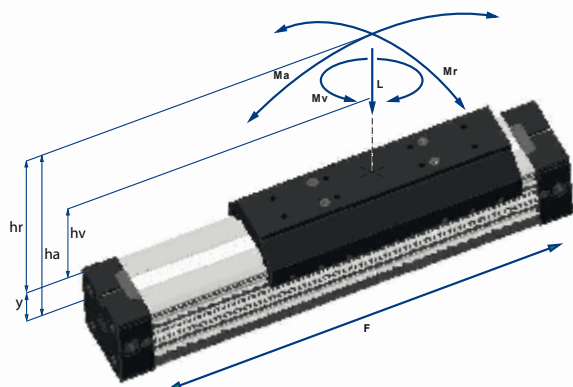
DIAGRAMMA TEORICO CARICO AMMISSIBILE
THEORETICAL ALLOWABLE LOAD

FORMULA / FORMULAS

$$M_a = F \cdot h_a$$

$$M_r = F \cdot h_r$$

$$M_v = F \cdot h_v$$

!!! I valori indicati in tabella sono validi per una velocità massima di 0,2 m/sec e una pressione massima di 6 bar. Nel caso di valori di carico non ben definiti ridurre i valori in tabella del 10-20%.

!!! The values in the chart are valid for a maximum speed of 0,2 m/sec and for a maximum pressure of 6 bar. In case of undefinable load values, values in the chart must be reduced by 10-20%.

DIMENSIONI - DIMENSIONS

Ø	Y	Effect force (N)	Cushioning	Max allowed load	Max allowed bending moments (Nm)		Max allowed torque
		(6 bar)	(mm)	(N)	Ma axial	Mr radial	(N)
		F	S	L			Mv zentral
32	18	420	26	495	39	15	39
40	22	640	32	825	99	35	99
50	28	1000	32	1320	170	58	170
63	36	1550	40	1815	315	105	317

CILINDRO SENZA STELO CON CARRO STRETTO

RODLESS CYLINDER WITH NARROW CARRIAGE

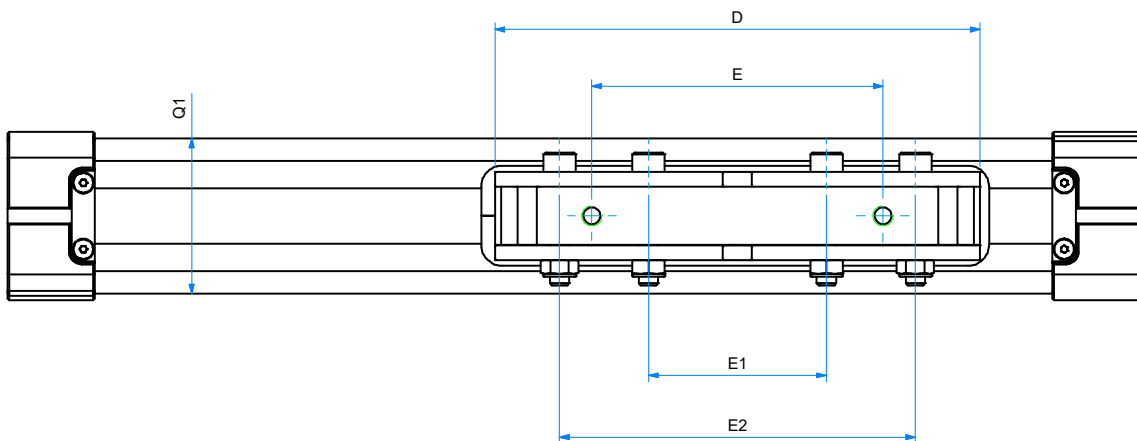
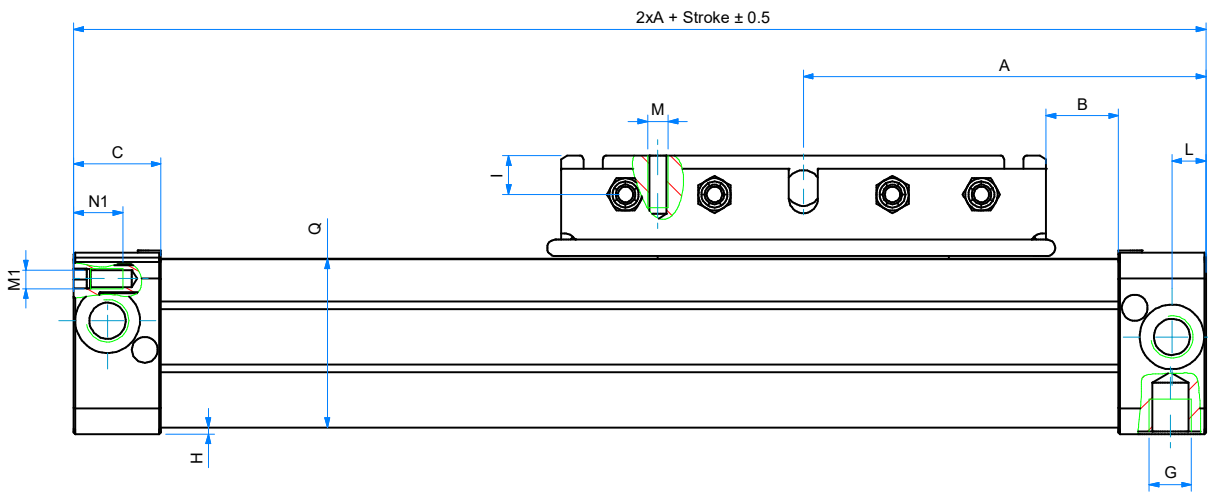
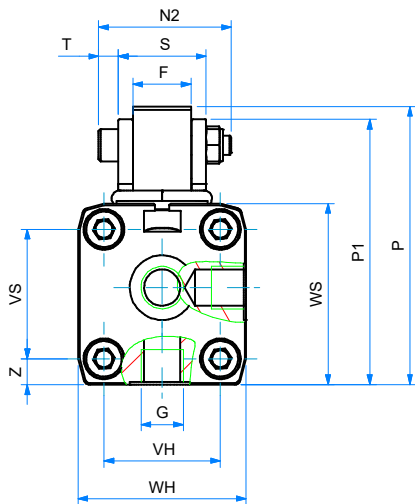

SERIE

D

CILINDRO SENZA STELO CON CARRO STRETTO
RODLESS CYLINDER WITH NARROW CARRIAGE

DIMENSIONI - DIMENSIONS				
Ø	16	25	32	40
A+	65	100	125	150
B	12	17	23	45
C	15	23	27	30
D	76	120	150	150
E	48	80	90	90
E1	32	50	55	55
F	10	15	18	18
G	M5	G1/8	G1/4	G1/4
I	6	13	12	12
L	5,5	8,5	10,5	15
M	M4	M5	M6	M6
M1	M3	M5	M6	M6
N1	7	10	14	17
N2	27	35	41	41
P	43,5	66	86	96
P1	42,3	58	82	92
QxQ1	24,5x25	36x36	52x51	58,5x59
E2	64	100	110	110
H	1	2	2	7
S	18	23	27	28
T	4	5	6	6
VH	18	27	36	54
WH	27	40	52	72
VS	18	27	40	54
WS	27	40	56	69
Z	4,5	6,5	8	9

+ = lunghezza corsa - stroke length

Ø	CORSE STANDARD - STANDARD STROKES
016	100 - 200 - 300 - 400 - 500 - 600 - 700 - 800 - 900 - 1000 - 1100 - 1200 - 1300 - 1400 - 1500 - 1600 - 1700 - 1800 - 1900 - 2000
025	100 - 200 - 300 - 400 - 500 - 600 - 700 - 800 - 900 - 1000 - 1100 - 1200 - 1300 - 1400 - 1500 - 1600 - 1700 - 1800 - 1900 - 2000
032	100 - 200 - 300 - 400 - 500 - 600 - 700 - 800 - 900 - 1000 - 1100 - 1200 - 1300 - 1400 - 1500 - 1600 - 1700 - 1800 - 1900 - 2000
040	100 - 200 - 300 - 400 - 500 - 600 - 700 - 800 - 900 - 1000 - 1100 - 1200 - 1300 - 1400 - 1500 - 1600 - 1700 - 1800 - 1900 - 2000
050	100 - 200 - 300 - 400 - 500 - 600 - 700 - 800 - 900 - 1000 - 1100 - 1200 - 1300 - 1400 - 1500 - 1600 - 1700 - 1800 - 1900 - 2000
063	100 - 200 - 300 - 400 - 500 - 600 - 700 - 800 - 900 - 1000 - 1100 - 1200 - 1300 - 1400 - 1500 - 1600 - 1700 - 1800 - 1900 - 2000

CILINDRO SENZA STELO CON CARRO STANDARD

RODLESS CYLINDER WITH STANDARD CARRIAGE

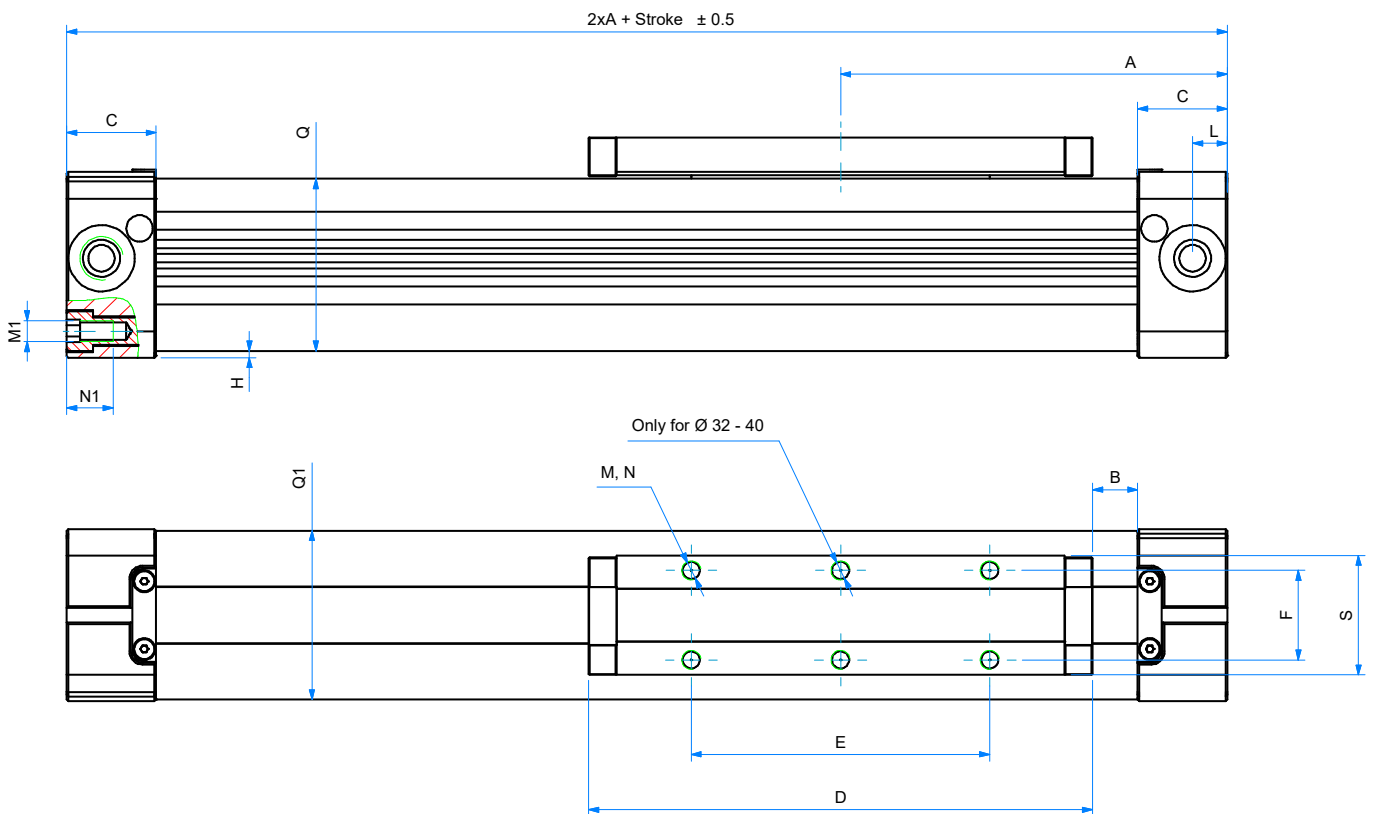
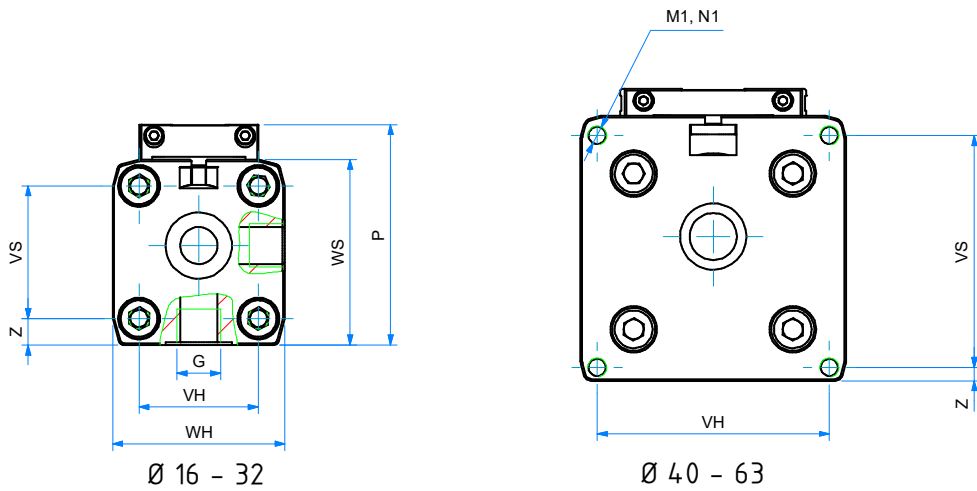

SERIE

D

CILINDRO SENZA STELO CON CARRO STANDARD
RODLESS CYLINDER WITH STANDARD CARRIAGE

DIMENSIONI - DIMENSIONS							
Ø	16	25	32	40	50	63	
A+	65	100	125	150	175	215	
B	15,5	21	22	44	42	47,5	
C	15	23	27	30	33	50	
D	69	111	152	152	200	235	
E	36	65	90	90	110	155	
F	16,5	25	27	27	27	36	
G	M5	G1/8	G1/4	G1/4	G1/4	G3/8	
H	1	2	2	6,75	0,5	1,5	
L	5,5	8,5	10,5	15	11,7	25	
M	M4	M5	M6	M6	M6	M8	
M1	M3	M5	M6	M6	M6	M8	
N	7	10	7	10	6	15	
N1	7	12	14	17	18	18	
P	36,5	52,5	66,5	80	88	123	
QxQ1	24,5x25	36x36	52x51	58,5x59	77x78	102x102	
S	22	33	36	36,4	56	50	
VS	18	27	40	54	70	78	
VH	18	27	36	54	70	78	
WS	27	40	56	69	80	106	
WH	27	40	52	72	80	106	
Z	4,5	6,5	8	9	4	14,5	

+ = lunghezza corsa - stroke length

Ø	CORSE STANDARD - STANDARD STROKES
016	100 - 200 - 300 - 400 - 500 - 600 - 700 - 800 - 900 - 1000 - 1100 - 1200 - 1300 - 1400 - 1500 - 1600 - 1700 - 1800 - 1900 - 2000
025	100 - 200 - 300 - 400 - 500 - 600 - 700 - 800 - 900 - 1000 - 1100 - 1200 - 1300 - 1400 - 1500 - 1600 - 1700 - 1800 - 1900 - 2000
032	100 - 200 - 300 - 400 - 500 - 600 - 700 - 800 - 900 - 1000 - 1100 - 1200 - 1300 - 1400 - 1500 - 1600 - 1700 - 1800 - 1900 - 2000
040	100 - 200 - 300 - 400 - 500 - 600 - 700 - 800 - 900 - 1000 - 1100 - 1200 - 1300 - 1400 - 1500 - 1600 - 1700 - 1800 - 1900 - 2000
050	100 - 200 - 300 - 400 - 500 - 600 - 700 - 800 - 900 - 1000 - 1100 - 1200 - 1300 - 1400 - 1500 - 1600 - 1700 - 1800 - 1900 - 2000
063	100 - 200 - 300 - 400 - 500 - 600 - 700 - 800 - 900 - 1000 - 1100 - 1200 - 1300 - 1400 - 1500 - 1600 - 1700 - 1800 - 1900 - 2000

CILINDRO SENZA STELO CON CARRO GUIDATO

RODLESS CYLINDER WITH GUIDED CARRIAGE

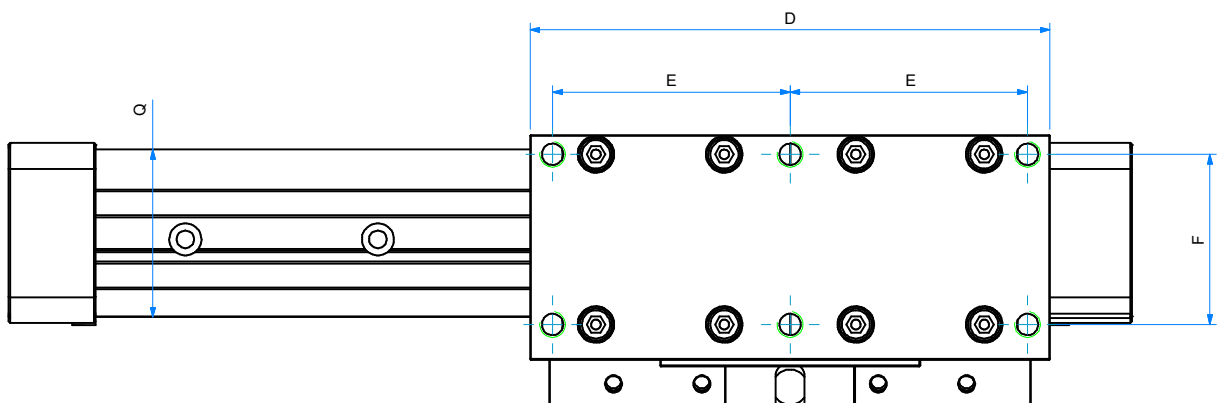
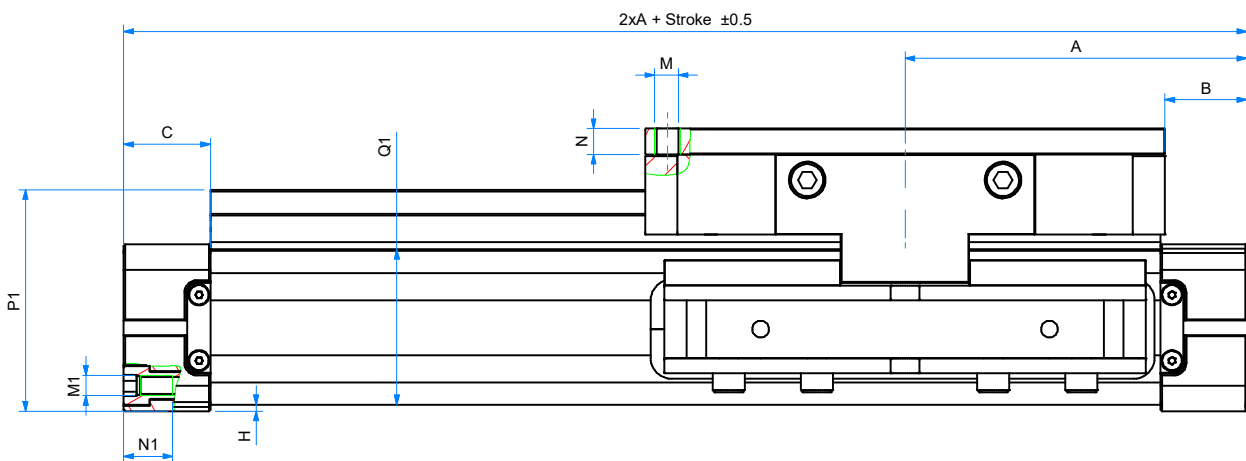
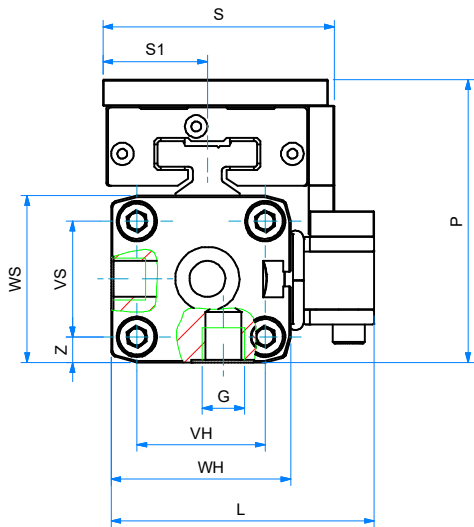

SERIE

D

CILINDRO SENZA STELO CON CARRO GUIDATO
RODLESS CYLINDER WITH GUIDED CARRIAGE

DIMENSIONI - DIMENSIONS				
Ø	016	025	032	040
A+	65	100	125	150
C	15	23	27	30
D	90	162	162	162
E	20	74	74	74
F	36	53	53	53
G	M5	G1/8	G1/4	G1/4
H	1,5	2	2	7
L	42,3	59,5	82	93
M	M4	M6	M6	M6
N	10	8	8	8
M1	M3	M5	M6	M6
N1	7	10	14	17
P	48,5	76	88,5	103
QxQ1	24,5x25	36x36	52x48	58x58
S	63	70	70	70
S1	31,5	32,5	32,5	32,5
VH	18	27	40	54
VS	18	27	36	54
WH	27	40	52	69
WS	27	40	52	72
Z	4,5	6,5	8	9

+ = lunghezza corsa - stroke length

Ø	CORSE STANDARD - STANDARD STROKES
016	100 - 200 - 300 - 400 - 500 - 600 - 700 - 800 - 900 - 1000 - 1100 - 1200 - 1300 - 1400 - 1500 - 1600 - 1700 - 1800 - 1900 - 2000
025	100 - 200 - 300 - 400 - 500 - 600 - 700 - 800 - 900 - 1000 - 1100 - 1200 - 1300 - 1400 - 1500 - 1600 - 1700 - 1800 - 1900 - 2000
032	100 - 200 - 300 - 400 - 500 - 600 - 700 - 800 - 900 - 1000 - 1100 - 1200 - 1300 - 1400 - 1500 - 1600 - 1700 - 1800 - 1900 - 2000
040	100 - 200 - 300 - 400 - 500 - 600 - 700 - 800 - 900 - 1000 - 1100 - 1200 - 1300 - 1400 - 1500 - 1600 - 1700 - 1800 - 1900 - 2000

CILINDRO SENZA STELO CON CARRO GUIDATO E CUSCINETTI A RICIRCOLO DI SFERE

RODLESS CYLINDER WITH GUIDED CARRIAGE AND RECIRCULATING BALL BEARINGS

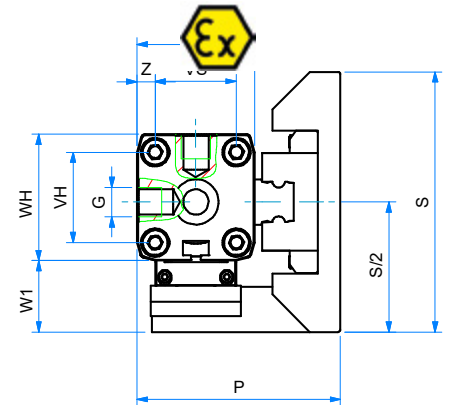
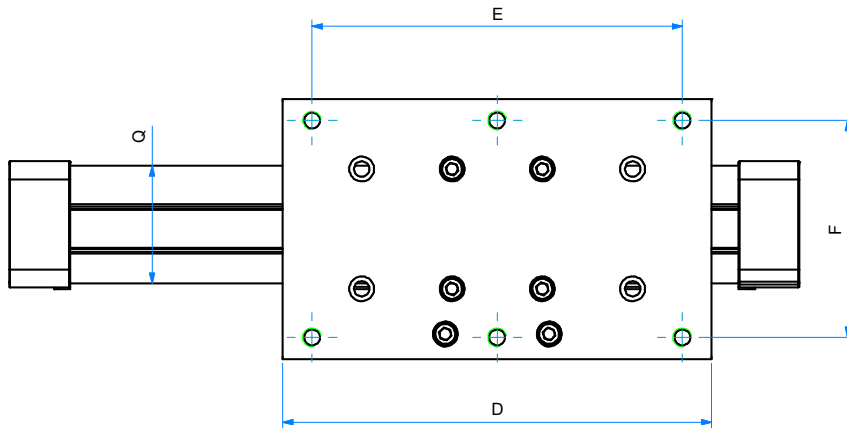
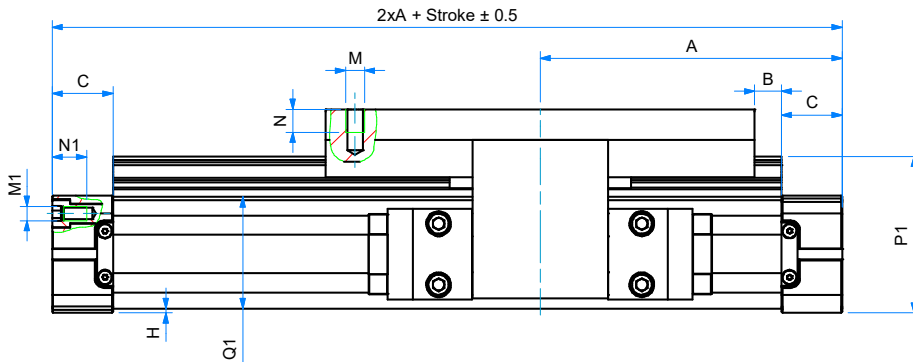
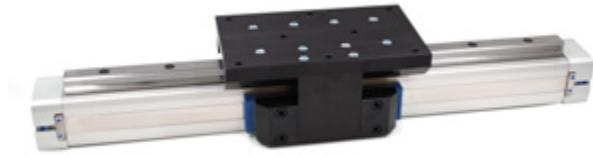

SERIE

D

ADATTATORE DECELERATORE - SHOCK ABSORBER ADAPTER

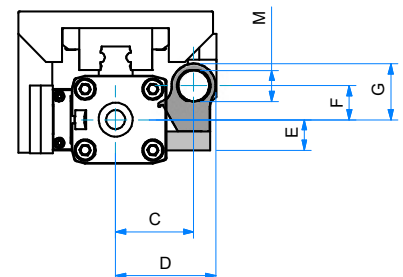
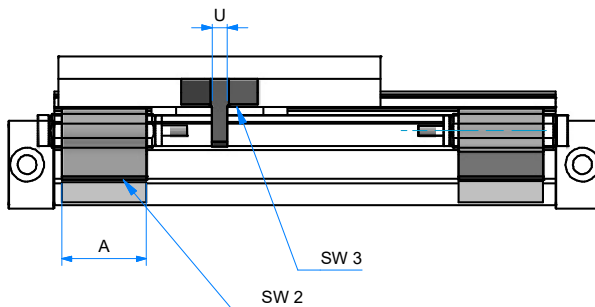

!!! Deceleratore non fornito
!!! Shock absorber adapter non supplied

CILINDRO SENZA STELO CON CARRO GUIDATO E CUSCINETTI A RICIRCOLO DI SFERE
RODLESS CYLINDER WITH GUIDED CARRIAGE AND RECIRCULATING BALL BEARINGS

DIMENSIONI - DIMENSIONS							
Ø	016	025	032	040	050	063	
A+	65	100	125	150	175	215	
B	5	4,5	3	25	34,5	57,5	
C	15	23	27	30	33	50	
D	90	145	190	190	215	215	
E	70	125	164	164	180	180	
F	36	64	96	96	110	140	
G	M5	G1/8	G1/4	G1/4	G1/4	G3/8	
H	1	2	2	7	1	2	
M	M4	M6	M8	M8	M8	M8	
N	10	12	13	18	20	20	
M1	M3	M5	M6	M6	M6	M8	
N1	7	10	14	17	18	18	
P	48,9	73	90	105	130	155	
P1	34	52,3	69,3	84,3	102,3	128,3	
QxQ1	24,5x25	36x36	48x52	58x58	77x78	102x102	
S	63	80	115	115	130	170	
S2	31,5	40	57,5	57,5	65	85	
VH	18	27	40	54	70	78	
VS	18	27	36	54	70	78	
WH	27	40	56	69	80	106	
WS	27	40	52	72	80	106	
W1	18	20	30,5	24,5	28,5	31,5	
Z	4,5	6,5	8	9	5	14	

+= lunghezza corsa - stroke length

ADATTATORE DECELERATORE - SHOCK ABSORBER ADAPTER

DIMENSIONI - DIMENSIONS						
Ø	016	025	032	040	050	
A	28	50	50	50	70	
B	43,2	81,3	95,5	94,5	102,5	
C	22,2	31,4	46,2	47,2	63	
D	29,2	41,4	59,2	60,2	79	
E	13,2	11,7	19,4	19,4	11	
F	9	15,5	20	20	31	
G	16	25,5	33	33	59	
M	M10x1	M14x1,5	M20x1,5	M20x1,5	M25x1,5	
U	8	9	9	9	-	
SW2	3	4	4	4	-	
SW3	3	4	4	4	-	

SERIE

D

Ø	CORSE STANDARD - STANDARD STROKES
016	100 - 200 - 300 - 400 - 500 - 600 - 700 - 800 - 900 - 1000 - 1100 - 1200 - 1300 - 1400 - 1500 - 1600 - 1700 - 1800 - 1900 - 2000
025	100 - 200 - 300 - 400 - 500 - 600 - 700 - 800 - 900 - 1000 - 1100 - 1200 - 1300 - 1400 - 1500 - 1600 - 1700 - 1800 - 1900 - 2000
032	100 - 200 - 300 - 400 - 500 - 600 - 700 - 800 - 900 - 1000 - 1100 - 1200 - 1300 - 1400 - 1500 - 1600 - 1700 - 1800 - 1900 - 2000
040	100 - 200 - 300 - 400 - 500 - 600 - 700 - 800 - 900 - 1000 - 1100 - 1200 - 1300 - 1400 - 1500 - 1600 - 1700 - 1800 - 1900 - 2000
050	100 - 200 - 300 - 400 - 500 - 600 - 700 - 800 - 900 - 1000 - 1100 - 1200 - 1300 - 1400 - 1500 - 1600 - 1700 - 1800 - 1900 - 2000
063	100 - 200 - 300 - 400 - 500 - 600 - 700 - 800 - 900 - 1000 - 1100 - 1200 - 1300 - 1400 - 1500 - 1600 - 1700 - 1800 - 1900 - 2000

CILINDRO SENZA STELO CON CARRO GUIDATO E GUIDA PRISMatica

RODLESS CYLINDER WITH GUIDED CARRIAGE AND PRISMATIC GUIDE

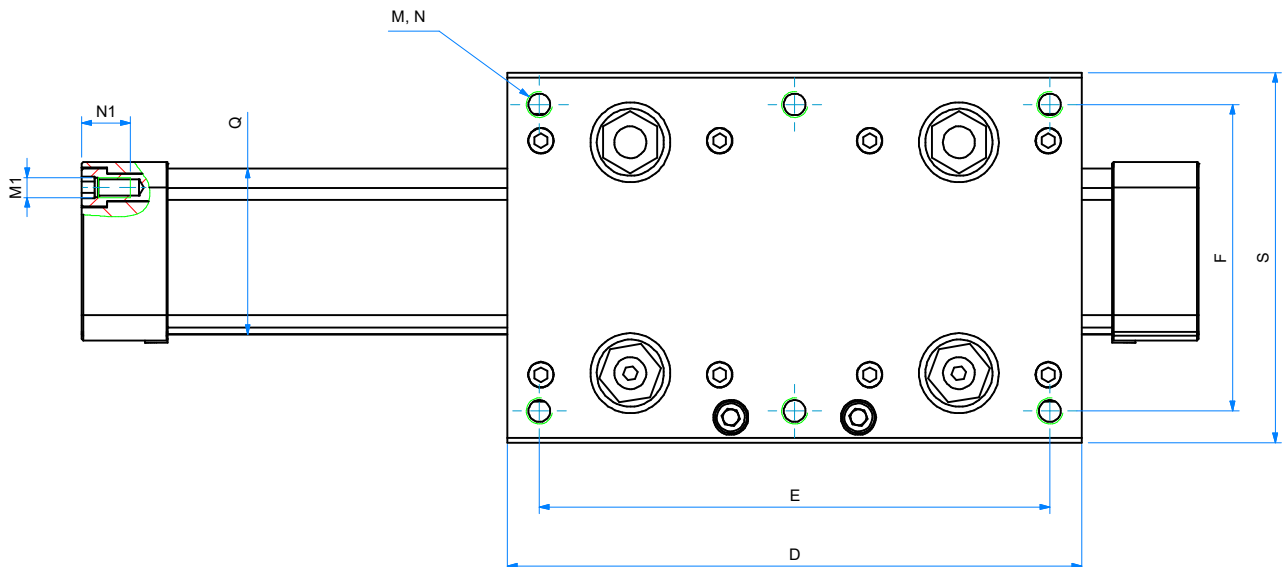
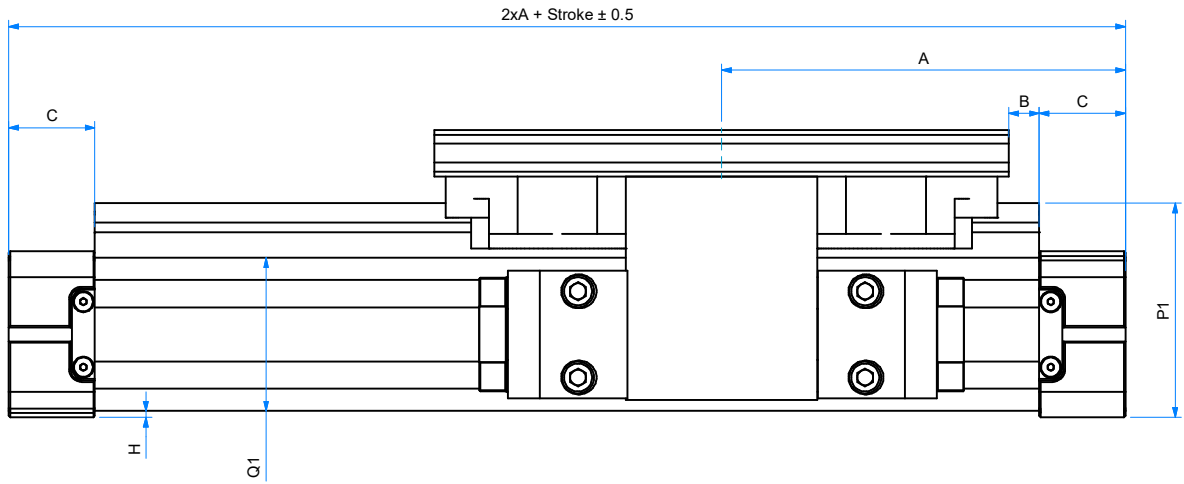
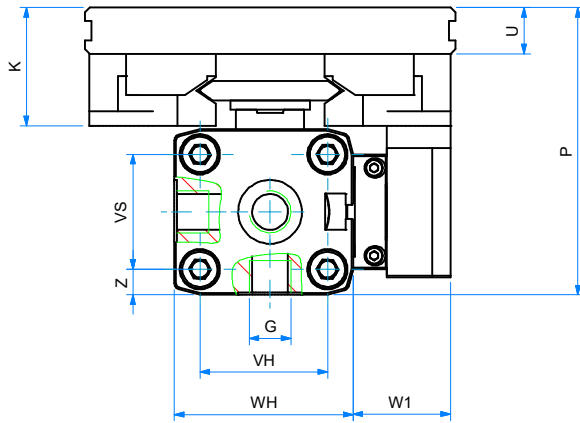
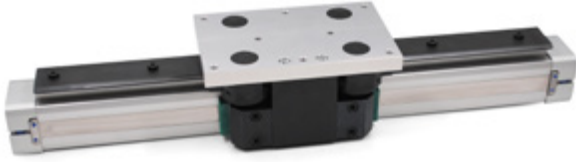

SERIE

D

CILINDRO SENZA STELO CON CARRO GUIDATO E GUIDA PRISMATICA
RODLESS CYLINDER WITH GUIDED CARRIAGE AND PRISMATIC GUIDE

DIMENSIONI - DIMENSIONS				
Ø	025	032	040	050
A+	100	125	150	175
B	9,5	8	0	22
C	23	27	30	33
D	135	180	240	240
E	120	160	216	216
F	65	96	115	115
G	G1/8	G1/4	G1/4	G1/4
H	2	2	6,75	1
K	29,5	37	39	39
M	M6	M8	M8	M8
N	11	14,5	16,5	16,5
M1	M5	M6	M6	M6
N1	10	14	17	18
P	73,5	90	108,5	122
P1	50,5	64,5	84	97,5
QxQ1	36x36	52x48	58,5x59	77x78
S	80	116	135	135
U	11	14,5	16,5	16,5
VH	27	40	54	70
VS	27	36	54	70
WH	40	56	69	80
W1	22	32	34,5	31
Z	6,5	8	9	5

+ = lunghezza corsa - stroke length

Ø	CORSE STANDARD - STANDARD STROKES
025	100 - 200 - 300 - 400 - 500 - 600 - 700 - 800 - 900 - 1000 - 1100 - 1200 - 1300 - 1400 - 1500 - 1600 - 1700 - 1800 - 1900 - 2000
032	100 - 200 - 300 - 400 - 500 - 600 - 700 - 800 - 900 - 1000 - 1100 - 1200 - 1300 - 1400 - 1500 - 1600 - 1700 - 1800 - 1900 - 2000
040	100 - 200 - 300 - 400 - 500 - 600 - 700 - 800 - 900 - 1000 - 1100 - 1200 - 1300 - 1400 - 1500 - 1600 - 1700 - 1800 - 1900 - 2000
050	100 - 200 - 300 - 400 - 500 - 600 - 700 - 800 - 900 - 1000 - 1100 - 1200 - 1300 - 1400 - 1500 - 1600 - 1700 - 1800 - 1900 - 2000

CILINDRO SENZA STELO CON CARRO STANDARD GUIDATO

RODLESS CYLINDER WITH STANDARD GUIDED CARRIAGE

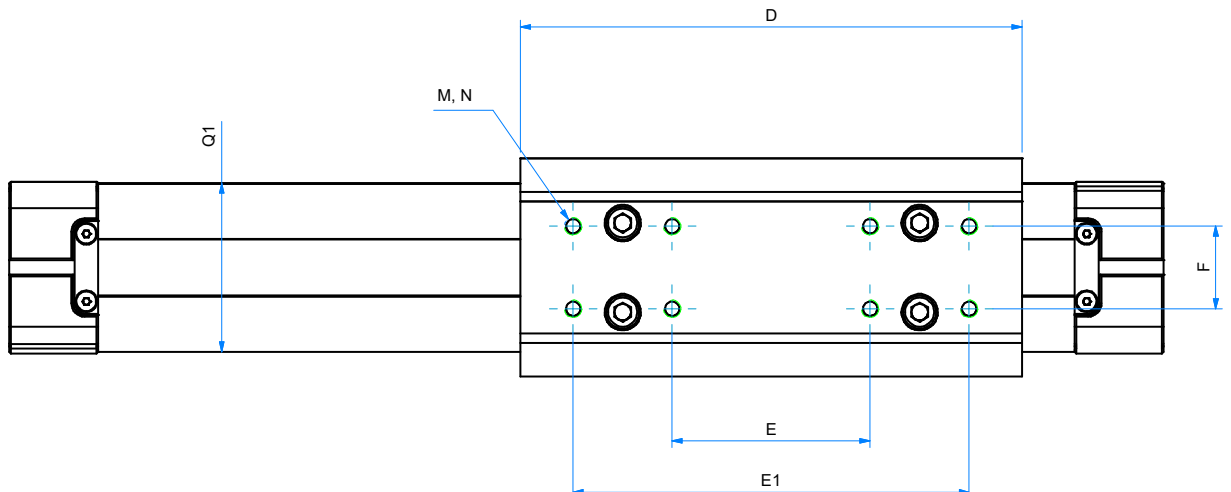
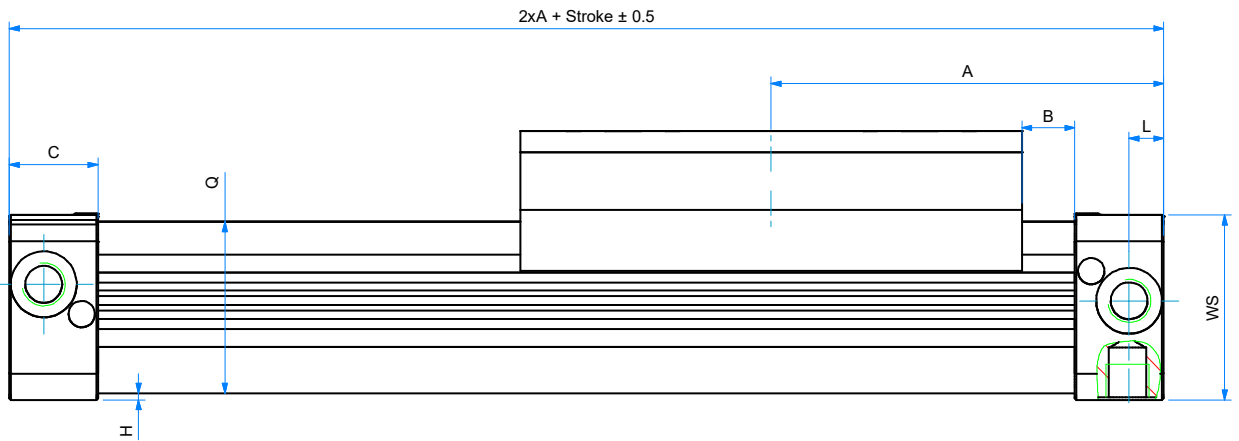
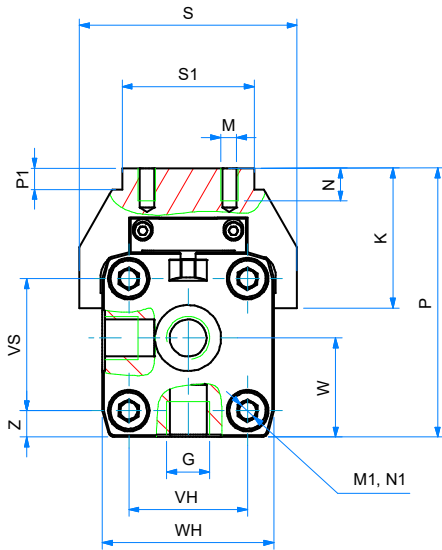

SERIE

D

CILINDRO SENZA STELO CON CARRO STANDARD GUIDATO
RODLESS CYLINDER WITH STANDARD GUIDED CARRIAGE

DIMENSIONI - DIMENSIONS				
Ø	32	40	50	63
A+	125	150	175	215
B	22	12,5	17,5	6,5
C	27	30	33	55
D	152	215	250	320
E	60	68	84	120
E1	120	160	190	240
F	25	25	25	25
G	G1/4	G1/4	G1/4	G3/8
H	2	7	0,5	1,5
K	42,5	44	48,5	56
L	10,5	15	11,7	25
M	M5	M8	M8	M8
N	10	10	10	14
M1	M6	M6	M6	M8
N1	14	17	18	18
P	81,5	97,5	110	137
P1	6,5	6,5	6,5	5
QxQ1	52x51	58,5x59	77x78	102x102
S	66	79	92	116
S1	40	45	50	50
VH	36	54	70	78
VS	40	54	70	78
W	30	36	43,5	62,5
WH	52	72	80	106
WS	56	69	80	106
Z	8	9	4	14,5

+ = lunghezza corsa - stroke length

Ø	CORSE STANDARD - STANDARD STROKES
025	100 - 200 - 300 - 400 - 500 - 600 - 700 - 800 - 900 - 1000 - 1100 - 1200 - 1300 - 1400 - 1500 - 1600 - 1700 - 1800 - 1900 - 2000
032	100 - 200 - 300 - 400 - 500 - 600 - 700 - 800 - 900 - 1000 - 1100 - 1200 - 1300 - 1400 - 1500 - 1600 - 1700 - 1800 - 1900 - 2000
040	100 - 200 - 300 - 400 - 500 - 600 - 700 - 800 - 900 - 1000 - 1100 - 1200 - 1300 - 1400 - 1500 - 1600 - 1700 - 1800 - 1900 - 2000
050	100 - 200 - 300 - 400 - 500 - 600 - 700 - 800 - 900 - 1000 - 1100 - 1200 - 1300 - 1400 - 1500 - 1600 - 1700 - 1800 - 1900 - 2000

ACCESSORI DI FISSAGGIO CILINDRI SENZA STELO

RODLESS CYLINDER MOUNTING PARTS

DIAGRAMMA DI FLESSIONE

DEFLECTION DIAGRAM

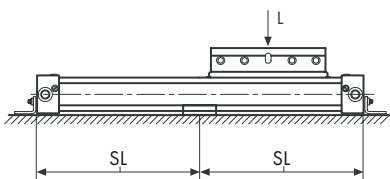
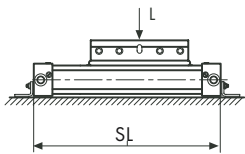
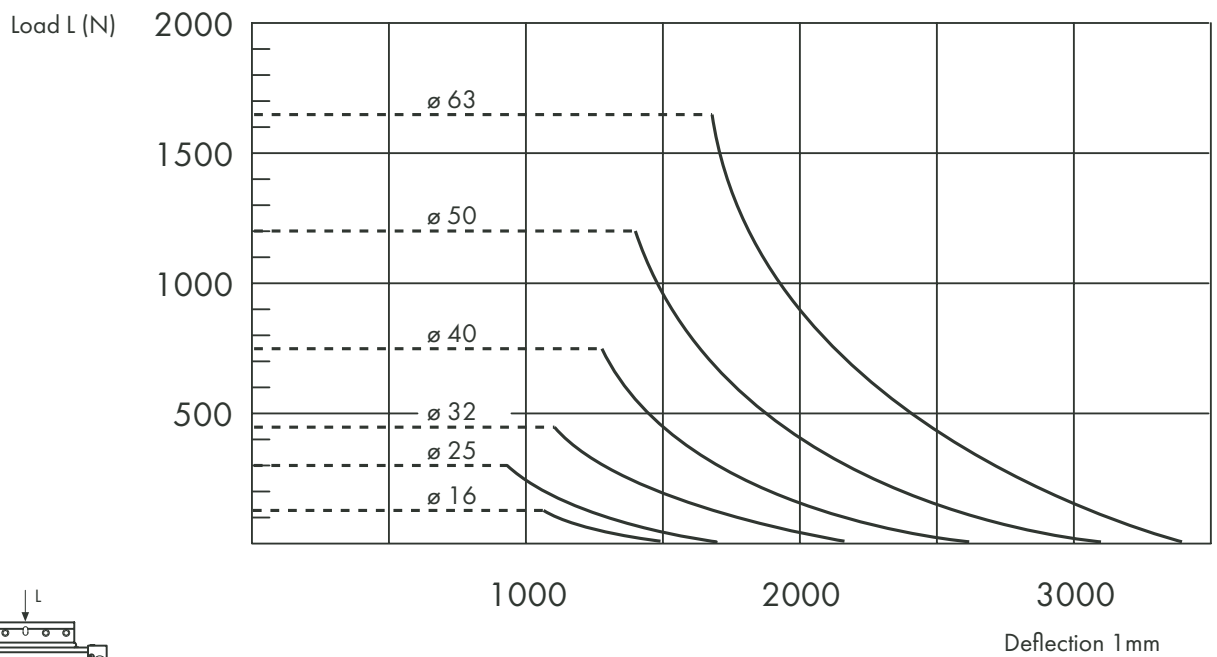

max. distance (SL) in mm - free of mounting No. 25

SERIE

D

PIEDINO BASSO
FOOT MOUNTING

Ø 16-25

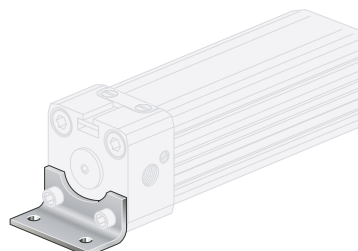
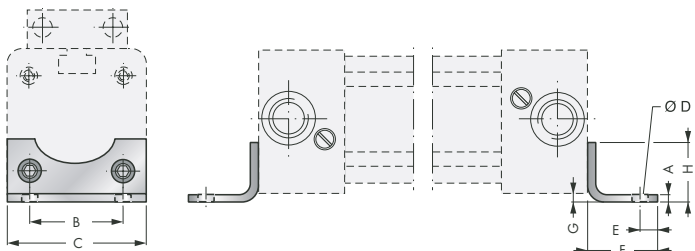

Ø 32 ÷ 63

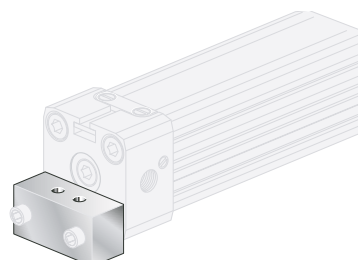
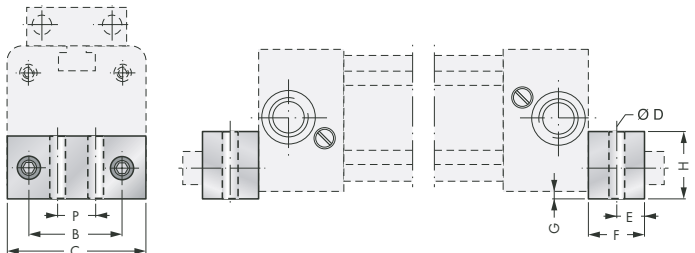

 MATERIALE:
 ACCIAIO ZINCATO
 MATERIAL:
 ZINC COATED STEEL

PIEDINO INTERMEDIO
MID SECTION FOOT MOUNTING

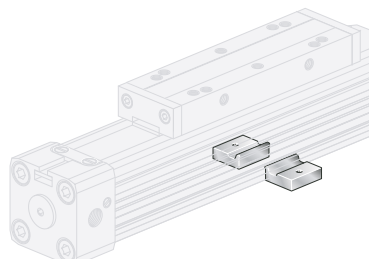
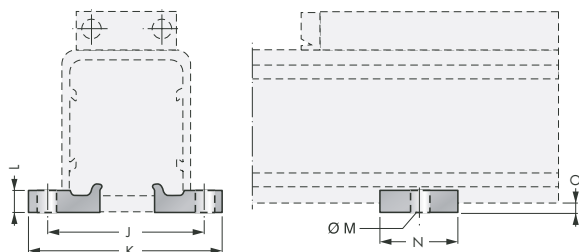
Ø 16-25

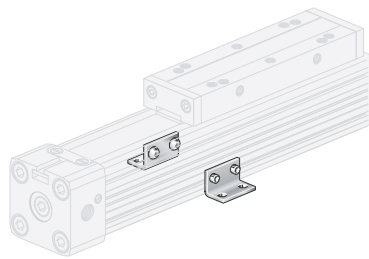
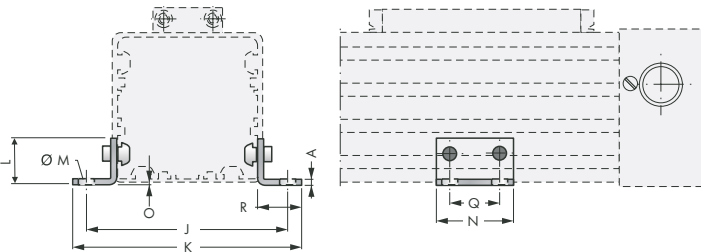

Ø 32 ÷ 63



 MATERIALE:
 ALLUMINIO ANODIZZATO
 MATERIAL:
 ANODIZED ALUMINUM

 SERIE
D
DIMENSIONI - DIMENSIONS

Ø	A	B	C	D	E	F	G	H	J	K	L	ØM	N	O	P	Q	R
16	1,5	18	26	3,6	4	14	1,5	12,5	41,5	53,5	5	5,5	20	3	-	-	-
25	2,5	27	40	5,5	6	22	2	18	48,5	60	6	5,5	20	4	-	-	-
32	5	36	51	6,5	8	24	4	20	82	91	30	4,5	45	6	20	30	20
40	5	54	71	9	11,5	24	2	20	90	99	25	4,5	45	8,5	30	30	20
50	5	70	80	9	12,5	25	1	25	123	148	35	6,5	45	1	45	30	35
63	5	78	105	11	15	30	2	40	147	172	35	6,5	45	3,5	48	30	35

SUPPORTO INTERMEDIO TIPO C

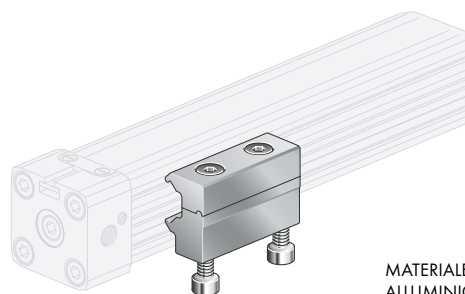
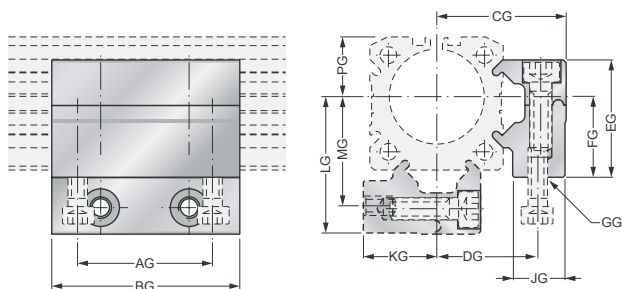
MOBILE MID SECTION SUPPORT C TYPE



MATERIALE:
ALLUMINIO ANODIZZATO
MATERIAL:
ANODIZED ALUMINUM

DIMENSIONI - DIMENSIONS

Ø	AG	BG	CG	DG	EG	FG	GG	JG	KG	LG	MG	PG
16	18	30	27,5	18,4	21	15	M4	11,5	13,9	29	19,7	10,8
25	36	50	34,5	27	31,3	22	M5	14	20	36,5	29	16
32	36	50	41,8	34,2	39	30	M6	14	27,6	47	39,5	21,5

SUPPORTO INTERMEDIO TIPO CL

MOBILE MID SECTION SUPPORT CL TYPE

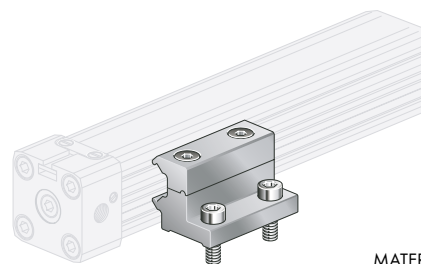
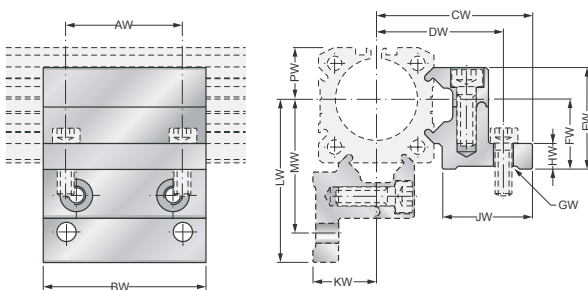

MATERIALE:
ALLUMINIO ANODIZZATO
MATERIAL:
ANODIZED ALUMINUM

DIMENSIONI - DIMENSIONS

Ø	AW	BW	CW	DW	EW	FW	ØGW	HW	JW	KW	LW	MW	PW
16	18	30	37	32,5	21	15	4,5	6	22,4	13,9	38	32,9	10,8
25	36	50	47,5	40	31,3	22	5,5	10	26	20	49,5	42	16
32	36	50	56	47,5	39	30	6,5	10	28,5	27,6	61	52,5	21,5

SERIE

D

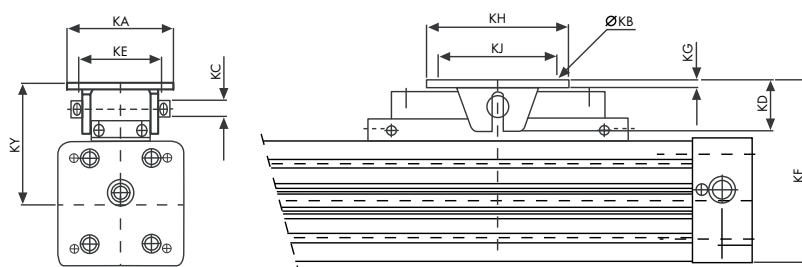
FLANGIA BASCULANTE
ARTICULATED CARRIER

MATERIALE:
ACCIAIO ZINCATO
MATERIAL:
ZINC COATED STEEL

DIMENSIONI - DIMENSIONS

\emptyset	KA	KB	KD	KE	KF	KG	KH	KJ	KY
16	26	M4	10	10	46,5 - 47,5	3	28	20	33
25	38	M5	19	16	71,5 - 73,5	3,5	40	30	51,5
32	62	M6	28	25	94,5 - 96,5	6	60	46	66,5
40	62	M6	28	25	108 - 110	6	60	46	73,5
50	90	9	43,7	70	135 - 150	6,4	120	100	95 - 110
63	90	9	43,7	70	155 - 170	6,4	120	100	102 - 117

SENSORI MAGNETICI

MAGNETIC SENSORS

CARATTERISTICHE - CHARACTERISTICS					
CODICE - CODE		36.SEN06 36.SEN06.L6	36.SEN07	36.SEN08	36.SEN09 36.SEN09.L6 36.SEN09.L10
TIPO - TYPE		REED	REED	ELETTRONICO ELECTRONIC	ELETTRONICO ELECTRONIC
Modello elettrico - Electrical design		AC/DC PNP/NPN	AC/DC PNP/NPN	DC PNP	DC PNP
Funzione dell'uscita - Output		NO	NO	NO	NO
Tensione di esercizio - Operating voltage	[V]	5...120 AC/DC	5...60 DC / 5...50 AC	10...30 DC	10...30 DC
Capacità di corrente - Current rating	[mA]	100*	100*	100	100
Sensibilità di reazione - Magnetic sensitivity	[mT]	2,1	2,1	2,8	2,8
Velocità di passaggio - Travel speed	[m/s]	> 10	> 10	> 10	> 10
Protezione da cortocircuito - Short-circuit proof		no	no	si - yes	si - yes
Protetto da inversione di polarità Reverse polarity protection		si - yes	si - yes	si - yes	si - yes
Resistente a sovraccarico - Overload protection		no	no	si - yes	si - yes
Caduta di tensione - Voltage drop	[V]	< 5	< 5	< 2,5	< 2,5
Isteresi - Hysteresis		1	1	< 1,5	< 1,5
Riproducibilità - Repeatability	[mm]	± 0,2	± 0,2	< 0,2	< 0,2
Corrente assorbita - Current consumption	[mA]	-	-	< 10	< 10
Tempo di commutazione - Make time	[ms]	≤ 0,6	≤ 0,6	-	-
Tempo di riapertura - Fall time	[ms]	≤ 0,1	≤ 0,1	-	-
Potenza max - Switching power max	[W]	10	10	-	-
Cicli di commutazione con connessione a PLC Switching cycles when connected to PLC	[mln]	≤ 40	≤ 40	-	-
Frequenza di commutazione - Switching frequency	[Hz]	1.000	1.000	> 10.000	> 10.000
Temperatura ambiente - Ambient temperature	[°C]	-25...70	-25...70	-25...80	-25...80
Grado/Classe di protezione - Protection		IP67, II	IP67, II	IP67, III	IP67, III
Materiale involucro - Housing material		PA (poliammide - polyamide)			
Materiale eccentrico di fissaggio - Fastening clamp		inox - stainless steel			
Indicazione della funzione Stato di commutazione Function display Switching status	LED	giallo - yellow			
Collegamento - Connection		cavo PUR - PUR cable 2x0,14 mm ² 2 m (.L6 = 6 m)	cavo PUR - PUR cable connettore M8- M8 connector 0,3 m	cavo PUR - PUR cable connettore M8- M8 connector 0,3 m	cavo PUR - PUR cable 3x0,14 mm ² 2 m (.L6 = 6 m .L10 = 10 m)
Peso - Weight	[g]	31,3 69	12	12,1	27,4 73,5 122,4

Accessori inclusi: Segnaposto in gomma, fascetta fermacavo - Accessories included: Rubber placeholder, cable clip

*: necessario circuito di protezione esterno per carico induttivo (valvola, relè, ecc...). - External protective circuit for inductive load (valve, contactor, etc...) necessary.

REED: nessuna funzione LED in caso di inversione di polarità nel funzionamento DC. - No LED function in case of polarity reversal in DC operation.

SERIE

D

CONTATTO REED (2 FILI)

36.SEN06

36.SEN06.L6

REED CONTACT (2 WIRES)

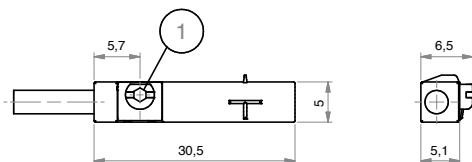

1= ECCENTRICO DI FISSAGGIO - FASTENING CLAMP

CABLAGGIO - WIRING

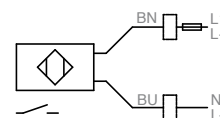

BN= MARRONE - BROWN

BU= BLU - BLUE

CONTATTO REED (CONNETTORE M8)

36.SEN07

REED CONTACT (M8 CONNECTOR)

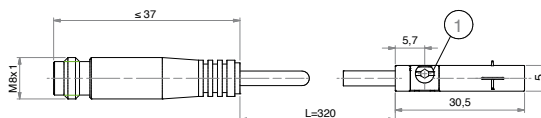

1= ECCENTRICO DI FISSAGGIO - FASTENING CLAMP

CABLAGGIO - WIRING

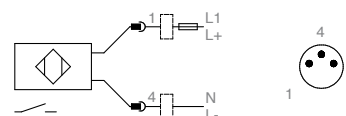

BN= MARRONE - BROWN

BU= BLU - BLUE

CONTATTO PNP (CONNETTORE M8)

36.SEN08

PNP CONTACT (M8 CONNECTOR)

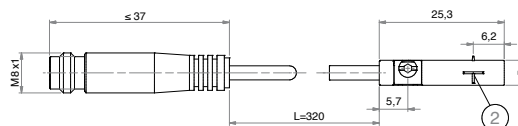

1= ECCENTRICO DI FISSAGGIO
FASTENING CLAMP

2= SUPERFICIE ATTIVA
SENSING FACE

CABLAGGIO - WIRING

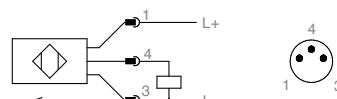

BN= MARRONE - BROWN

BU= BLU - BLUE

SERIE

D

CONTATTO PNP (3 FILI)

36.SEN09

36.SEN09.L6

36.SEN09.L10

PNP CONTACT (3 WIRES)

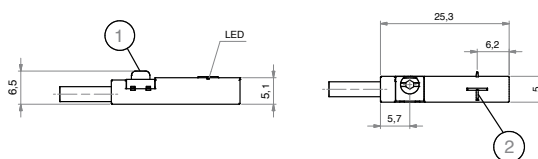

1= ECCENTRICO DI FISSAGGIO - FASTENING CLAMP

2= SUPERFICIE ATTIVA - SENSING FACE

CABLAGGIO - WIRING

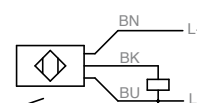

BK= NERO - BLACK

BN= MARRONE - BROWN

BU= BLU - BLUE

CAVO PROLUNGA (CONNETTORE M8)

EXTENSION CABLE (M8 CONNECTOR)

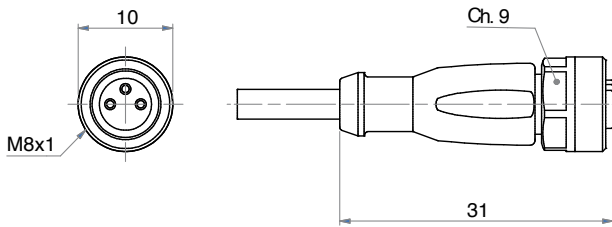

1	BN
3	BU
4	BK

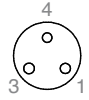

ADATTATORE PER CILINDRO SENZA STELO Ø 16-25-(Ø 32 C2-C3-C4)

SENSOR MOUNTING FOR RODLESS CYLINDERS Ø 16-25-(Ø 32 C2-C3-C4)

