

SERIE

W

ACCESSORI
ACCESSORIES



ARTEC[®]
PNEUMATIC COMPONENTS

UNITÀ DI GUIDA

GUIDE UNIT

UNITÀ DI GUIDA - GUIDE UNITS

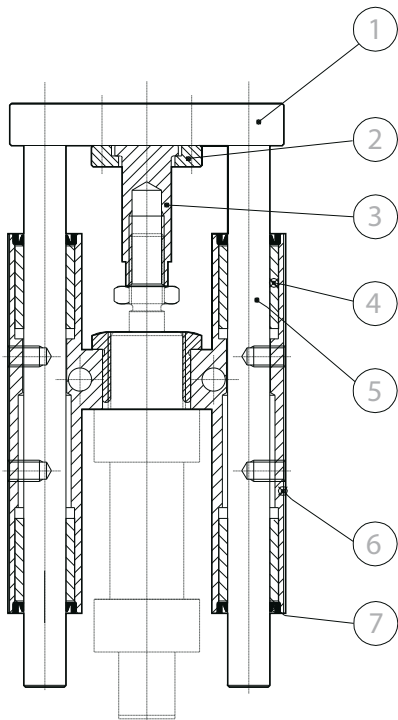
SERIE
O
SERIE
H



CARATTERISTICHE COSTRUTTIVE - CONSTRUCTIVE CHARACTERISTICS

①	Piastra - Plate	alluminio anodizzato - <i>anodized aluminium</i>
②	Ghiera - Slotted nut	acciaio zincato - <i>zinc coated steel</i>
③	Giunto - coupling	acciaio zincato - <i>zinc coated steel</i>
④	Boccola guida - Slide bearing	bronzo - <i>bronze</i>
⑤	Stelo - Rod	acciaio cromato - <i>chromed steel</i>
⑥	Corpo - Body	alluminio anodizzato - <i>anodized aluminium</i>
⑦	Raschiastelo - Scraper	NBR

CHIAVE DI CODIFICA

KEY CODE

G H X 0 5 0 . 1 0 0 . S			
	ALESAGGIO - BORE (Ø)	CORSA - STROKE (mm)	GIUNTO - COUPLING
	016-020-025-032-040 050-063-080-100	050-100-160-200 250-320-400-500 600-700-800-900-1000	S giunto corto <i>short coupling</i>
			L giunto lungo <i>long coupling</i>
VERSIONE - VERSION			
H	tipo H con boccole in bronzo <i>H type with bronze bushes</i>		
HX	tipo H con boccole in bronzo e steli in acciaio inox AISI 304 <i>H type with bronze bushes and AISI 304 SS rods</i>		
HS	tipo H con cuscinetti a ricircolo di sfere e steli in acciaio cromato <i>H type with recirculating ball bearings and chromed steel rods</i>		
U	tipo U con boccole in bronzo <i>U type with bronze bushes</i>		
UX	tipo U con boccole in bronzo e steli in acciaio inox AISI 304 <i>U type with bronze bushes and AISI 304 SS rods</i>		
SERIE - SERIES			
G	unità di guida <i>guide unit</i>		

DIAGRAMMA CARICO AMMISSIBILE

ALLOWABLE LOAD



DIAGRAMMA CARICO AMMISSIBILE

ALLOWABLE LOAD

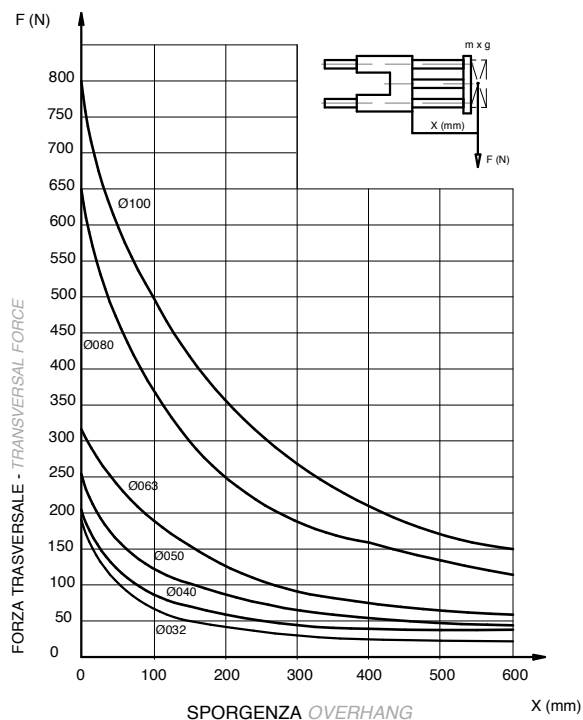

DIAGRAMMA CARICO AMMISSIBILE

ALLOWABLE LOAD

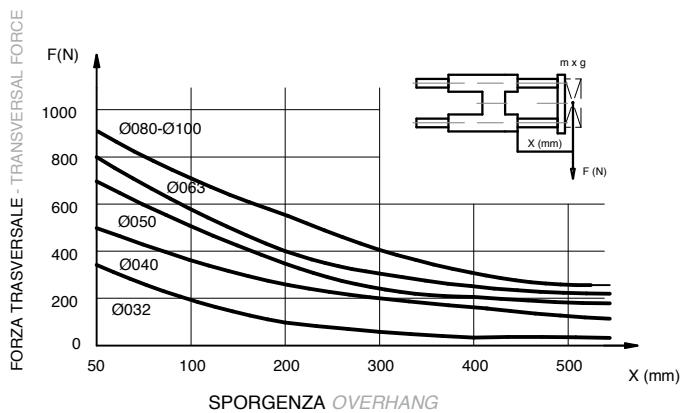
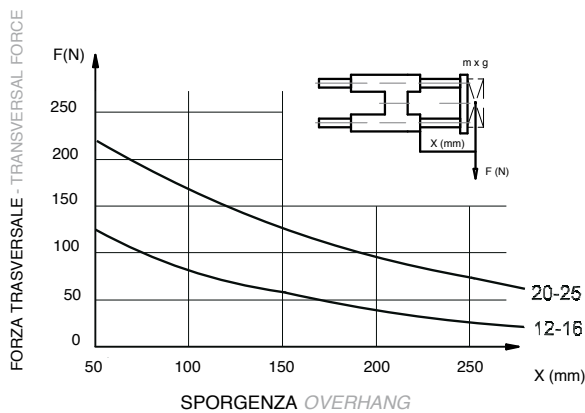
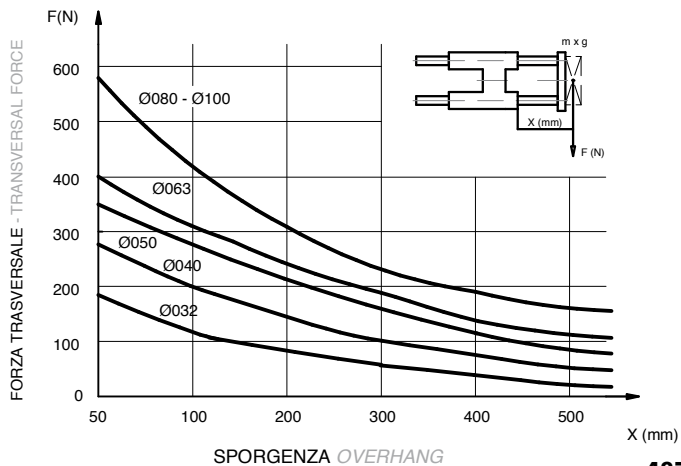
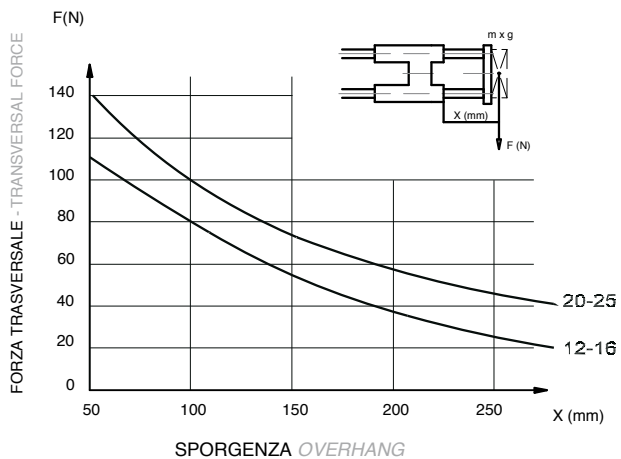

DIMENSIONI

DIMENSIONS

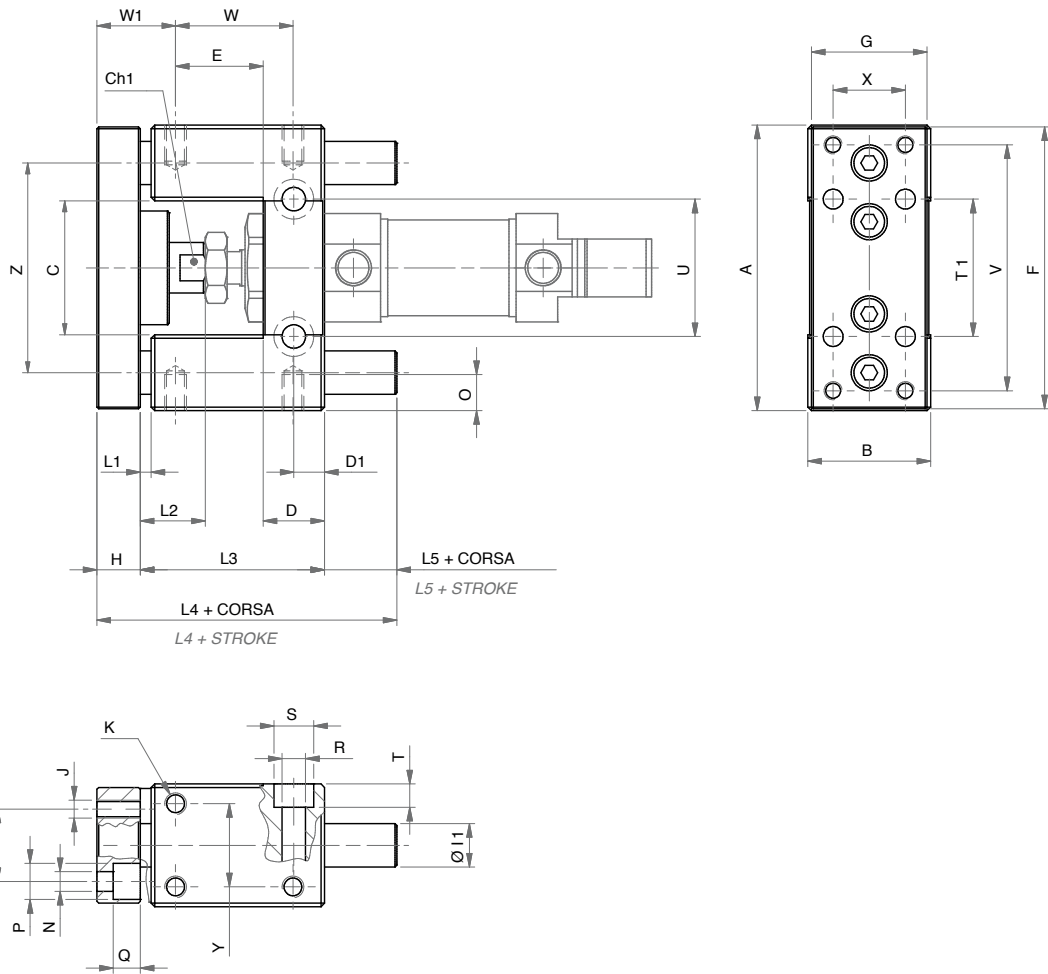

GIUNTO CORTO - SHORT COUPLING

Ø	A	B	C	Ch1	D	D1	E	F	G	H	Ø11	J	K	L1	L2	L3
12 - 16	69	30	30	8	12	6	19	66	29	10	10	M4	M4	3	15	38
20 - 25	79	34	37	12	17	8,5	24,25	78	32	12	12	M5	M6	3	18	48

Ø	L4	L5	N	O	P	Q	R	S	T	T1	U	V	W	W1	X	Y	Z
12 - 16	66,5	15,5	4,5	6	8	4,5	5,5	9	5,5	32	24	58	25	20	18	22	49,5
20 - 25	83	20	5,5	9	10	7,5	6,5	11	6,5	38	38	68	32,5	21,75	20	23	58

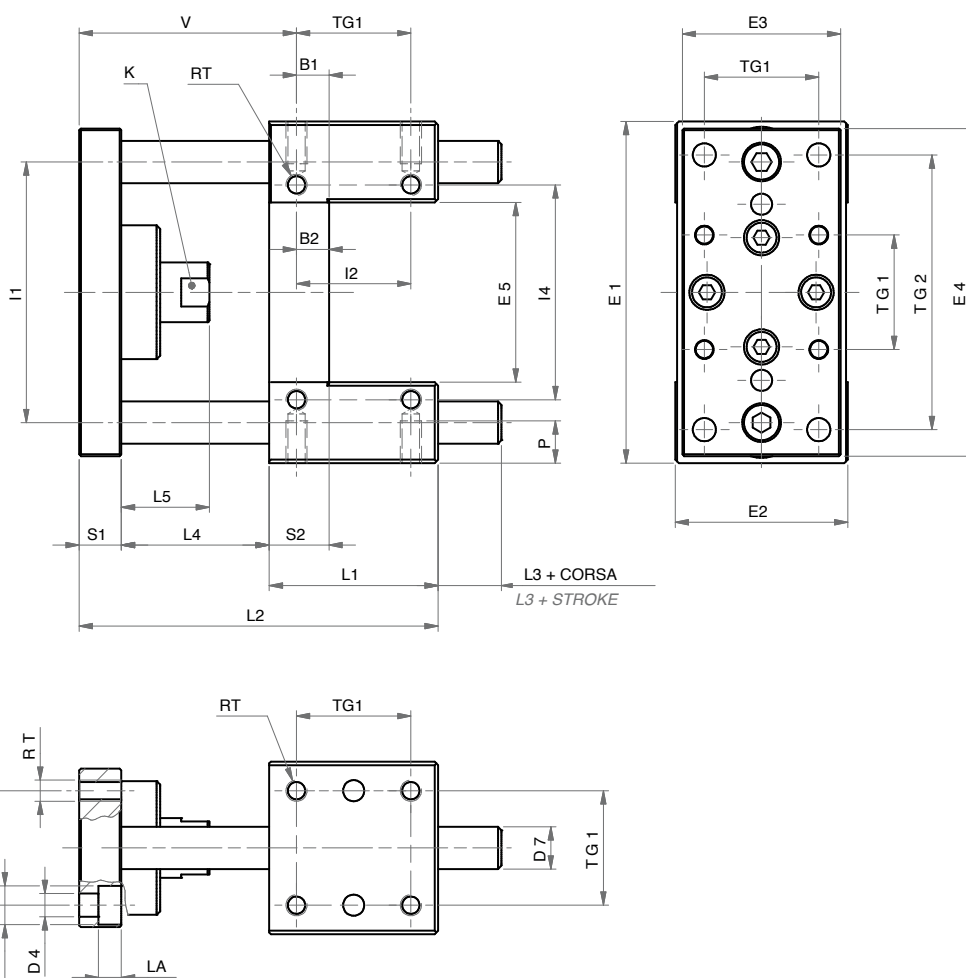
DIMENSIONI
DIMENSIONS

GIUNTO CORTO - SHORT COUPLING

Ø	B1	B2	D4	D5	D7	E1	E2	E3	E4	E5	I1	I2	I4	K	L1	L2	L3	L4	L5	LA	P	RT	S1	S2	TG1	TG2	V
32	9,25	9,25	6,6	11	12	97	49	45	93	51	74	32,5	61	15	48	102	18	42	25	6,5	12	M6	12	17	32,5	78	61,75
40	11	11	6,6	11	16	115	58	55	112	58,2	87	38	69	15	58	113	17	43	25	6,5	12	M6	12	21	38	84	65
50	18,8	18,8	9	15	20	137	70	65	134	70,2	104	46,5	85	20	59	123	20	49	29	8,5	16	M8	15	25	46,5	100	70,2
63	15,3	15,3	9	15	20	152	85	80	147	85,2	119	56,5	100	20	76	140	21	49	29	9	16	M8	15	25	56,5	105	73,7
80	25	14	11	18	25	189	105	100	180	105,5	148	50	130	26	90	163	30	53	37	11	20	M10	20	34	72	130	82
100	28,5	19	10,5	16,5	25	23	130	120	206	130,5	173	70	150	26	110	184	30	54	37	11	20	M10	20	39	89	150	84,5

DIMENSIONI

DIMENSIONS

UNITÀ DI GUIDA - GUIDE UNITS

SERIE

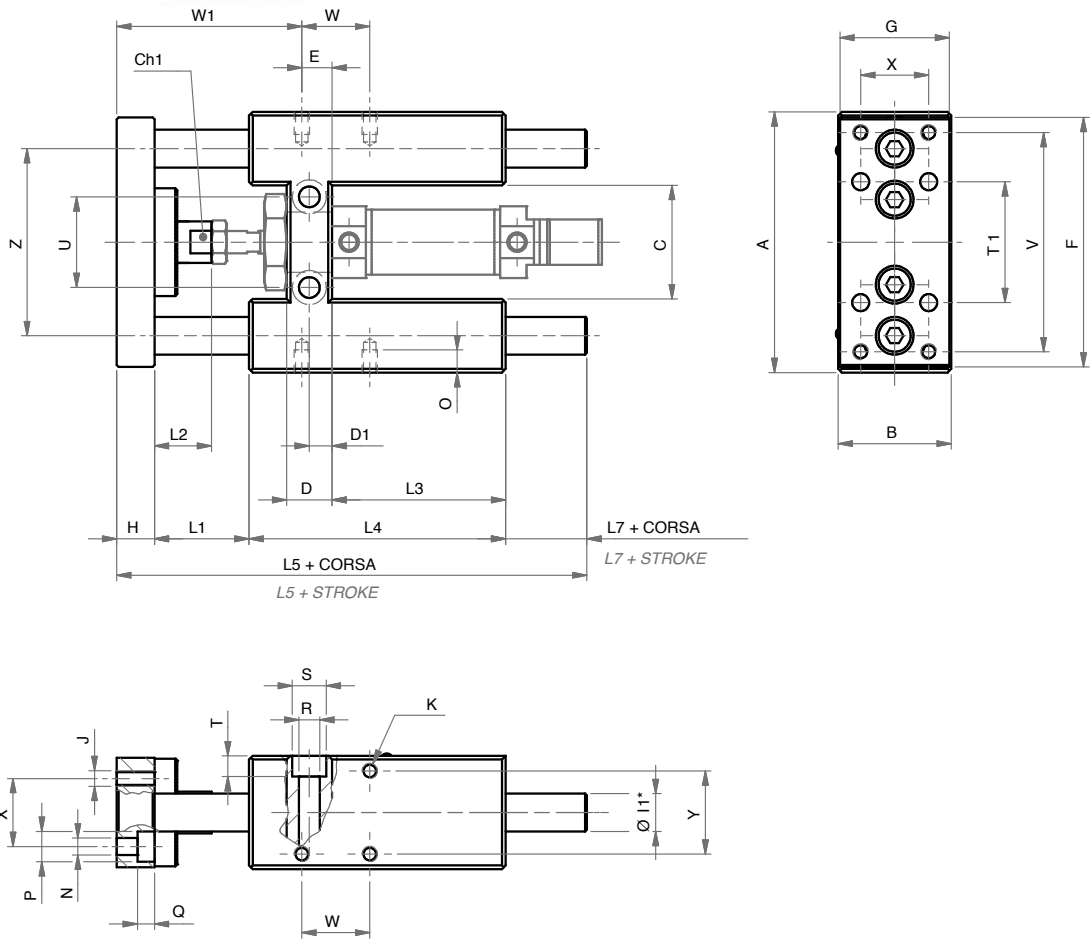

* : Ø11 per unità di guida con boccole in bronzo - for unit guide with bronze bush
 * : Ø12 per unità di guida con cuscinetti a ricircolo di sfere - for unit guide with recirculating ball bearings

GIUNTO LUNGO - LONG COUPLING

Ø	L1	L2	W1
12 - 16	25	18	49
20 - 25	25	40	72

GIUNTO CORTO - SHORT COUPLING

Ø	A	B	C	Ch1	D	D1	E	F	G	H	Ø 11	Ø 12	J	K	L1	L2	L3	L4
12 - 16	69	30	30	8	12	6	8	66	29	10	10	8	M4	M4	22	15	46	68
20 - 25	79	34	37	12	17	8,5	15	78	32	12	12	10	M5	M6	3	18	58	108

Ø	L5	L7	N	O	P	Q	R	S	T	T1	U	V	W	W1	X	Y	Z
12 - 16	121,5	21,5	4,5	6	8	45	55	9	5,5	32	30	58	18	46	18	22	49,5
20 - 25	144	21	5,5	9	10	7,5	6,5	11	6	38	37	68	32,5	50	20	23	58

SERIE

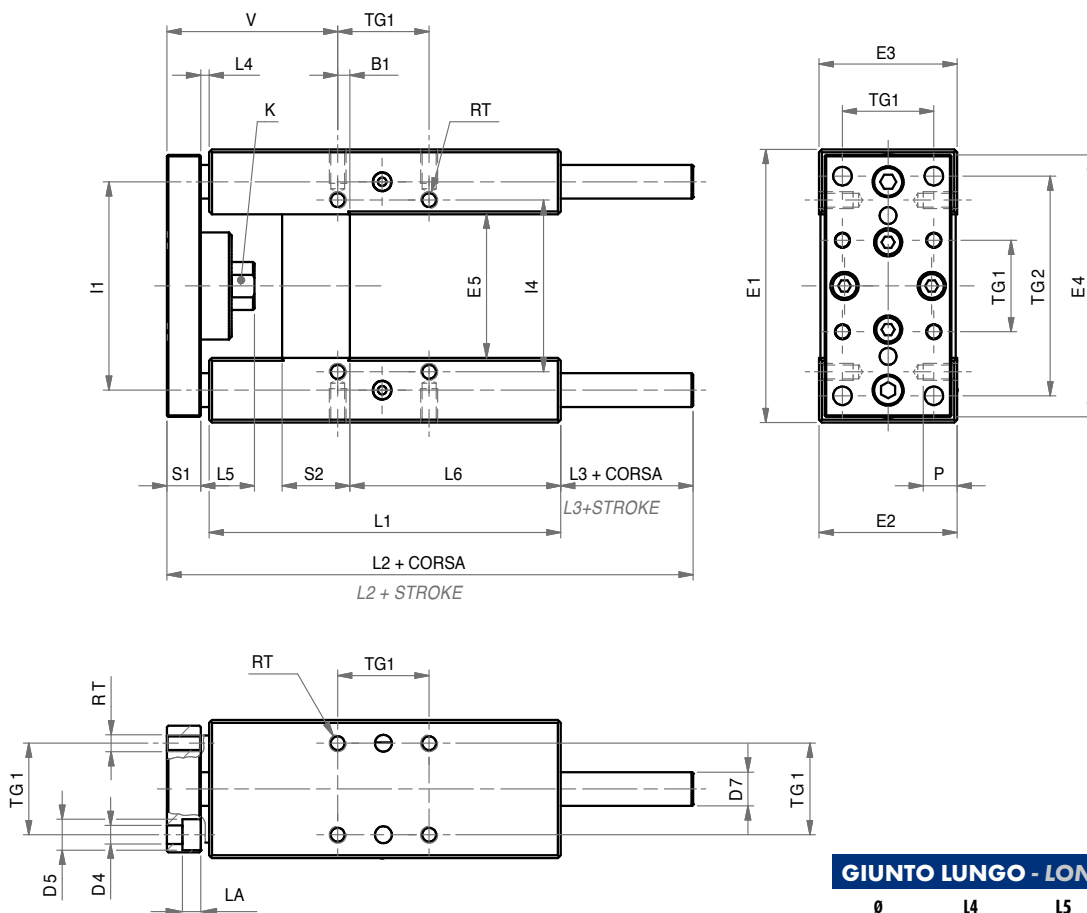

DIMENSIONI
DIMENSIONS

GIUNTO LUNGO - LONG COUPLING

Ø	L4	L5	L3	V
32	25	42	25	82,7
40	25	42	30	86
50	25	50	35	91,2
63	25	50	25	96,7
80	25	50	27	104
100	25	50	27	105

GIUNTO CORTO - SHORT COUPLING

Ø	B1	D4	D5	D7	E1	E2	E3	E4	E5	I1	I4	K	L1	L2	L3	L4	L5	L6	LA	P	RT	S1	S2	TG1	TG2	V
32	4,3	6,6	11	12	97	49	45	93	51	74	61	15	125	187	47	3	19,1	75	6,5	12	M6	12	24	32,5	78	60,7
40	11	6,6	11	16	115	58	55	112	58,2	87	69	15	140	207	52	3	24	80	6,5	12	M6	12	28	38	84	64
50	18,8	9	15	20	137	70	65	134	70,2	104	85	20	148	223	57	3	27	78	8,5	16	M8	15	34	46,5	100	69,2
63	15,3	9	15	20	152	85	80	147	85,2	119	100	20	178	243	47	3	27	106	9	16	M8	15	34	56,5	105	74,7
80	25	11	18	25	189	105	100	180	105,5	148	130	26	195	267	49	3	27	111	11	20	M10	20	50	72	130	82
100	30	11	18	25	213	130	120	206	130,5	173	150	26	218	290	49	3	27	128	11	20	M10	20	55	89	150	83

BLOCCASTELO
ROD LOCK
CARATTERISTICHE TECNICHE - TECHNICAL CHARACTERISTICS

Pressione di esercizio - Working pressure	3 ÷ 6 bar									
Temperatura di esercizio - Working temperature	-5 ÷ +80°C (con aria secca - with dry air)									
Alesaggi - Bores	ø 020 - 025 - 032 - 040 - 050 - 063 - 080 - 100 - 125									
Tipo di bloccaggio - Type of locking	Meccanico bidirezionale - Mechanical bi-directional									
Fluido - Fluid	aria compressa filtrata, non lubrificata - compressed filtered, non lubricated air									
Forza bloccaggio - Locking force	ø	20	25	32	40	50	63	80	100	125
	[N]	490	490	790	1240	1930	3060	5400	7700	12040

ATTENZIONE

Il funzionamento del bloccastelo è di tipo statico (stelo cilindro non in movimento). È necessario arrestare lo stelo del cilindro prima di effettuare il bloccaggio. È possibile sbloccare il bloccastelo solo se le forze nel pistone sono equilibrate, altrimenti si possono verificare incidenti a causa del movimento irregolare dello stelo. Se vengono superati i valori di bloccaggio indicati, si possono verificare slittamenti dello stelo. In condizioni di bloccaggio e con carichi variabili sullo stelo, lo stelo può avere un leggero gioco assiale.

Non togliere l'alimentazione dell'aria in assenza del falso stelo o dello stelo del cilindro

ATTENTION

Rod lock's functioning is of static type (cylinder rod must be stopped). It is necessary to stop the cylinder rod before locking it. It is possible to unblock the rod lock only if the forces in the piston are balanced, otherwise there can be accidents due to the irregular movement of the rod. If the given blocking values are exceeded there can be a sliding on the rod. When it is blocked and the loads are variable on the rod, the rod can have a slight axial play.

Don't remove air feeding when "false" rod or cylinder rod is missing.

CARATTERISTICHE COSTRUTTIVE - CONSTRUCTIVE CHARACTERISTICS

①	Boccola - Bush	delrin
②	Dado - Nut	acciaio zincato - zinc coated steel
③ ④	Molla - Spring	acciaio - steel
⑤ ⑦	Coperchio - Cover	alluminio - aluminium
⑥	Guarnizioni - Seals	poliuretano - polyurethane
⑧ ⑬	Guarnizioni - Seals	NBR
⑨	Pistone - Piston	delrin
⑩	Disco molla - Spring cover	delrin
⑪	Corpo - Body	alluminio anodizzato - anodized aluminium
⑫	Palette - Jaws	bronzo - bronze
	Viti - Screws	acciaio zincato - zinc coated steel

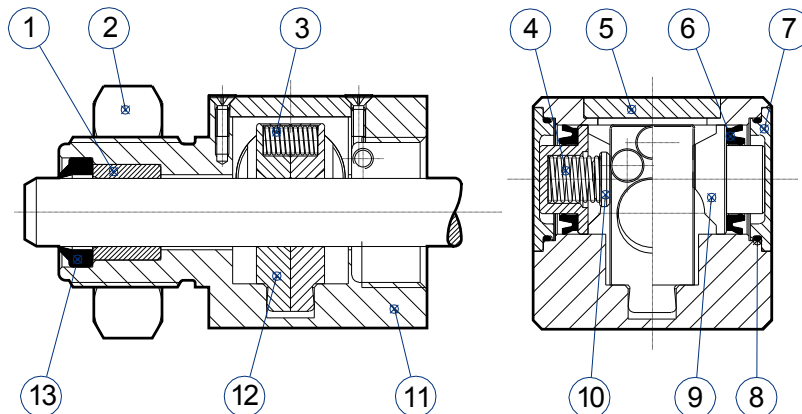

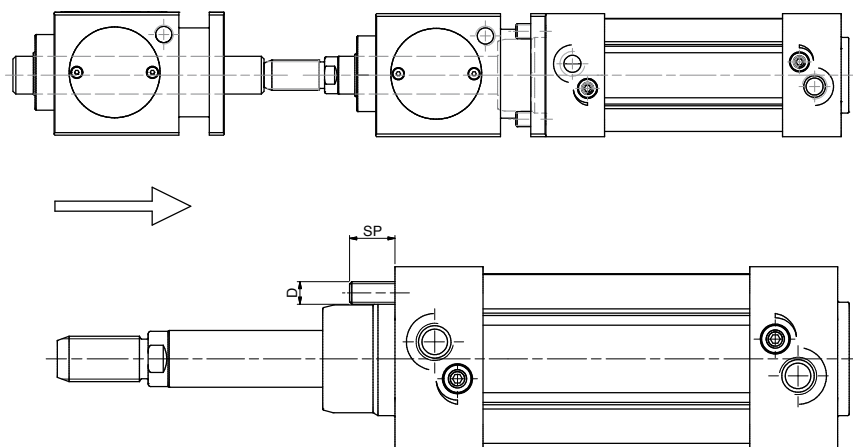
MONTAGGIO
ASSEMBLY

MONTAGGIO - INSTALLATION

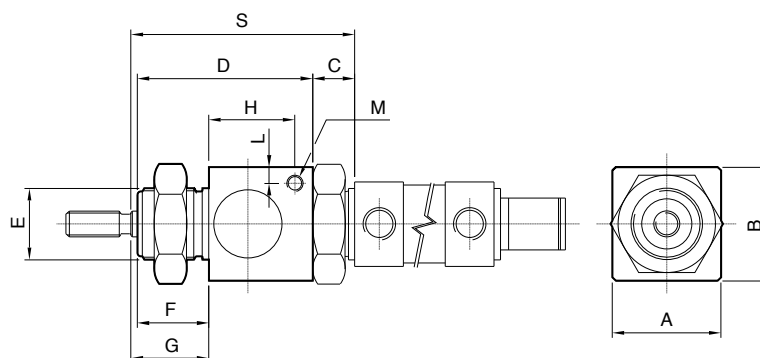
CILINDRO \varnothing - \varnothing CYLINDER	32	40	50	63	80	100	125
SP	12	12	16	16	22	22	32
D	M6	M6	M8	M8	M10	M10	M12

BLOCCASTELO
ROD LOCK

DIMENSIONI - DIMENSION

COD.	A	B	C	D	E	F	G	H	L	M	S
BH020	34	35	13	54	M22x1,5	22	26	27	5	M5	71
BH025	34	35	13	54	M22x1,5	22	28	27	5	M5	73

!!!: Non togliere l'alimentazione dell'aria in assenza dello stelo - Don't stop air in the absence of the rod

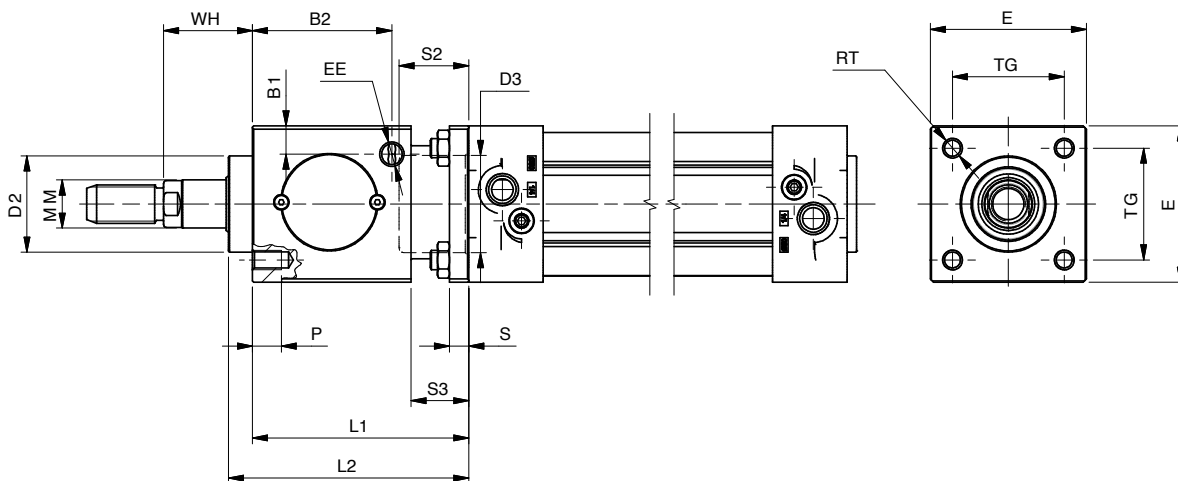
Il funzionamento del bloccastelo è di tipo statico (stelo non in movimento). È necessario arrestare lo stelo del cilindro prima di effettuare il bloccaggio.
The rod lock operation is static (rod not moving). The rod must be stopped before locking.

BLOCCASTELO
ROD LOCK
BLOCCASTELO - ROD LOCKS
SERIE

DIMENSIONI - DIMENSION

COD.	B1	B2	ø D2	D3	E	EE	L1	L2	ø MM	P	RT	S	S2	S3	TG	WH
BH032	9	33,25	30	30,5	47	1/8"G	60	67,5	12	8	M6	6	19,5	20	32,5	26
BH040	9	42,5	34,9	35,5	54	1/8"G	70	80	16	8	M6	6	22,5	20	38	30
BH050	12,5	58	40	40,5	65	1/8"G	90	100	20	12	M8	8	29	24	46,5	37
BH063	17,5	59	45	45,5	75	1/8"G	90	100	20	12	M8	8	29	24	56,5	37
BH080	17,5	69	45	45,5	95	1/4"G	110	120	25	16	M10	12	37	32	72	46
BH100	20	69	55	55,5	114	1/4"G	110	120	25	16	M10	12	39	32	89	51
BH125	19	84,5	60	60,5	138	1/4"G	140	156	32	20	M12	20	51,5	45	110	65

III: Non togliere l'alimentazione dell'aria in assenza dello stelo - Don't stop air in the absence of the rod

 Il funzionamento del bloccastelo è di tipo statico (stelo non in movimento). È necessario arrestare lo stelo del cilindro prima di effettuare il bloccaggio.
 The rod lock operation is static (rod not moving). The rod must be stopped before locking.

SOFFIETTO MODULARE

BLW

MODULAR BELLOWS

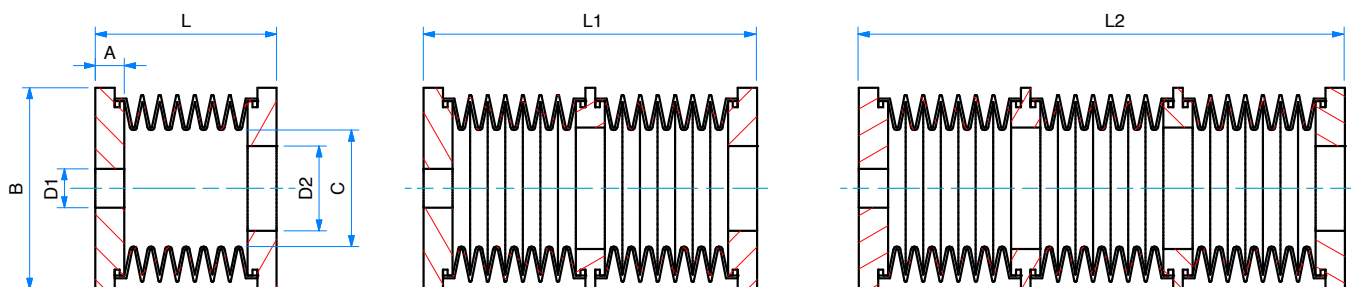

DIMENSIONI - DIMENSION

		SERIE 60	SERIE 83	SERIE 106	SERIE 106L	SERIE 135
\varnothing		32	40-50-63-80	100-125-160	100-125	160-200
A		12	12	12	12	12
B		60	83	106	106	135
D1-D2	min	10	10	10	10	30
	max	40	60	80	80	116
C		30	50	70	55	90
L senza giunzioni - without joints	chiuso - closed	55	65	40	100	75
	aperto - open	300	350	220	750	550
L1 (1 giunzione - 1 joint)	chiuso - closed	110	130	80	200	150
	aperto - open	600	700	440	1500	1100
L2 (2 giunzioni - 2 joints)	chiuso - closed	165	195	120	300	225
	aperto - open	900	1050	660	2250	1650

DIMENSIONI - DIMENSION

CILINDRO - CYLINDER	SOFFIETTO SERIE	Senza giunzioni - Without joints		1 giunzione - with 1 joint		2 giunzioni - with 2 joints	
		WH cylinder	Max stroke	WH cylinder	Max stroke	WH cylinder	Max stroke
SERIE H - SERIE U	BELLOW SERIE						
H032	BLW60	66	245	126	490	186	735
H040	BLW83	78	285	148	570	218	855
H050	BLW83	80	285	150	570	220	855
H063	BLW83	80	285	150	570	220	855
H080	BLW83	83	285	149	570	219	855
H100	BLW106	64	180	96	360	144	540
H100	BLW106L	122	640	227	1290	332	1930
H125	BLW106	75	180	105	360	147	540
H125	BLW106L	122	640	227	1290	332	1930
U160	BLW106	85	150	108	350	153	525
U160	BLW106L	123	640	228	1290	333	1930
U160	BLW135	98	475	178	950	258	1425
U200	BLW135	std	475	178	950	258	1425

STAFFA FISSAGGIO VALVOLA

FIXING VALVE BRACKET

ACCESSORI DI FISSAGGIO - MOUNTING PARTS

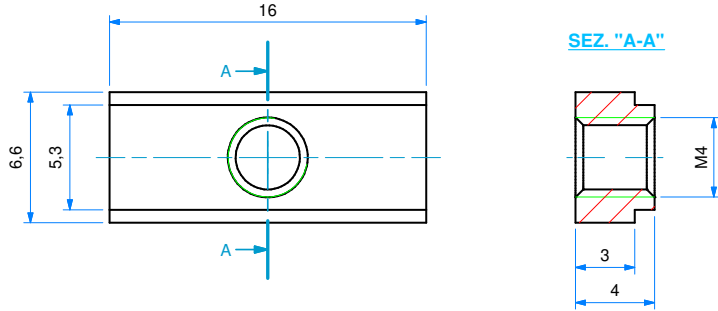

MATERIALE:
ACCIAIO ZINCATO
MATERIAL:
ZINC COATED STEEL

SERIE
H

STAFFA FISSAGGIO VALVOLA

FIXING VALVE BRACKET

SERIE
P

SERIE
A

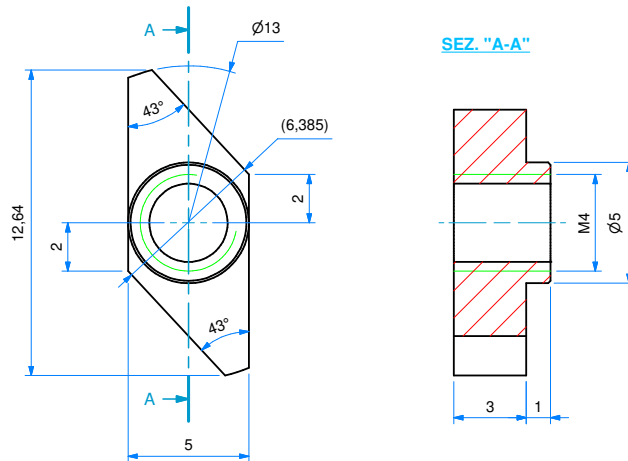

MATERIALE:
ACCIAIO ZINCATO
MATERIAL:
ZINC COATED STEEL

SERIE
W

ACCESSORI DI FISSAGGIO ISO 6432

ISO 6432 MOUNTING PARTS

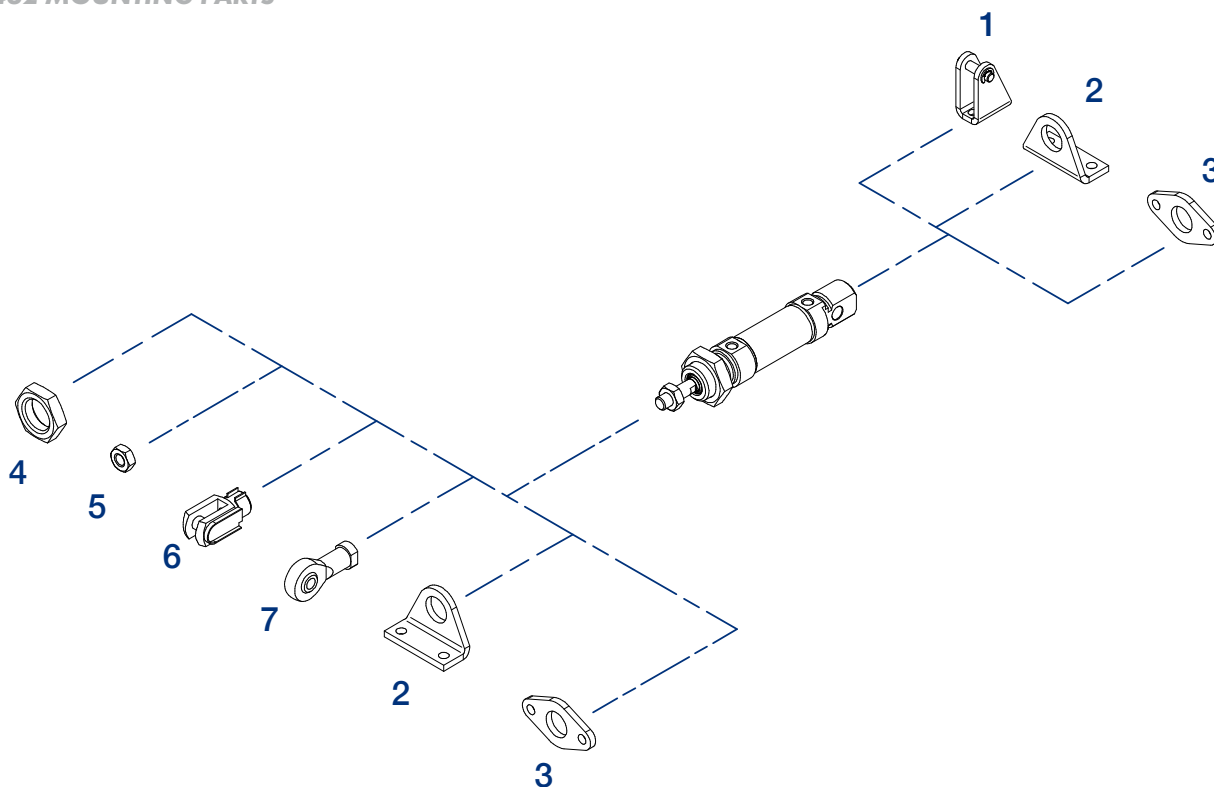

POS.	CODE	DESCRIZIONE-DESCRIPTION
1	MCFI ---,--- / MCFO ---	cerniera con perno - female hinge with pin
2	MPBI ---,---	pedino - foot mounting
3	MFI ---,---	flangia - flange
4	DAT ---,---	dado testata - nose nut
5	DA --x---	dado stelo - rod nut
6	FC --x---	forcella con clips - clevis with lockable pin
7	SSFI --x---	snodo sferico - rod eye

CERNIERA CON PERNO (MP3)

MCFI

MCFO

FEMALE HINGE WITH PIN (MP3)

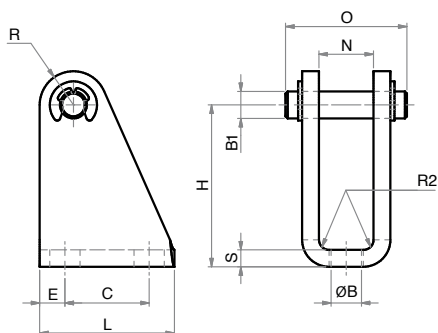

MATERIALE:
ACCIAIO ZINCATO
MATERIAL:
ZINC COATED STEEL

DIMENSIONI - DIMENSIONS

COD.	MCFI008.010	MCFI012.016	MCFI020.025	MCFO032	MCFO040
Ø mm	8 - 10	12 - 16	20 - 25	32	40
B	4,5	5,5	6,6	6,6	9
B1	4	6	8	10	12
C	12,5	15	20	24	30
E	3,75	5	6	5,5	7,5
H	24	27	30	35	40
L	20	25	32	35	45
N	8,1	12,1	16,1	16,1	18,1
O	18	24	31	31,3	35,5
R	5	7	10	12	12
R2	1,5	1,5	2	2	2
S	2,5	3	4	4	5

PIEDINO (MS3)

MPBI

FOOT MOUNTING (MS3)



MATERIALE: ACCIAIO ZINCATO
MATERIAL: ZINC COATED STEEL

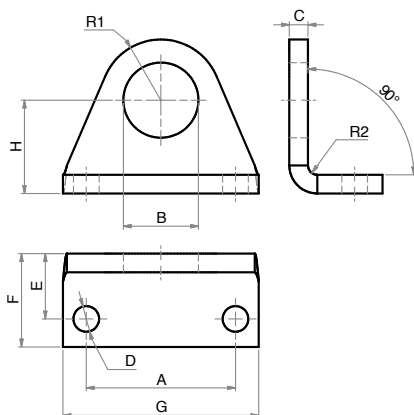

DIMENSIONI - DIMENSIONS

COD.	MPBI008.010	MPBI012.016	MPBI020.025
ø mm	8 - 10	12 - 16	20 - 25
A	25	32	40
B	12	16,1	22,1
C	3	4	5
D	4,5	5,5	6,6
E	11	14	17
F	16	20	25
G	35	42	54
H	16	20	25
R1	10	13	20
R2	1,5	2	2,5

FLANGIA (MF8)

MFI

FLANGE (MF8)



MATERIALE: ACCIAIO ZINCATO
MATERIAL: ZINC COATED STEEL

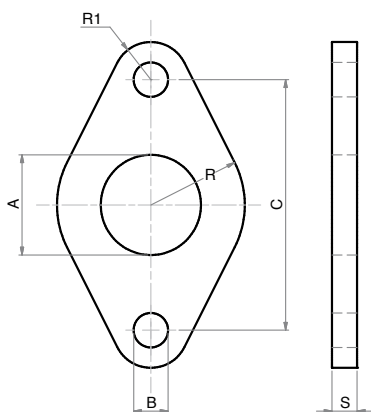

DIMENSIONI - DIMENSIONS

COD.	MFI008.010	MFI012.016	MFI020.025
ø mm	8 - 10	12 - 16	20 - 25
A	12	16	22
B	4,5	5,5	6,5
C	30	40	50
R	11	15	20
R1	5	6	8
S	3	4	5

DADO TESTATA (MR3)

DAT

NOSE NUT (MR3)



MATERIALE: ACCIAIO ZINCATO
MATERIAL: ZINC COATED STEEL

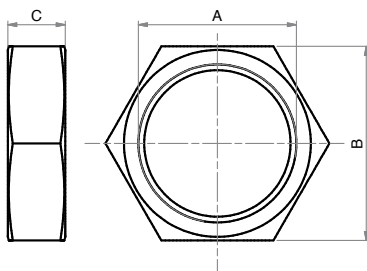

DIMENSIONI - DIMENSIONS

COD.	DAT008.010	DAT012.016	DAT020.025
A	M12x1,25	M16x1,5	M22x1,5
B	19	22	27
C	7	6	8

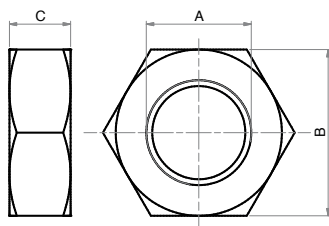
DADO STELO
PISTON ROD NUT

MATERIALE: ACCIAIO ZINCATO
MATERIAL: ZINC COATED STEEL

DIMENSIONI - DIMENSIONS

COD.	DA06x1	DA08x1,25	DA10x1,25
A	M6	M8	M10x1,25
B	10	13	17
C	4	5	6

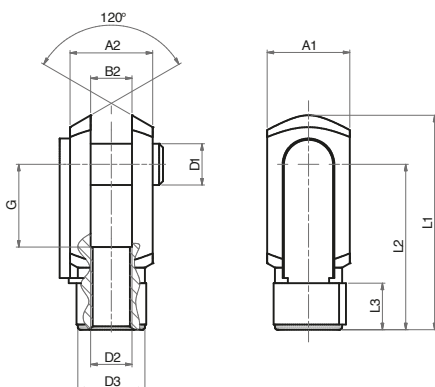
FORCELLA CON CLIPS
CLEVIS WITH LOCKABLE PIN

LA FORNITURA COMPRENDE:
n° 1 FORCELLA
n° 1 CLIPS
THE SUPPLY INCLUDES:
n° 1 FORK
n° 1 LOCKABLE PIN

MATERIALE: ACCIAIO ZINCATO
MATERIAL: ZINC COATED STEEL

DIMENSIONI - DIMENSIONS

COD.	FC04x0,7	FC06x1	FC08x1,25	FC10x1,25
A1	8	12	16	20
A2	8	12	16	20
B2	4	6	8	10
G	8	12	16	20
L1	21	31	42	52
L2	16	24	32	40
L3	6	9	12	15
ø D1	4	6	8	10
ø D2	M4x0,7	M6x1	M8x1,25	M10x1,25
ø D3	8	10	14	18

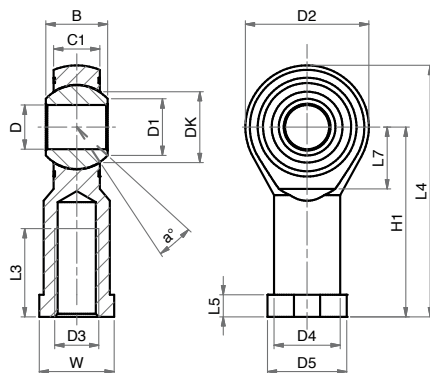
SNODO SFERICO FILETTO INTERNO
ROD EYE (INTERNAL THREAD)

MATERIALE:
CORPO IN ACCIAIO ZINCATO
SNODO IN ACCIAIO,
BRONZO E PTFE
MATERIAL:
BODY IN ZINC COATED STEEL
EYE IN STEEL, BRONZE
AND PTFE

DIMENSIONI - DIMENSIONS

COD.	SSF104x0,7	SSF106x1	SSF108x1,25	SSF110x1,25
α°	13	13	14	13
B	8	9	12	14
C1	6	6,75	9	10,5
D1	7,7	8,9	10,4	12,9
D2	18	20	24	28
D3	M4	M6	M8	M10x1,25
D4	9	10	12,5	15
D5	11	13	16	19
DK	11,11	12,7	15,87	19,05
D	5	6	8	10
H1	27	30	36	43
L3	10	12	16	20
L4	36	40	48	57
L5	4	5	5	6,5
L7	10	11	13	15
W	9	11	14	17



ACCESSORI DI FISSAGGIO CILINDRO TONDO

ROUND CYLINDER MOUNTING PARTS

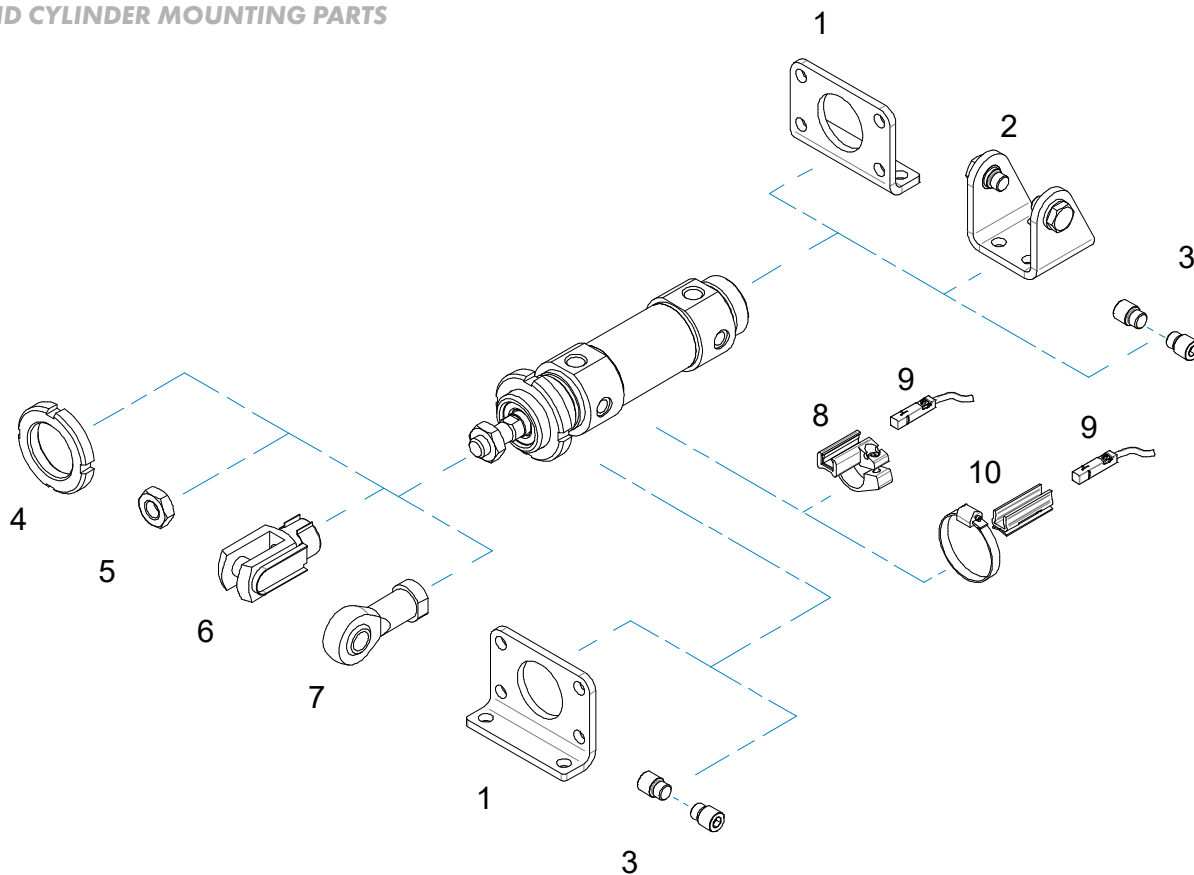

ACCESSORI DI FISSAGGIO - MOUNTING PARTS

SERIE

I

POS.	CODE	DESCRIZIONE - DESCRIPTION
1	MCFI---	cerniera con viti - hinge with screws
2	MPBI---	piedino flangia - foot flange
3	MPE---	perni - pivots
4	GHI---	ghiera - slotted nut
5	DA--x---	dado stelo - rod nut

POS.	CODE	DESCRIZIONE - DESCRIPTION
6	FC--x---	forcella con clips - clevis with lockable pin
7	SSFI--x---	snodo sferico - rod eye
8	36.TIRM---	adattatore sensore - sensor mounting
9	36.SEN---	sensore magnetico - magnetic sensor
10	36.TIRX---	adattatore sensore - sensor mounting

PIEDINO FLANGIA

MPBI

FOOT FLANGE

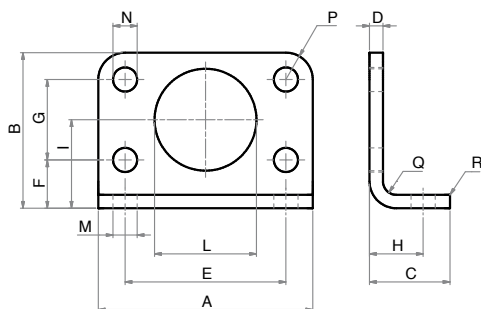

MATERIALE:
ACCIAIO ZINCATO
MATERIAL:
ZINC COATED STEEL

DIMENSIONI - DIMENSIONS

COD.	MPBI032	MPBI040	MPBI050	MPBI063
Ø mm	32	40	50	63
A	66	80	90	96
B	49	58	70	80
C	21	30	30	30
D	4	5	6	6
E	52	60	70	76
F	14	18	20	20
G	28	30	40	50
H	14	20	20	20
I	28	33	40	45
L	30	38	45	45
M	7	9	9	9
N	7	9	9	9
P	7	10	10	10
Q	4	5	6	6
R	2	2	2	2

SERIE

W

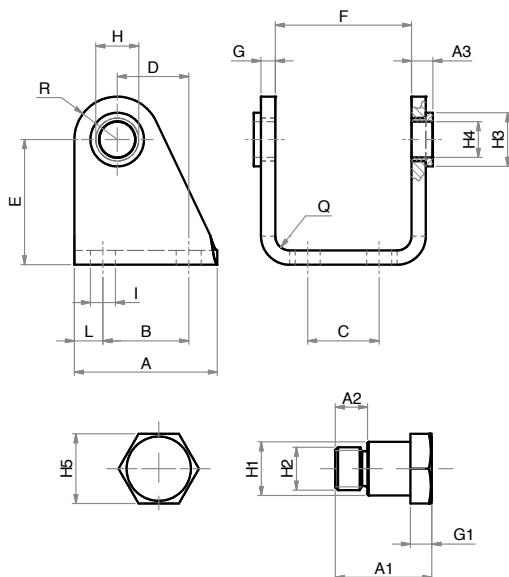
CERNIERA FEMMINA CON VITI
FEMALE HINGE WITH SCREWS

MATERIALE: ACCIAIO ZINCATO
MATERIAL: ZINC COATED STEEL

DIMENSIONI - DIMENSIONS

COD.	MCFI032	MCFI040	MCFI050	MCFI063
ø mm	32	40	50	63
A	40	50	54	65
A1	18	21,6	26,4	31,5
A2	6	7	9	13
A3	6	7	8,5	8,5
B	24	30	34	35
C	20	28	36	42
D	20	27	30	34
E	35	40	45	50
F	38,1	46,1	57,1	70,1
G	4	5	6	6
G1	4	5	6	6
H	12	15	18	20
H1	10	12	14	16
H2	M8x1	M10x1	M12x1,5	M14x1,5
H3	15	20	23	23
H4	10	12	14	16
H5	13	17	19	19
I	7	9	9	9
L	8	10	10	15
P	12	13	14	16
Q	4	5	6	6

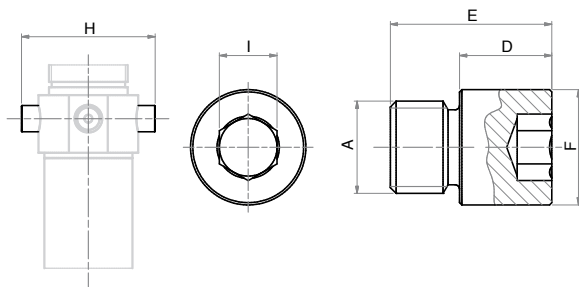
PERNI (COPPIA)
PIVOTS (2pcs)

MATERIALE: ACCIAIO ZINCATO
MATERIAL: ZINC COATED STEEL

DIMENSIONI - DIMENSIONS

COD.	MPE032	MPE040	MPE050	MPE063
ø mm	32	40	50	63
A	M8x1	M10x1	M12x1,5	M14x1,5
D	8	9,5	11	13
E	14	16,5	20	28
F	10	12	14	16
I	5	6	6	8
H	51	61	75	92

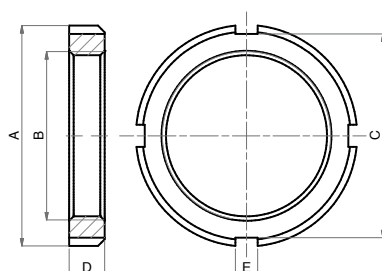
GHIERA
SLOTTED NUT

MATERIALE: ACCIAIO ZINCATO
MATERIAL: ZINC COATED STEEL

DIMENSIONI - DIMENSIONS

COD.	GHI032	GHI040	GHI050.63
ø mm	32	40	50 - 63
A	45	50	58
B	M30x1,5	M38x1,5	M45x1,5
C	40	46	52
D	7	8	9
E	5	5	6

DADO STELO

DA

PISTON ROD NUT

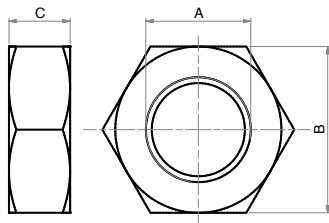

MATERIALE: ACCIAIO ZINCATO
MATERIAL: ZINC COATED STEEL

DIMENSIONI - DIMENSIONS

COD.	DA10x1,25	DA12x1,25	DA16x1,5
A	M10x1,25	M12x1,25	M16x1,5
B	17	19	24
C	6	7	8

FORCELLA CON CLIPS

FC

CLEVIS WITH LOCKABLE PIN

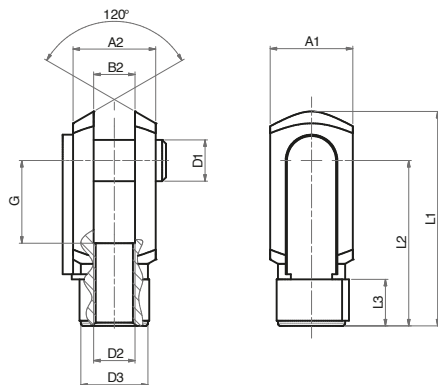

LA FORNITURA COMPRENDE:
n° 1 FORCELLA
n° 1 CLIPS
THE SUPPLY INCLUDES:
n° 1 FORK
n° 1 LOCKABLE PIN

MATERIALE: ACCIAIO ZINCATO
MATERIAL: ZINC COATED STEEL

DIMENSIONI - DIMENSIONS

COD.	FC10x1,25	FC12x1,25	FC16x1,5
A1	20	24	32
A2	20	24	32
B2	10	12	16
G	20	24	32
L1	52	62	83
L2	40	48	64
L3	15	18	24
ø D1	10	12	16
ø D2	M10x1,25	M12x1,25	M16x1,5
ø D3	18	20	26

SNODO SFERICO FILETTO INTERNO

SSFI

ROD EYE (INTERNAL THREAD)

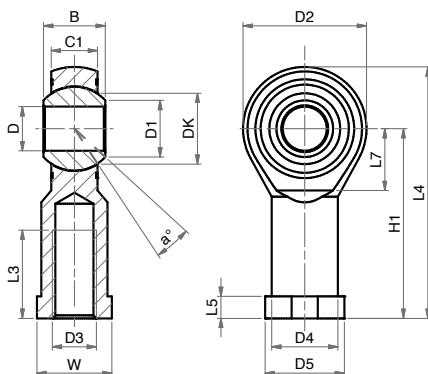

MATERIALE:
CORPO IN ACCIAIO ZINCATO
SNODO IN ACCIAIO,
BRONZO E PTFE
MATERIAL:
BODY IN ZINC COATED STEEL
EYE IN STEEL, BRONZE
AND PTFE

DIMENSIONI - DIMENSIONS

COD.	SSFI10x1,25	SSFI12x1,25	SSFI16x1,5
α°	13	13	15
B	14	16	21
C1	10,5	12	15
D1	12,9	15,4	19,3
D2	28	32	42
D3	M10x1,25	M12x1,25	M16x1,5
D4	15	17,5	22
D5	19	22	27
DK	19,05	22,22	28,57
D	10	12	16
H1	43	50	64
L3	20	22	28
L4	57	66	85
L5	6,5	6,5	8
L7	15	17	23
W	17	19	22

ACCESSORI DI FISSAGGIO ISO 15552 (UTILIZZABILI ANCHE PER CILINDRI SERIE P ISO 21287 E SERIE K)

ISO 15552 MOUNTING PARTS (ALSO SUITABLE FOR SERIE P ISO 21287 AND SERIE K CYLINDERS)

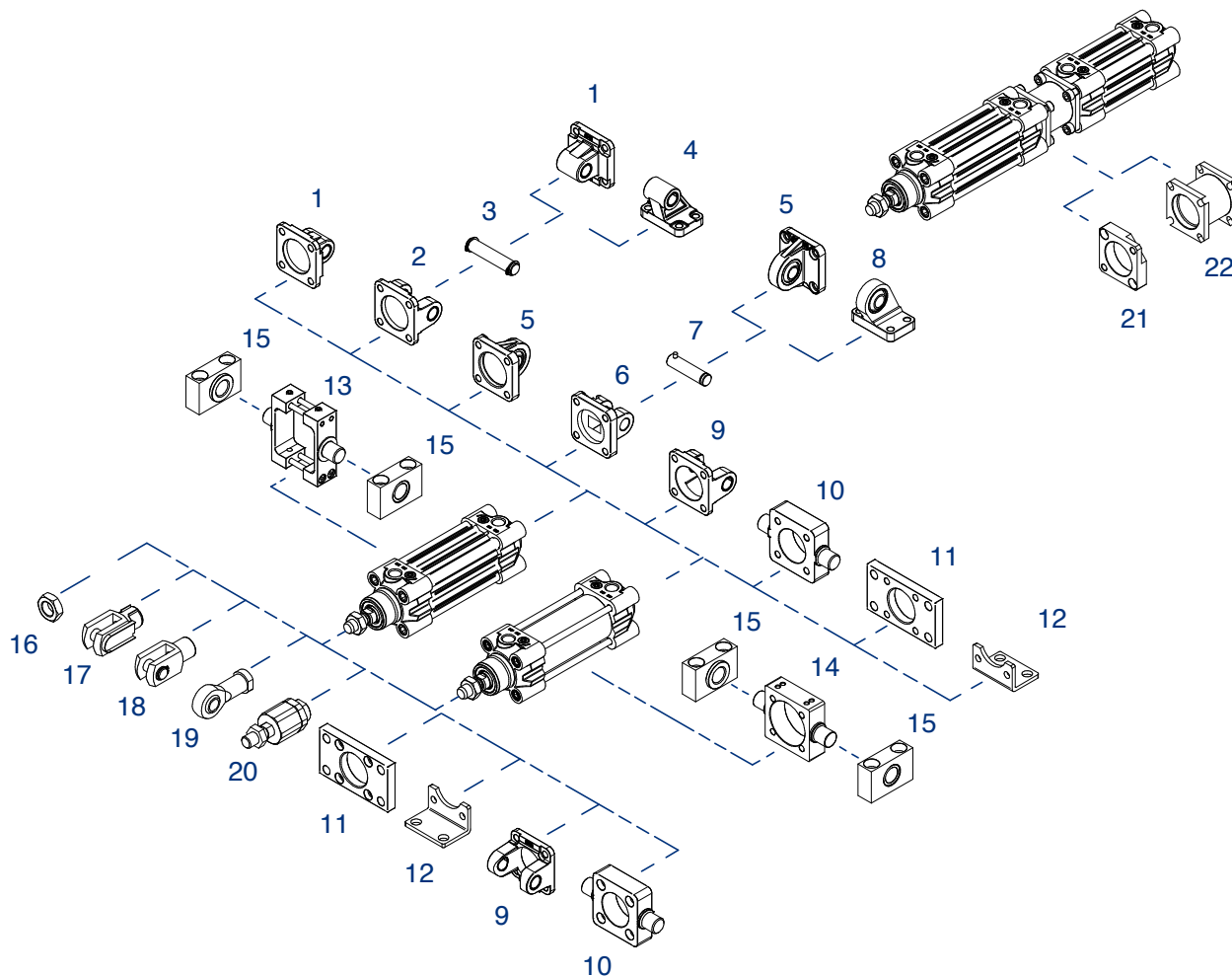

POS.	CODE	DESCRIZIONE-DESCRIPTION
1	CMI---	cerniera maschio iso - iso male hinge
2	CFI---	cerniera femmina iso - iso female hinge
3	PCF---	perno per cerniera - pin for hinge
4	ASI---	articolazione a squadra iso - iso square hinge
5	CMSI---	cerniera maschio snodata iso iso male hinge with ball joint
6	CFSI---	cerniera femmina stretta iso iso narrow female hinge
7	PCFS---	perno per cerniera stretta pin for narrow hinge
8	ASSI---	articolazione a squadra snodata iso square hinge with ball joint
9	CFI---F	cerniera femmina forata iso hollow iso female hinge
10	CIA---	cerniera anteriore-posteriore lamata front-rear hinge
11	FI---	flangia iso - iso flange
12	PBI---	pedino basso iso - iso foot mounting
13	CICP---	cerniera intermedia per tubo profilato intermediate hinge for profile tube
14	CICT---	cerniera intermedia per tiranti intermediate hinge for tie rod
15	SCI---	supporto cerniera intermedia support for intermediate hinge

POS.	CODE	DESCRIZIONE-DESCRIPTION
16	DA--x---	dado - nut
17	FC--x---	forcella con clips - clevis with lockable pin
18	FP--x---	forcella con perno - clevis with pin
19	SSFI--x---	snodo sferico - rod eye
20	SA--x---	snodo autoallineante - self-aligning joint
21	FLCI---	flangia cilindri contrapposti rear opposed cylinder flange
22	FLTI---	flangia cilindri tandem e più posizioni tandem and multi-position flange

Fissaggi forniti con viti - Mounting parts supplied with screws

POS.	CODE	DESCRIZIONE-DESCRIPTION
2+3	CFI--- S006	kit CFI+PCF - CFI+PCF kit
1+2+3	W--- S002	kit CMI+CFI+PCF - CMI+CFI+PCF kit
2+3+4	W--- S003	kit CFI+PCF+ASI - CFI+PCF+ASI kit
5+6+7	W--- S005	kit CMSI+CFSI+PCFS - CMSI+CFSI+PCFS kit
6+7+8	W--- S001	kit CFSI+PCFS+ASSI - CFSI+PCFS+ASSI kit

CERNIERA MASCHIO ISO (MP4)

CMI

ISO MALE HINGE (MP4)

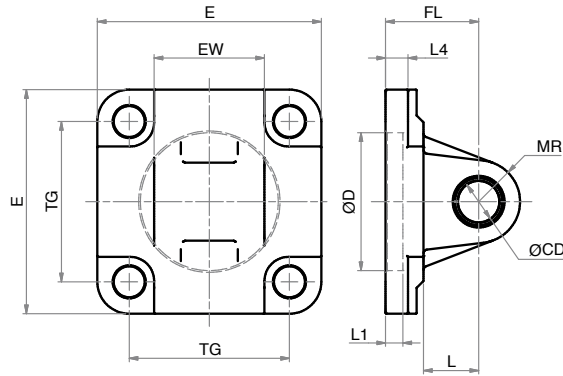

LA FORNITURA COMPRENDE:
n° 1 CERNIERA MASCHIO
n° 4 VITI
THE SUPPLY INCLUDES:
n° 1 MALE HINGE
n° 4 SCREWS

MATERIALE:
CORPO IN ALLUMINIO
BOCCOLA IN ACCIAIO E PTFE
MATERIAL:
BODY IN ALUMINIUM
BUSH IN STEEL AND PTFE

DIMENSIONI - DIMENSIONS

COD.	CMI032	CMI040	CMI050	CMI063	CMI080	CMI100	CMI125	CMI160	CMI200	CMI250	CMI320
Ø	32	40	50	63	80	100	125	160	200	250	320
EW	26	28	32	40	50	60	70	90	90	110	120
E	45	52	65	75	93	110	134	180	220	270	350
FL	22	25	27	32	36	41	50	55	60	70	80
L1	5	5	5	5	5	5	7	7	10	11	11
L4	5,5	5,5	6,5	6,5	10	10	10	10	11	17	22
L	13	16	16	21	22	27	30	35	35	45	50
MR	10	12	12	16	16	20	25	25	25	40	45
Ø CD	10	12	12	16	16	20	25	30	30	40	45
Ø D	30	35	40	45	45	55	60	65	75	90	110
TG	32,5	38	46,5	56,5	72	89	110	140	175	220	270

CERNIERA FEMMINA ISO (MP2)

CFI

CFI-F*

ISO FEMALE HINGE (MP2)

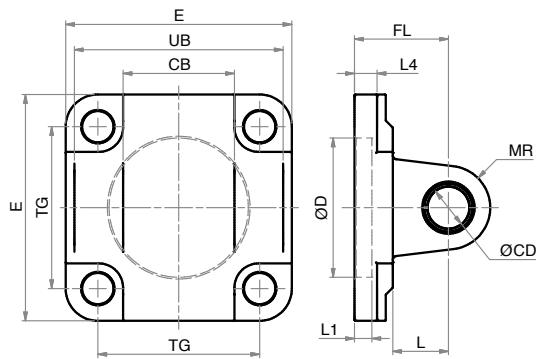

LA FORNITURA COMPRENDE:
n° 1 CERNIERA FEMMINA
n° 4 VITI
THE SUPPLY INCLUDES:
n° 1 FEMALE HINGE
n° 4 SCREWS

MATERIALE:
CORPO IN ALLUMINIO
BOCCOLA IN ACCIAIO E PTFE
MATERIAL:
BODY IN ALUMINIUM
BUSH IN STEEL AND PTFE

DIMENSIONI - DIMENSIONS

COD.	CFI032	CFI040	CFI050	CFI063	CFI080	CFI100	CFI125	CFI160	CFI200	CFI250	CFI320
Ø	32	40	50	63	80	100	125	160	200	250	320
CB	26	28	32	40	50	60	70	90	90	110	120
E	45	52	65	75	93	110	134	180	220	270	350
FL	22	25	27	32	36	41	50	55	60	70	80
L1	5	5	5	5	5	5	7	7	7	-	-
L4	5,5	5,5	6,5	6,5	10	10	10	10	10	17	22
L	13	16	16	21	22	27	30	35	35	45	50
MR	10	12	12	16	16	20	25	25	25	40	45
Ø CD	10	12	12	16	16	20	25	30	30	40	45
Ø D	30	35	40	45	45	55	60	65	75	90	110
TG	32,5	38	46,5	56,5	72	89	110	140	175	220	270
UB	45	52	60	70	90	110	130	170	170	200	220

*CFI---F dimensione foro centrale uguale alla quota ØD - *CFI---F dimension of the central hole are the same as ØD

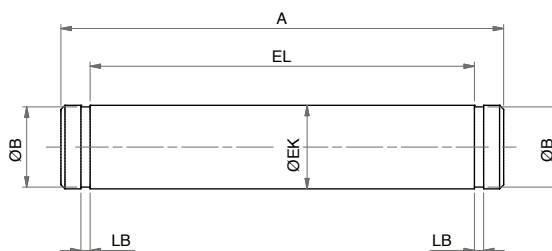
PERNO PER CERNIERA (AA4)
PIN FOR HINGE (AA4)

LA FORNITURA COMPRENDE:
 n°1 PERNO
 n°2 SEEGER
 THE SUPPLY INCLUDES:
 n°1 PIN
 n°2 RETAINING RING

MATERIALE:
 ACCIAIO ZINCATO
 MATERIAL:
 ZINC COATED STEEL

DIMENSIONI - DIMENSIONS

COD.	PCF032	PCF040	PCF050	PCF063	PCF080	PCF100	PCF125	PCF160.200	PCF250	PCF320
Ø	32	40	50	63	80	100	125	160-200	250	320
A	53	60	68	78	98	118	139	180	211	234
EL	46	53	61	71	91	111	132	172	202	222
LB	1,1	1,1	1,1	1,1	1,1	1,3	1,3	1,6	1,85	185
Ø B	9,6	11,5	11,5	15,2	15,2	19	23,9	28,6	37,5	42,5
Ø EK	10	12	12	16	16	20	25	30	40	45

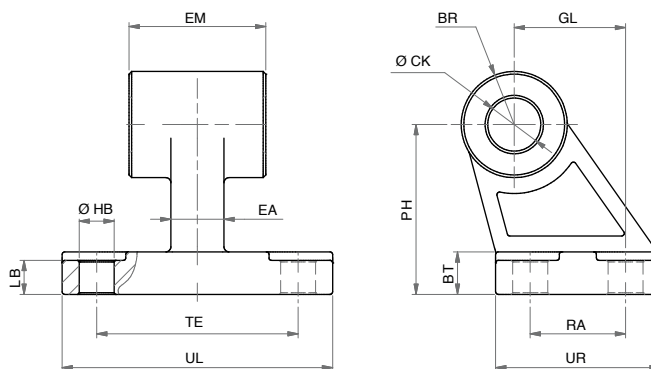
ARTICOLAZIONE A SQUADRA ISO (AB7)
ISO SQUARE HINGE (AB7)

LA FORNITURA COMPRENDE:
 n°1 ARTICOLAZIONE A SQUADRA
 THE SUPPLY INCLUDES:
 n°1 SQUARE HINGE

MATERIALE:
 CORPO IN ALLUMINIO
 BOCCOLA IN ACCIAIO E PTFE
 MATERIAL:
 BODY IN ALUMINIUM
 BUSH IN STEEL AND PTFE

DIMENSIONI - DIMENSIONS

COD.	ASI032	ASI040	ASI050	ASI063	ASI080	ASI100	ASI125	ASI160	ASI200	ASI250
Ø	32	40	50	63	80	100	125	160	200	250
BR	10	11	13	15	15	19	22,5	31,5	31,5	80
BT	8	10	12	14	14	17	20	25	30	35
Ø CK	10	12	12	16	16	20	25	30	30	40
EA	10	15	16	16	20	20	30	36	40	45
EM	26	28	32	40	50	60	70	90	90	110
GL	21	24	33	37	47	55	70	97	105	128
LB	6,4	8,4	10,4	12,4	11,5	14,5	16,8	21	26	30,5
Ø HB	6,6	6,6	9	9	11	11	14	14	18	22
PH	32	36	45	50	63	71	90	115	135	165
RA	18	22	30	35	40	50	60	88	90	110
TE	38	41	50	52	66	76	94	118	122	150
UL	51	54	65	67	86	96	124	156	162	200
UR	31	35	45	50	60	70	90	126	130	160

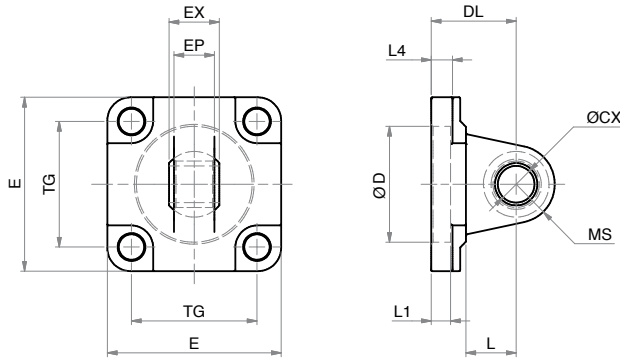
CERNIERA MASCHIO SNODATA ISO (MP6)
CMSI
ISO MALE HINGE WITH BALL JOINT (MP6)

LA FORNITURA COMPRENDE:
 n° 1 CERNIERA MASCHIO
 n° 4 VITI
 THE SUPPLY INCLUDES:
 n° 1 MALE HINGE
 n° 4 SCREWS

MATERIALE:
 CORPO IN ALLUMINIO
 SNODO IN ACCIAIO,
 BRONZO E PTFE
 MATERIAL:
 BODY IN ALUMINIUM
 EYE IN STEEL, BRONZE AND PTFE

DIMENSIONI - DIMENSIONS

COD.	CMSI032	CMSI040	CMSI050	CMSI063	CMSI080	CMSI100	CMSI125	CMSI160	CMSI200
Ø	32	40	50	63	80	100	125	160	200
DL	22	25	27	32	36	41	50	55	60
EP	10,5	12	15	15	18	18	25	28	28
EX	14	16	21	21	25	25	37	43	43
E	45	52	65	75	95	115	140	180	220
L1	7	7	7	7	9	9	9	7	10
L4	5,5	5,5	6,5	6,5	10	10	10	-	-
L	12	15	15	20	20	25	30	35	35
MS	16	18	21	23	28	30	40	44	47
ØCX	10	12	16	16	20	20	30	35	35
ØD	30	35	40	45	45	55	60	65	75
TG	32,5	38	46,5	56,5	72	89	110	140	175

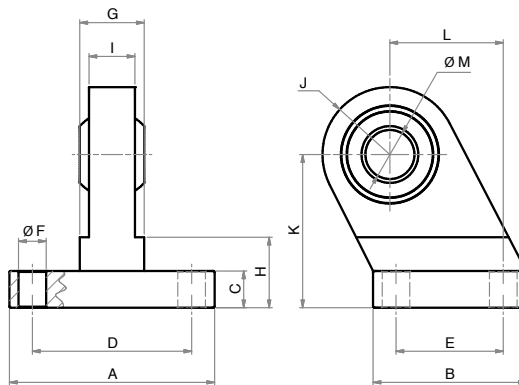
ARTICOLAZIONE A SQUADRA SNODATA
ASSI
ISO SQUARE HINGE WITH BALL JOINT

LA FORNITURA COMPRENDE:
 n° 1 ARTICOLAZIONE A SQUADRA
 THE SUPPLY INCLUDES:
 n° 1 SQUARE HINGE

MATERIALE:
 CORPO IN ALLUMINIO
 SNODO IN ACCIAIO,
 BRONZO E PTFE
 MATERIAL:
 BODY IN ALUMINIUM
 EYE IN STEEL, BRONZE AND PTFE

DIMENSIONI - DIMENSIONS

COD.	ASSI032	ASSI040	ASSI050	ASSI063	ASSI080	ASSI100
Ø	32	40	50	63	80	100
A	51	54	65	67	86	96
B	31	35	45	50	60	70
C	10	10	12	12	14	15
D	38	41	50	52	66	76
E	18	22	30	35	40	50
G	14	16	21	21	25	25
H	16	16	21	23	32	33
I	10,5	12	15	15	18	18
J	15	17	20	22	27	29
K	32	36	45	50	63	71
L	21	24	33	37	47	55
ØF	6,6	6,6	9	9	11	11
ØM	10	12	16	16	20	20

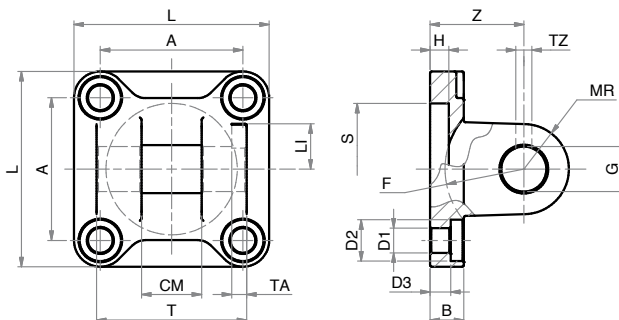
CERNIERA FEMMINA STRETTA ISO (AB6)
ISO NARROW FEMALE HINGE (AB6)

LA FORNITURA COMPRENDE:
 n° 1 CERNIERA FEMMINA
 n° 4 VITI
 THE SUPPLY INCLUDES:
 n° 1 FEMALE HINGE
 n° 4 SCREWS

MATERIALE: ALLUMINO
 MATERIAL: ALUMINIUM

DIMENSIONI - DIMENSIONS

COD.	CFSI032	CFSI040	CFSI050	CFSI063	CFSI080	CFSI100	CFSI125	CFSI160	CFSI200
ø	32	40	50	63	80	100	125	160	200
A	32,5	38	46,5	56,5	72	89	110	140	175
B	9	9	11	11	14	14	20	20	25
CM	14	16	21	21	25	25	37	43	43
D1	6,6	6,6	9	9	11	11	14	18	18
D2	11	11	15	15	18	18	20	26	26
D3	5,5	5,5	6,5	6,5	10	10	10	10	11
F min.	17	20	22	25	30	32	42	46	49
G	10	12	16	16	20	20	30	35	35
H	5	5	5	5	5	5	7	7	7
LI	11,5	12	14	14	16	16	24	26,5	26,5
L	45	52	65	75	95	115	140	180	220
MR	10	12	14	18	20	22	25	30	30
S	30	35	40	45	45	55	60	65	75
TA	3	4	4	4	4	4	6	6	6
TZ	3,3	4,3	4,3	4,3	4,3	6,3	6,3	6,3	6,3
T	34	40	45	51	65	75	97	122	122
Z	22	25	27	32	36	41	50	55	60

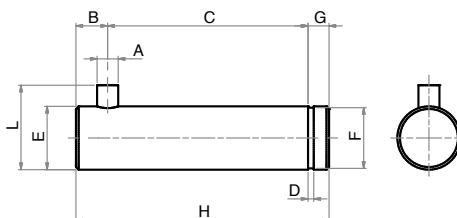
PERNO PER CERNIERA STRETTA (AA6)
PIN FOR NARROW HINGE (AA6)

LA FORNITURA COMPRENDE:
 n° 1 PERNO
 n° 1 SEEGER
 THE SUPPLY INCLUDES:
 n° 1 PIN
 n° 1 RETAINING RING

MATERIALE:
 ACCIAIO ZINCATO
 MATERIAL:
 ZINC COATED STEEL

DIMENSIONI - DIMENSIONS

COD.	PCFS032	PCFS040	PCFS050	PCFS063	PCFS080	PCFS100	PCFS125	PCFS160.200
ø	32	40	50	63	80	100	125	160
A	3	4	4	4	4	4	6	6
B	4,5	6	6	6	6	6	9	9
C	32,5	38	43	49	63	73	94	119
D	1,1	1,1	1,1	1,1	1,3	1,3	1,6	1,6
E	10	12	16	16	20	20	30	35
F	9,6	11,5	15,2	15,2	19	19	28,6	33
G	4	4	5	5	6	6	7	7
H	41	48	54	60	75	85	110	135
L	14	16	20	20	24	24	36	41

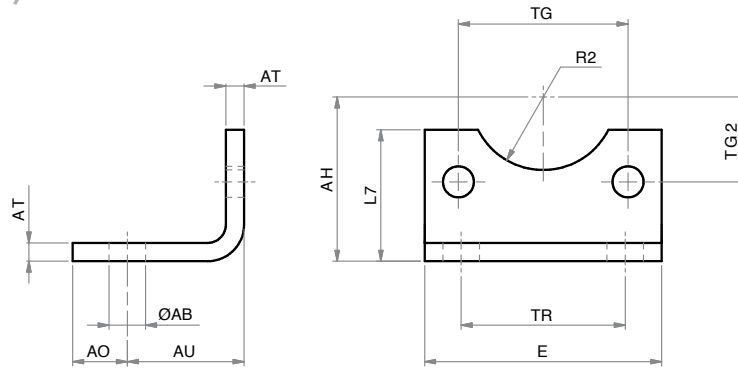
PIEDINO BASSO ISO (MS1)
PBI
ISO FOOT MOUNTING (MS1)

LA FORNITURA COMPRENDE:
 n° 1 PIEDINO
 n° 2 VITI
 THE SUPPLY INCLUDES:
 n° 1 FOOT MOUNTING
 n° 2 SCREWS

MATERIALE:
 ACCIAIO ZINCATO
 MATERIAL:
 ZINC COATED STEEL

DIMENSIONI - DIMENSIONS

COD.	PBI032	PBI040	PBI050	PBI063	PBI080	PBI100	PBI125	PBI160	PBI200
Ø	32	40	50	63	80	100	125	160	200
AH	32	36	45	50	63	71	90	115	135
AO	11	8	15	13	14	16	25	15	30
AT	4	4	5	5	6	6	8	10	12
AU	24	28	32	32	41	41	45	60	70
E	45	52	65	75	95	115	140	180	220
L7	30	30	36	35	47	53	70	100	109
Ø AB	7	10	10	10	12	14,5	16,5	18,5	24
R2	15	17,5	20	22,5	22,5	27,5	30	32,5	37,5
TG2	16,25	19	23,25	28,25	36	44,5	55	70	87,5
TG	32,5	38	46,5	56,5	72	89	110	140	175
TR	32	36	45	50	63	75	90	115	135

A richiesta - On request Ø 250-320

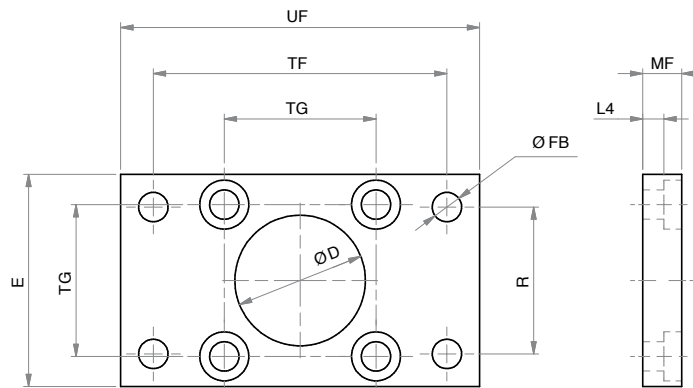
FLANGIA ISO (MF1 - MF2)
FI
ISO FLANGE (MF1 - MF2)

LA FORNITURA COMPRENDE:
 n° 1 FLANGIA
 n° 4 VITI
 THE SUPPLY INCLUDES:
 n° 1 FLANGE
 n° 4 SCREWS

MATERIALE:
 ACCIAIO ZINCATO
 MATERIAL:
 ZINC COATED STEEL

DIMENSIONI - DIMENSIONS

COD.	FI032	FI040	FI050	FI063	FI080	FI100	FI125	FI160	FI200	FI250	FI320
Ø	32	40	50	63	80	100	125	160	200	250	320
E	45	52	65	75	95	115	140	180	220	285	350
L4	5	5	6,5	6,5	9	9	10,5	9,5	12,5	10,5	15
MF	10	10	12	12	16	16	20	20	25	25	30
Ø D	30	35	40	45	45	55	60	65	75	90	110
Ø FB	7	9	9	9	12	14	16	18	22	26	33
R	32	36	45	50	63	75	90	115	135	165	200
TF	64	72	90	100	126	150	180	230	270	330	400
TG	32,5	38	46,5	56,5	72	89	110	140	175	220	270
UF	80	90	110	120	150	170	205	260	300	400	470

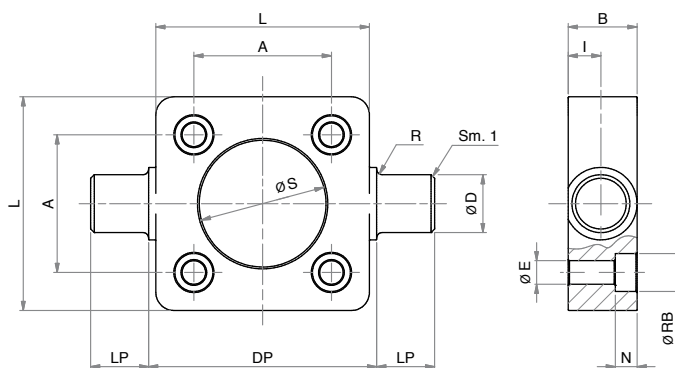
CERNIERA ANTERIORE-POSTERIORE LAMATA
FRONT-REAR HINGE

LA FORNITURA COMPRENDE:

n° 1 CERNIERA

n° 4 VITI

THE SUPPLY INCLUDES:

n° 1 HINGE

n° 4 SCREWS

MATERIALE:

ACCIAIO ZINCATO

MATERIAL:

ZINC COATED STEEL

DIMENSIONI - DIMENSIONS

COD.	CIA032	CIA040	CIA050	CIA063	CIA080	CIA100	CIA125
Ø	32	40	50	63	80	100	125
A	32,5	38	46,5	56,5	72	89	110
B	14	19	19	24	24	29	30
Ø D	12	16	16	20	20	25	25
DP	50	63	75	90	110	132	160
ØE	6,5	6,5	8,5	8,5	10,5	10,5	13,5
I	6,5	9	9	11,5	11,5	14	15
L	46	59	69	84	102	125	150
LP	12	16	16	20	20	25	25
N	6	6	8	8	10	10	12
R	1	1,5	1,6	1,6	1,6	2	2
Ø RB	10,5	10,5	13,5	13,5	16,5	16,5	20
Ø S	30	35	40	45	45	55	60

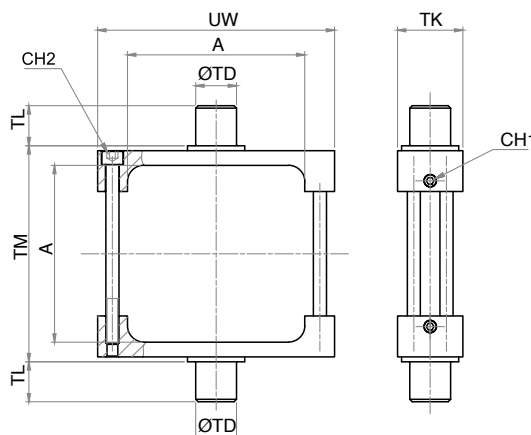
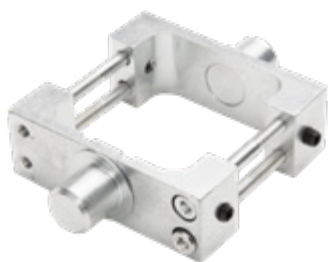
CERNIERA INTERMEDIA PER TUBO PROFILATO SERIE H
INTERMEDIATE HINGE FOR SERIE H PROFILE TUBE

LA FORNITURA COMPRENDE:

n° 1 PIEDINO

n° 2 VITI

THE SUPPLY INCLUDES:

n° 1 FOOT MOUNTING

n° 2 SCREWS

MATERIALE:

ACCIAIO ZINCATO

MATERIAL:

ZINC COATED STEEL

DIMENSIONI - DIMENSIONS

COD.	CICP032	CICP040	CICP050	CICP063	CICP080	CICP100	CICP125
Ø	32	40	50	63	80	100	125
A	45	51,8	60,7	72,2	91,2	108,2	135,3
CH1	3	3	3	3	3	4	4
CH2	3	4	5	5	5	6	6
Ø TD	12	16	16	20	20	25	25
TK	25	25	30	30	30	40	40
TL	11,5	16	16	20	20	24,5	24,5
TM	50	63	75	90	110	132	160
UW	65	75	95	105	130	145	176

Max. coppia serraggio [Nm]

Max. tightening torque [Nm]

8+1

8+2

18+2

28+2

28+2

40+2

CERNIERA INTERMEDIA PER TIRANTI (MT4)

CICT

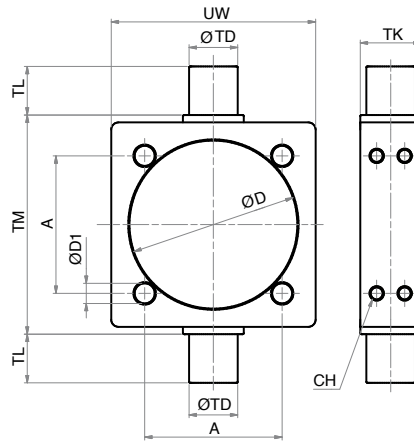
INTERMEDIATE HINGE FOR TIE RODS (MT4)

LA FORNITURA COMPRENDE:
n°1 CERNIERA INTERMEDIA
THE SUPPLY INCLUDES:
n°1 INTERMEDIATE HINGE

MATERIALE:
ACCIAIO ZINCATO
MATERIAL:
ZINC COATED STEEL

DIMENSIONI - DIMENSIONS

COD.	CICT032	CICT040	CICT050	CICT063	CICT080	CICT100	CICT125	CICT160*	CICT200*	CICT250**	CICT320**
Ø	32	40	50	63	80	100	125	160	200	250	320
A	32,5	38	46,5	56,5	72	89	110	140	175	220	270
CH	2,5	2,5	3	3	4	4	5	6	6	-	-
ØD1	6,25	6,25	8,25	8,25	10,25	10,25	12,25	16,5	16,5	20,25	24,25
ØD	37	46	56	69	87	107	133	172,5	213	264	338
ØTD	12	16	16	20	20	25	25	32	32	40	50
TK	15	20	20	25	25	30	32	40	40	50	70
TL	12	16	16	20	20	25	25	32	32	40	50
TM	50	63	75	90	110	132	160	200	250	320	400
UW	46	59	69	84	102	125	155	190	240	295	370

*Ø 160-200 cerniera intermedia fissata sui tiranti con 4+4 dadi - * Ø 160-200 intermediate hinge is fixed on tie rods with 4+4 nuts

**Ø 250-320 cerniera intermedia fissata sui tiranti con 4+4 dadi senza grani - ** Ø 250-320 intermediate hinge is fixed on tie rods with 4+4 nuts without screws

SUPPORTO PER CERNIERA INTERMEDIA (AT4)

SCI

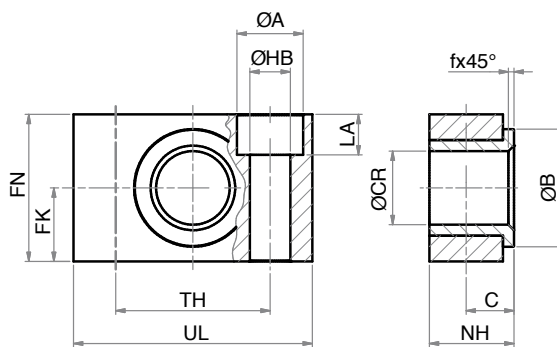
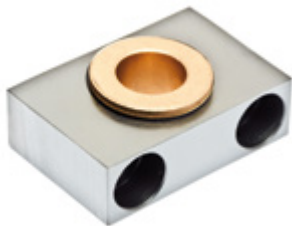
SUPPORT FOR INTERMEDIATE HINGE (AT4)

LA FORNITURA COMPRENDE:
N° 1 SUPPORTO
N° 2 VITI
THE SUPPLY INCLUDES:
n° 1 SUPPORT
n° 2 SCREWS

MATERIALE:
CORPO IN ALLUMINIO
BOCCOLA IN BRONZO
MATERIAL:
BODY IN ALUMINIUM
BUSH IN BRONZE

DIMENSIONI - DIMENSIONS

COD.	SCI032	SCI040.050	SCI063.080	SCI100.125	SCI160.200
Ø	32	40-50	63-80	100-125	160-200
C	10,5	12	13	16	22,5
FK	15	18	20	25	30
FN	30	36	40	50	60
f	1	1,6	1,6	2	2,5
LA	7	9	11	13	17
NH	18	21	23	28,5	40
ØA	11	15	18	20	26
ØB	22	28	32	39	45
ØCR	12	16	20	25	32
ØHB	6,6	9	11	14	18
TH	32	36	42	50	60
UL	46	55	65	75	92

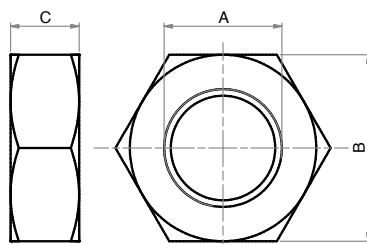
DADO STELO
PISTON ROD NUT

MATERIALE:
ACCIAIO ZINCATO
MATERIAL:
ZINC COATED STEEL

DIMENSIONI - DIMENSIONS

COD.	DA06x1	DA08x1,25	DA10x1,25	DA12x1,25	DA16x1,5	DA20x1,5	DA27x2	DA36x2	DA42x2	DA48x2
A	M6	M8	M10x1,25	M12x1,25	M16x1,5	M20x1,5	M27x2	M36x2	M42x2	M48x2
B	10	13	17	19	24	30	41	55	65	75
C	4	5	6	7	8	9	12	14	16	18

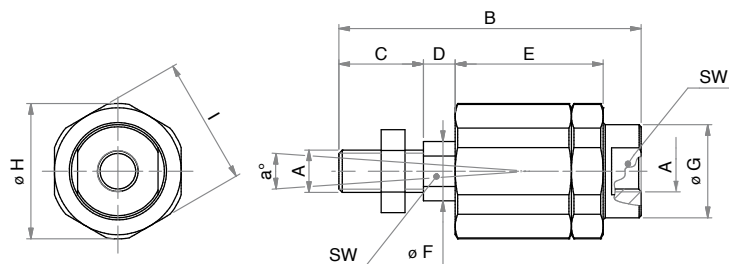
SNODO AUTOALLINEANTE
SELF-ALIGNING COUPLING

LA FORNITURA
COMPRENDE:
n° 1 SNODO
AUTOALLINEANTE
n° 1 DADO
THE SUPPLY INCLUDES:
n° 1 SELF ALIGNING
n° 1 NUT

MATERIALE:
ACCIAIO ZINCATO
MATERIAL:
ZINC COATED STEEL

DIMENSIONI - DIMENSIONS

COD.	SA06x1	SA08x1,25	SA10x1,25	SA12x1,25	SA16x1,5	SA20x1,5	SA27x2	SA36x2
A	M6x1	M8x1,25	M10x1,25	M12x1,25	M16x1,5	M20x1,5	M27x2	M36x2
a°	8	8	8	8	8	8	8	8
B	37	50	71	74,5	104	120	158	251
C	12	16	20	24	32	40	54	71
D	2,5	4	7	7,5	7	8	13	22
E	17,5	23,5	36	36	53	53	79	136
ø F	6	8	14	14	22	22	28	36
ø G	8,5	12,5	21,5	21,5	34	34	45	60
ø H	14,5	19	32	32	45	45	62	80
I	13	17	30	30	41	41	55	75
SW	5	7	12	12	19	19	24	32
SW1	7	10	19	19	30	30	41	55

SNODO SFERICO FILETTO INTERNO

SSFI

ROD EYE (INTERNAL THREAD)

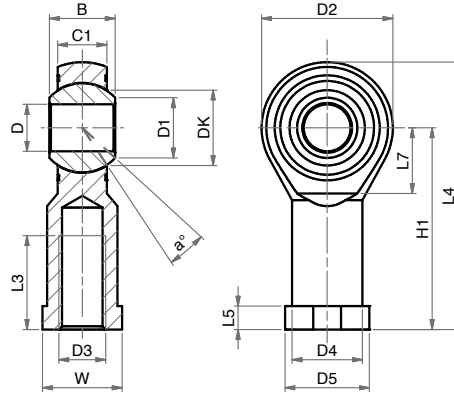

MATERIALE:
CORPO IN ACCIAIO ZINCATO
SNODO IN ACCIAIO,
BRONZO E PTFE
MATERIAL:
BODY IN ZINC COATED STEEL
EYE IN STEEL, BRONZE
AND PTFE

DIMENSIONI - DIMENSIONS

COD.	SSFI04x0,7	SSFI06x1	SSFI08x1,25	SSFI10x1,25	SSFI12x1,25	SSFI16x1,5	SSFI20x1,5	SSFI27x2	SSFI36x2	SSFI42x2	SSFI48x2
α°	13	13	14	13	13	15	14	17	16	16	14
B	8	9	12	14	16	21	25	37	43	49	60
C1	6	6,75	9	10,5	12	15	18	25	28	33	45
D1	7,7	8,9	10,4	12,9	15,4	19,3	24,3	34,8	37,7	45,1	56,6
D2	18	20	24	28	32	42	50	70	80	91	117
D3	M4	M6	M8	M10x1,25	M12x1,25	M16x1,5	M20x1,5	M27x2	M36x2	M42x2	M48x2
D4	9	10	12,5	15	17,5	22	27,5	40	46	53	65
D5	11	13	16	19	22	27	34	50	58	65	75
DK	11,11	12,7	15,87	19,05	22,22	28,57	34,92	50,8	57,15	66,6	82,5
ø D	5	6	8	10	12	16	20	30	35	40	50
H1	27	30	36	43	50	64	77	110	125	142	162
L3	10	12	16	20	22	28	33	51	56	60	65
L4	36	40	48	57	66	85	102	145	165	187	218
L5	4	5	5	6,5	6,5	8	10	15	17	19	23
L7	10	11	13	15	17	23	27	36	41	45	58
W	9	11	14	17	19	22	30	41	50	55	65

SNODO SFERICO FILETTO ESTERNO

SSFE

ROD EYE (EXTERNAL THREAD)

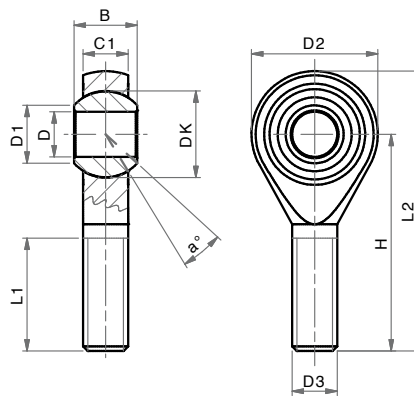

MATERIALE:
CORPO IN ACCIAIO ZINCATO
SNODO IN ACCIAIO,
BRONZO E PTFE
MATERIAL:
BODY IN ZINC COATED STEEL
EYE IN STEEL, BRONZE
AND PTFE

DIMENSIONI - DIMENSIONS

COD.	SSFE05x0,8	SSFE06x1	SSFE08x1,25	SSFE10x1,5	SSFE12x1,75	SSFE16x2	SSFE20x2,5
α°	13	13	14	13	13	15	14
B	8	9	12	14	16	21	25
C1	6	6,75	9	10,5	12	15	19
D1	7,7	8,9	10,4	12,9	15,4	19,3	24,3
D2	18	20	24	28	32	42	50
D3	M5	M6	M8	M10	M12	M16	M20
DK	11,11	12,7	15,87	19,05	22,22	28,57	34,52
ø D	5	6	8	10	12	16	20
H	33	36	42	48	54	66	78
L1	19	21	25	28	32	37	45
L2	42	46	54	62	70	87	103

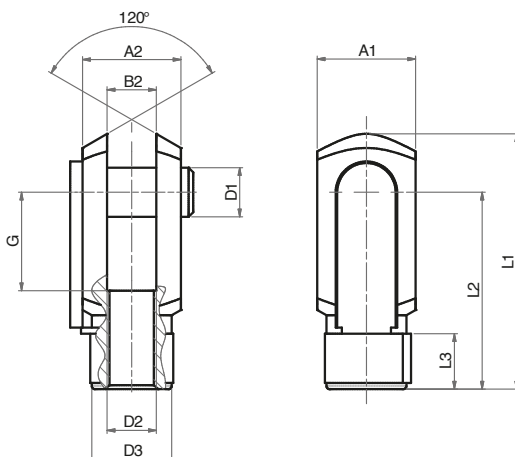
FORCELLA CON CLIPS
CLEVIS WITH LOCKABLE PIN

LA FORNITURA COMPRENDE:

n° 1 FORCELLA

n° 1 CLIPS

THE SUPPLY INCLUDES:

n° 1 FORK

n° 1 LOCKABLE PIN

MATERIALE:

ACCIAIO ZINCATO

MATERIAL:

ZINC COATED STEEL

DIMENSIONI - DIMENSIONS

COD.	FC04x0,7	FC06x1	FC08x1,25	FC10x1,25	FC12x1,25	FC16x1,5	FC20x1,5
A1	8	12	16	20	24	32	40
A2	8	12	16	20	24	32	40
B2	4	6	8	10	12	16	20
ø D1	4	6	8	10	12	16	20
D2	M4x0,7	M6x1	M8x1,25	M10x1,25	M12x1,25	M16x1,5	M20x1,5
ø D3	8	10	14	18	20	26	34
G	8	12	16	20	24	32	40
L1	21	31	42	52	62	83	105
L2	16	24	32	40	48	64	80
L3	6	9	12	15	18	24	30

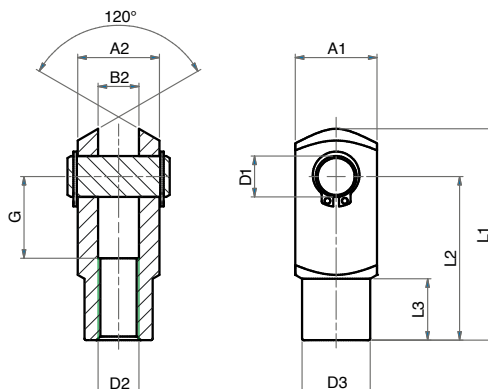
FORCELLA CON PERNO
CLEVIS WITH PIN

LA FORNITURA COMPRENDE:

n° 1 FORCELLA

n° 1 PERNO

n° 2 SEGER

THE SUPPLY INCLUDES:

n° 1 FORK

n° 1 PIN

n° RETAINING RING

MATERIALE:

ACCIAIO ZINCATO

MATERIAL:

ZINC COATED STEEL

DIMENSIONI - DIMENSIONS

COD.	FP06x1	FP08x1,25	FP10x1,25	FP12x1,25	FP16x1,5	FP20x1,5	FP27x2	FP36x2	FP42x2	FP48x2
A1	12	16	20	24	32	40	55	70	85	96
A2	12	16	20	24	32	40	55	70	85	96
B2	6	8	10	12	16	20	30	35	40	50
ø D1	6	8	10	12	16	20	30	35	40	50
D2	M6x1	M8x1,25	M10x1,25	M12x1,25	M16x1,5	M20x1,5	M27x2	M36x2	M42x2	M48x2
ø D3	10	14	18	20	26	34	48	60	70	82
G	12	16	20	24	32	40	54	72	84	96
L1	31	42	52	62	83	105	148	188	232	265
L2	24	32	40	48	64	80	110	144	168	192
L3	9	12	15	18	24	30	38	40	63,5	73

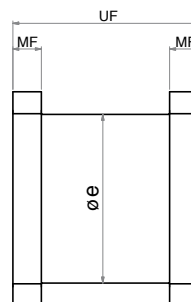
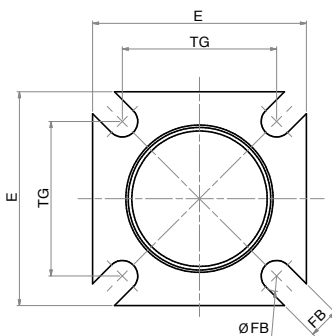
FLANGIA CILINDRI TANDEM E PIÙ POSIZIONI
FLTI
TANDEM AND MULTI-POSITION FLANGE

 MATERIALE: ALLUMINIO
 MATERIAL: ALUMINIUM

DIMENSIONI - DIMENSIONS

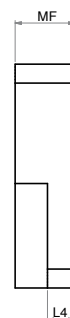
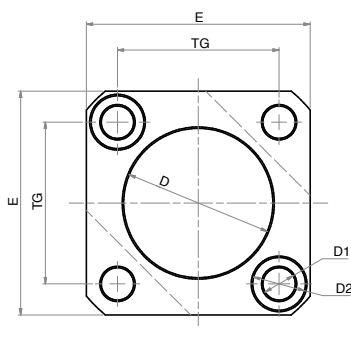
COD.	FLTI032	FLTI040	FLTI050	FLTI063	FLTI080	FLTI100	FLTI125	FLTI160	FLTI200	FLTI250	FLTI320
Ø	32	40	50	63	80	100	125	160	200	250	320
E	45	50	65	75	90	105	130	175	215	260	335
Ø e	35,5	42,5	51	65	84	102	127	160	205	240	320
FB	6,5	6,5	8,5	8,5	10,5	10,5	-	-	-	-	-
Ø FB	6,5	6,5	8,5	8,5	10,5	10,5	12,5	17	16	20	24
MF	6	6	9	10	10	10,5	10	18	15	20	20
TG	32,5	38	46	56,5	72	89	110	140	175	220	270
UF	39	45	52	53	65	77	93	112	132	152	182

FLANGIA CILINDRI CONTRAPPOSTI
FLCI
REAR OPPOSED CYLINDERS FLANGE

 MATERIALE: ALLUMINIO
 MATERIAL: ALUMINIUM

DIMENSIONI - DIMENSIONS

COD.	FLCI032	FLCI040	FLCI050	FLCI063	FLCI080	FLCI100	FLCI125	FLCI160	FLCI200	FLCI250	FLCI320
Ø	32	40	50	63	80	100	125	160	200	250	320
D	30	35	40	45	45	55	60	65	75	90	110
D1	6,5	6,5	8,5	8,5	10,5	10,5	12,5	16,5	16,5	20,5	24,5
D2	10,6	10,6	13,5	13,5	16,5	16,5	18,5	24,5	24,5	30	36
E	45	50	65	75	90	105	130	180	215	260	340
L4	5,5	5,5	7,5	7,5	9	10,5	15	12,5	12,5	15	20
MF	12	12	16	16	20	20	30	25	25	30	40
TG	32,5	38	46,5	56,5	72	89	110	140	175	220	270

ACCESSORI DI FISSAGGIO UNITOP

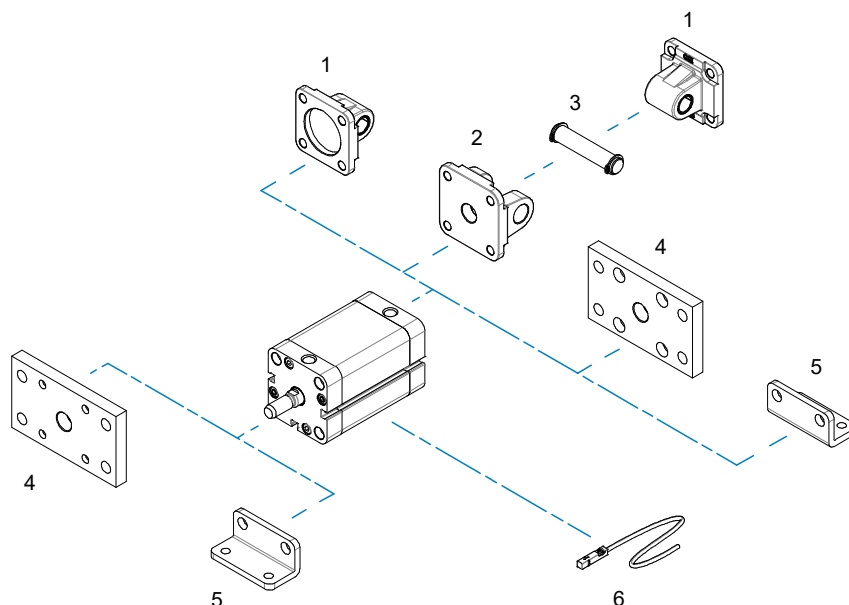
UNITOP MOUNTING PARTS



POS.	CODE	DESCRIZIONE - DESCRIPTION
1	CMI---	cerniera maschio - <i>male hinge</i>
2	CFU---	cerniera femmina unitop - <i>unitop female hinge</i>
3	PCF---	perno per cerniera - <i>pin for hinge</i>
4	FU---	flangia unitop - <i>unitop flange</i>
5	PBU---	pedino basso unitop - <i>unitop foot mounting</i>
6	36.SEN---	sensore magnetico - <i>magnetic sensor</i>

Fissaggi forniti con viti - *Mounting parts supplied with screws*

CERNIERA MASCHIO

CMI

MALE HINGE

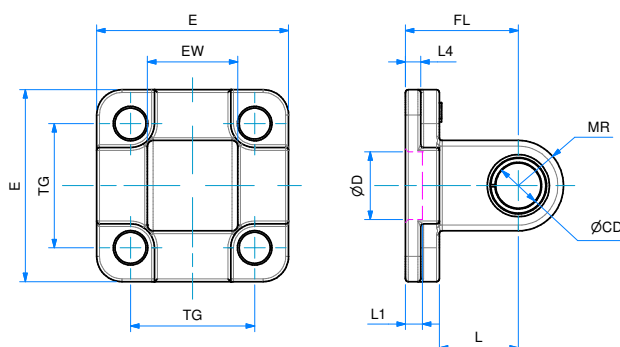

DIMENSIONI - DIMENSIONS

COD.	CMI016	CMI020	CMI025
Ø	16	20	25
E	27	34	38
EW	12	16	16
TG	18	22	26
FL	16	20	20
L1	/	3	3
L	10	14	14
L4	3,4	2,7	2,7
ØD	/	12	12
ØCD	6	8	8
MR	6	8	8

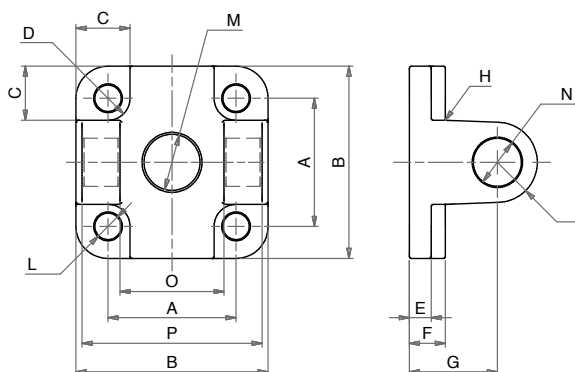
CERNIERA FEMMINA UNITOP
CFU

LA FORNITURA COMPRENDE:
 n° 1 CERNIERA FEMMINA
 n° 4 VITI
 THE SUPPLY INCLUDES:
 n° 1 FEMALE HINGE
 n° 4 SCREWS

MATERIALE: ALLUMINIO
 MATERIAL: ALUMINIUM

DIMENSIONI - DIMENSIONS

COD.	CFU032	CFU040	CFU050	CFU063	CFU080	CFU100
ø	32	40	50	63	80	100
A	32	42	50	62	82	103
B	48	58	66	83	102	123
C	13,5	13,5	15,5	18	19	19
D	5,5	5,5	7,5	7,5	9	9
E	5,5	5,5	6,5	6,5	10	10
F	9	9	11	11	13	15
G	22	25	27	32	36	41
H	2,5	2,5	2,5	4	4	4
I	10	12,5	12,5	15	15	20
L	6,6	6,6	9	9	11	11
M	14	14	18	18	23	28
N	12	14	14	18	18	23
O	26	28	32	40	50	60
P	45	52	60	70	90	110
Q	10	12	12	16	16	20

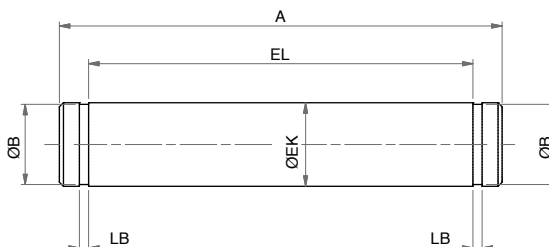
PERNO PER CERNIERA (AA4)
PCF
PIN FOR HINGE (AA4)

LA FORNITURA COMPRENDE:
 n° 1 PERNO
 n° 2 SEEGER
 THE SUPPLY INCLUDES:
 n° 1 PIN
 n° 2 RETAINING RING

MATERIALE:
 ACCIAIO ZINCATO
 MATERIAL:
 ZINC COATED STEEL

DIMENSIONI - DIMENSIONS

COD.	PCF032	PCF040	PCF050	PCF063	PCF080	PCF100	PCF125	PCF160.200
ø	32	40	50	63	80	100	125	160-200
A	53	60	68	78	98	118	139	180
EL	46	53	61	71	91	111	132	172
LB	1,1	1,1	1,1	1,1	1,1	1,3	1,3	1,6
ø B	9,6	11,5	11,5	15,2	15,2	19	23,9	28,6
ø EK	10	12	12	16	16	20	25	30

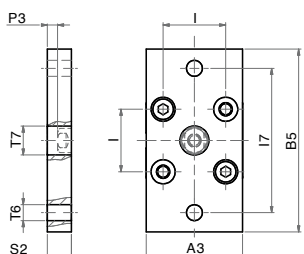
FLANGIA UNITOP
UNITOP MOUNTING

LA FORNITURA
COMPRENDE:
n° 1 FLANGIA
n° 2 VITI
THE SUPPLY INCLU-
DES:
n° 1 FLANGE
n° 2 SCREWS

Ø016 - Ø020 - Ø025

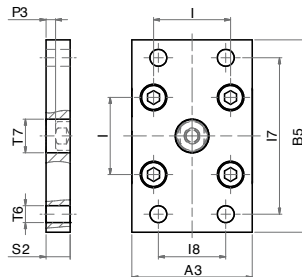

LA FORNITURA COM-
PRENDE: n° 1 FLANGIA
n° 4 VITI
THE SUPPLY INCLUDES:
n° 1 FLANGE
n° 4 SCREWS

MATERIALE:
ACCIAIO ZINCATO
MATERIAL:
ZINC COATED STEEL

Ø032 - Ø040 - Ø050 - Ø063 - Ø080 - Ø100

DIMENSIONI - DIMENSIONS

COD.	FI016	FI020	FI025	FU032	FU040	FU050	FU063	FU080	FU100
Ø	016	020	025	032	040	050	063	080	100
A3	29	36	40	50	60	68	87	107	128
B5	55	70	76	80	102	110	130	160	190
I7	43	55	60	65	82	90	110	135	163
I8	-	-	-	32	36	45	50	63	75
I	18	22	26	32	42	50	62	82	103
Ø T6	5,5	6,5	6,5	7	9	9	9	12	14
Ø T7	10	12	12	14	14	18	18	23	28
P3	5,5	5,5	4,5	4	3,5	4,5	7,5	7	5
S2	10	10	10	10	10	12	15	15	15

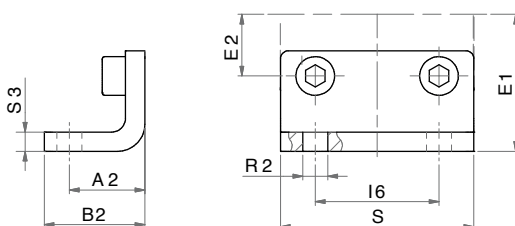
PIEDINO BASSO UNITOP
UNITOP FOOT MOUNTING

LA FORNITURA
COMPRENDE:
n° 1 PIEDINI
n° 2 VITI
THE SUPPLY INCLUDES:
n° 1 FOOT MOUNTING
n° 2 SCREWS

MATERIALE:
ACCIAIO ZINCATO
MATERIAL:
ZINC COATED STEEL

DIMENSIONI - DIMENSIONS

COD.	PBI016	PBI020	PBI025	PBU032	PBU040	PBU050	PBU063	PBU080	PBU100
Ø	016	020	025	032	040	050	063	080	100
A2	13	16	16	18	20	24	27	30	33
B2	17,5	22	22	26	28	32	39	42	45
E1	22	27	30	32	42,5	47	59,5	62,5	78
E2	9	11	13	16	21	25	31	41	51,5
I6	18	22	26	32	42	50	62	82	103
Ø R2	5,5	6,5	6,5	6,5	9	9	11	11	13,5
S	30	36	40	50	60	68	84	102	123
S3	3	4	4	5	5	6	6	8	8

ACCESSORI DI FISSAGGIO CILINDRO CORSA BREVE (SERIE F)

SHORT STROKE CYLINDER MOUNTING PARTS (SERIE F)

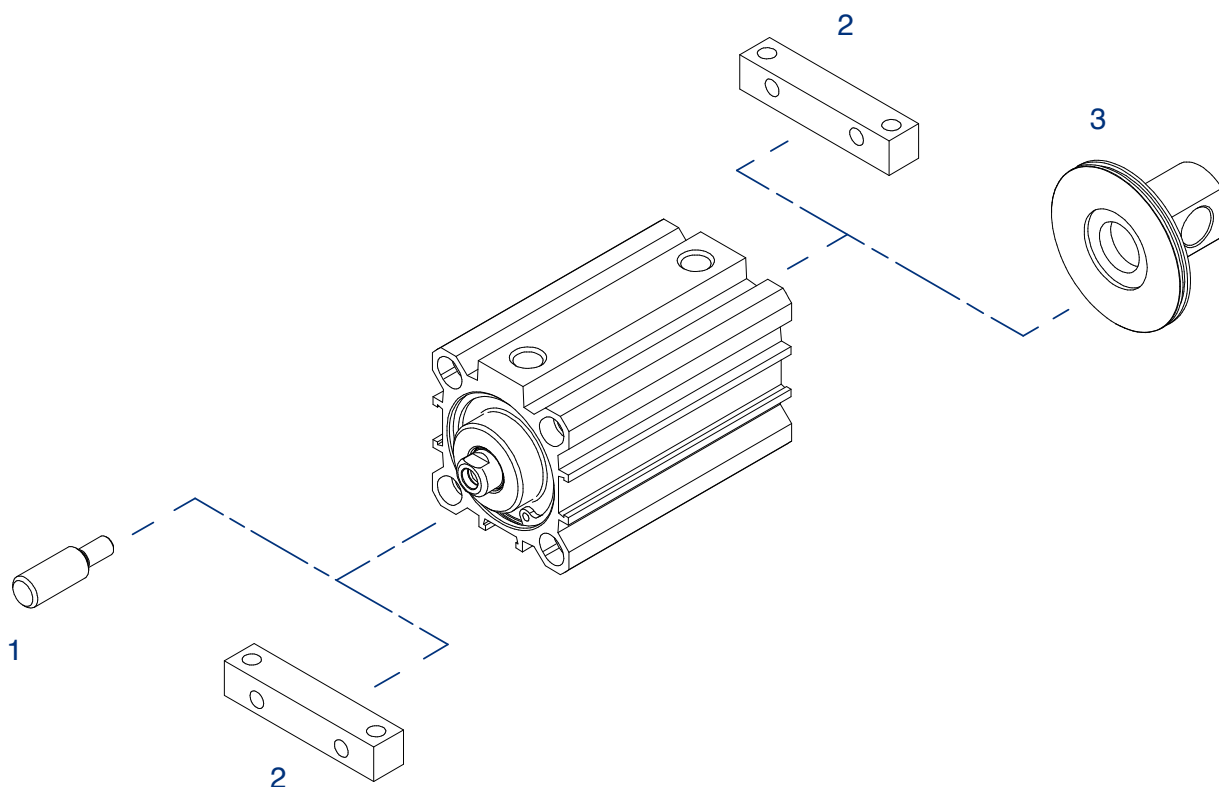

ACCESSORI DI FISSAGGIO - MOUNTING PARTS

SERIE
F

POS.	CODE	DESCRIZIONE-DESCRIPTION
1	NP---	niplo - nipples
2	FPD---	pieдино - foot mounting
3	FCP---	cerniera maschio - male hinge

NIPPLIO

NP

NIPPLE

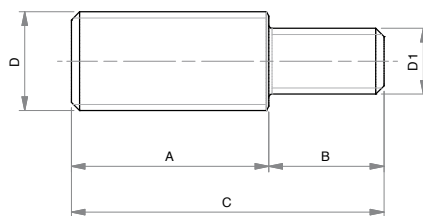

MATERIALE:
ACCIAIO INOX
MATERIAL:
STAINLESS STEEL

DIMENSIONI - DIMENSIONS

COD.	NP6.3	NP6.4	NP8.5	NP10.6	NP12.8	NP16.8	NP16.10	NP20.12
A	16	15	20	22	24	32	32	40
B	6,5	8	10	12	14	14	15	20
C	22,5	23	30	34	38	46	47	60
D	M6x1	M6x1	M8x1,25	M10x1,25	M12x1,25	M16x1,5	M16x1,5	M20x1,5
D1	M3	M4	M5	M6	M8	M8	M10	M12

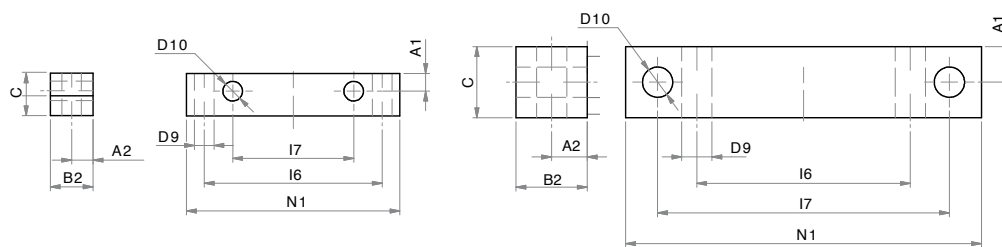
PIEDINO
FOOT MOUNTING

Ø016 - Ø020 - Ø025 - Ø032 - Ø040 - Ø050 - Ø063

Ø080 - Ø100

 MATERIALE: ALLUMINIO ANODIZZATO
 MATERIAL: ANODIZED ALUMINIUM

DIMENSIONI - DIMENSIONS

COD.	FPD016	FPD020	FPD025	FPD032	FPD040	FPD050	FPD063	FPD080	FPD100
Ø	016	020	025	032	040	050	063	080	100
A1	3	5	6	5	5,5	7,5	6	9	9,5
A2	5	5	6	6	6	7,5	7,5	10	10
B2	10	10	12	12	12	15	15	20	20
C	10	10	12	12	12	15	15	20	20
E1	17	18	20	24	27,5	32,5	40	50	62
F2	5	5	7,5	5	5	5	7,5	20	22
I6	30	40	45	50	60	70	85	60	80
I7	20	25,5	28	34	42	50	62	82	103
N1	40	50	60	60	70	80	100	100	124
Ø D10	3,5	5,5	5,5	5,5	5,5	5,5	8,5	8,5	10,5
Ø D9	3,5	5,5	5,5	5,5	5,5	6,5	8,5	8,5	10,5

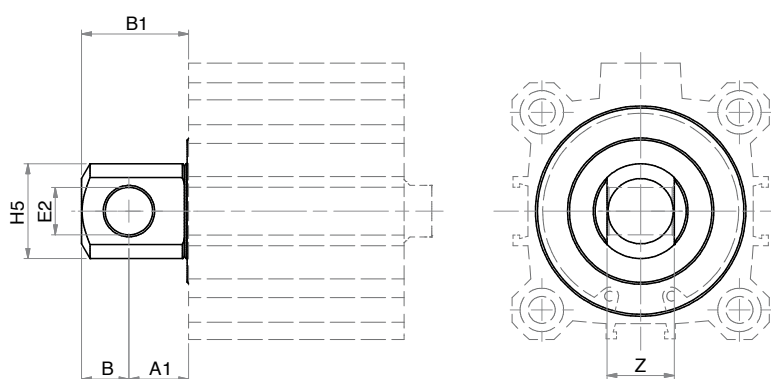
CERNIERA MASCHIO
MALE HINGE

 MATERIALE: ALLUMINIO ANODIZZATO
 MATERIAL: ANODIZED ALUMINIUM

DIMENSIONI - DIMENSIONS

COD.	FCP016	FCP020	FCP025	FCP032	FCP040	FCP050	FCP063	FCP080	FCP100
Ø	016	020	025	032	040	050	063	080	100
A1	8	10	10	13	15	15	19	19	23
B1	14	18	18	23	27	27	35	35	43
B	6	8	8	10	12	12	16	16	20
Ø E2	6	8	8	10	12	12	16	16	20
Ø H5	12	16	16	20	24	24	32	32	40
Z	7	9	9	14	16	17	22	22	26

UNITÀ DI GUIDA IN ACCIAIO INOX

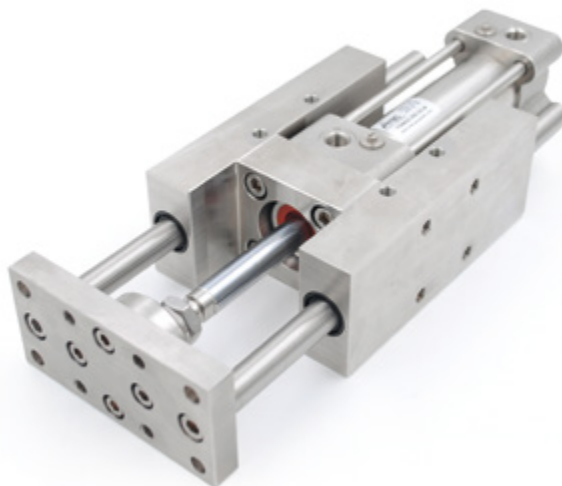
STAINLESS STEEL GUIDE UNIT



CARATTERISTICHE COSTRUTTIVE - CONSTRUCTIVE CHARACTERISTICS

- | | | |
|---|--------------------------------------|---|
| ① | Piastra - Plate | acciaio inox AISI 304 o AISI 316 - AISI 304 or AISI 316 stainless steel |
| ② | Ghiera - Slotted nut | acciaio inox AISI 304 o AISI 316 - AISI 304 or AISI 316 stainless steel |
| ③ | Giunto - Coupling | acciaio inox AISI 304 o AISI 316 - AISI 304 or AISI 316 stainless steel |
| ④ | Boccola guida - Slide bearing | PTFE - PTFE |
| ⑤ | Stelo - Rod | acciaio inox AISI 304 o AISI 316 - AISI 304 or AISI 316 stainless steel |
| ⑥ | Corpo - Body | acciaio inox AISI 304 o AISI 316 - AISI 304 or AISI 316 stainless steel |
| ⑦ | Raschiastelo - Scraper | Silicone - Silicone |

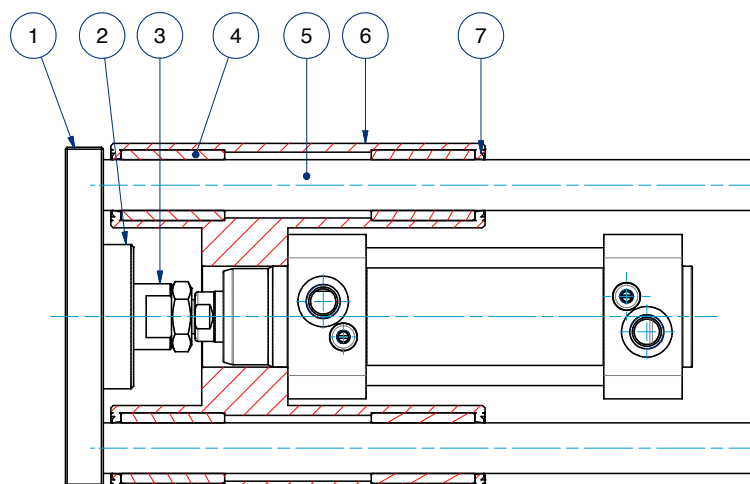

CHIAVE DI CODIFICA

KEY CODE

G H X 4 0 5 0 . 1 0 0 . S

	ALESAGGIO - BORE (Ø) 016-020-025-032-040 050-063-080-100	CORSA - STROKE (mm) 050-100-160-200 250-320-400-500 600-700-800-900-1000	GIUNTO - COUPLING S giunto corto short coupling L giunto lungo long coupling
VERSIONE - VERSION			
HX4	tipo H inox AISI 304 con boccole in PTFE H type AISI 304 SS with PTFE bushes		
HX6	tipo H inox AISI 316 con boccole in PTFE H type AISI 316 SS with PTFE bushes		
SERIE - SERIES			
G	unità di guida guide unit		

DIAGRAMMA CARICO AMMISSIBILE

GHX4

GHX6

ALLOWABLE LOAD

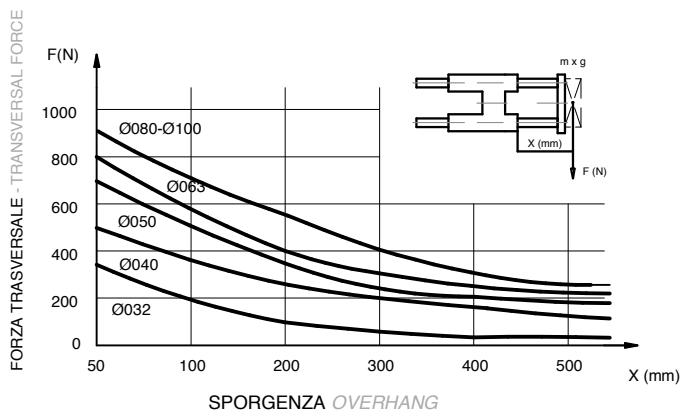
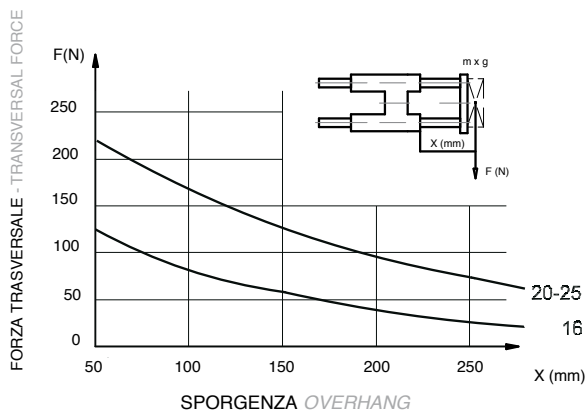

DIMENSIONI

DIMENSIONS

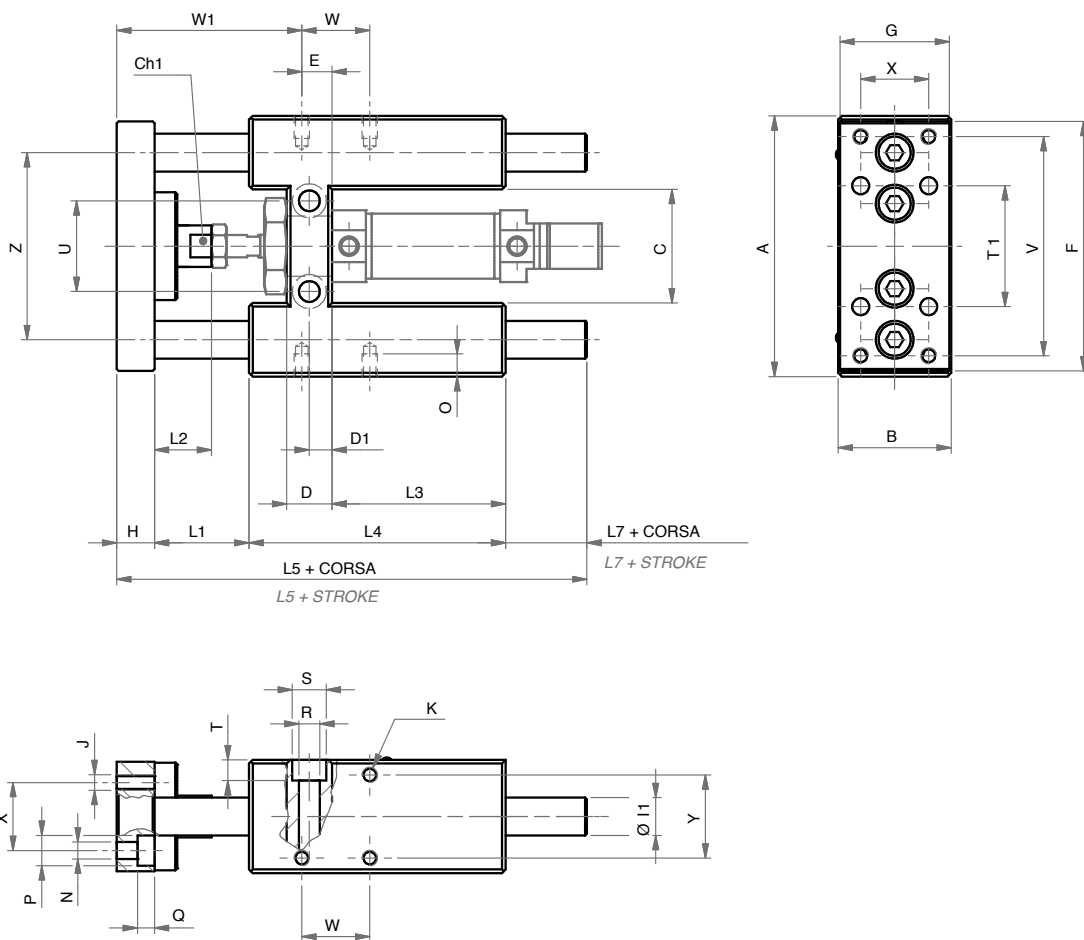

GIUNTO LUNGO - LONG COUPLING

Ø	L1	L2	W1
16	25	18	49
20 - 25	25	40	72

GIUNTO CORTO - SHORT COUPLING

Ø	A	B	C	Ch1	D	D1	E	F	G	H	Ø11	Ø12	J	K	L1	L2	L3	L4
16	69	30	30	8	12	6	8	66	29	10	10	8	M4	M4	22	15	46	68
20 - 25	79	34	37	12	17	8,5	15	78	32	12	12	10	M5	M6	3	18	58	108

Ø	L5	L7	N	O	P	Q	R	S	T	T1	U	V	W	W1	X	Y	Z
16	121,5	21,5	4,5	6	8	4,5	5,5	9	5,5	32	30	58	18	46	18	22	49,5
20 - 25	144	21	5,5	9	10	7,5	6,5	11	6	38	37	68	32,5	50	20	23	58

DIMENSIONI

GHX4

GHX6

DIMENSIONS

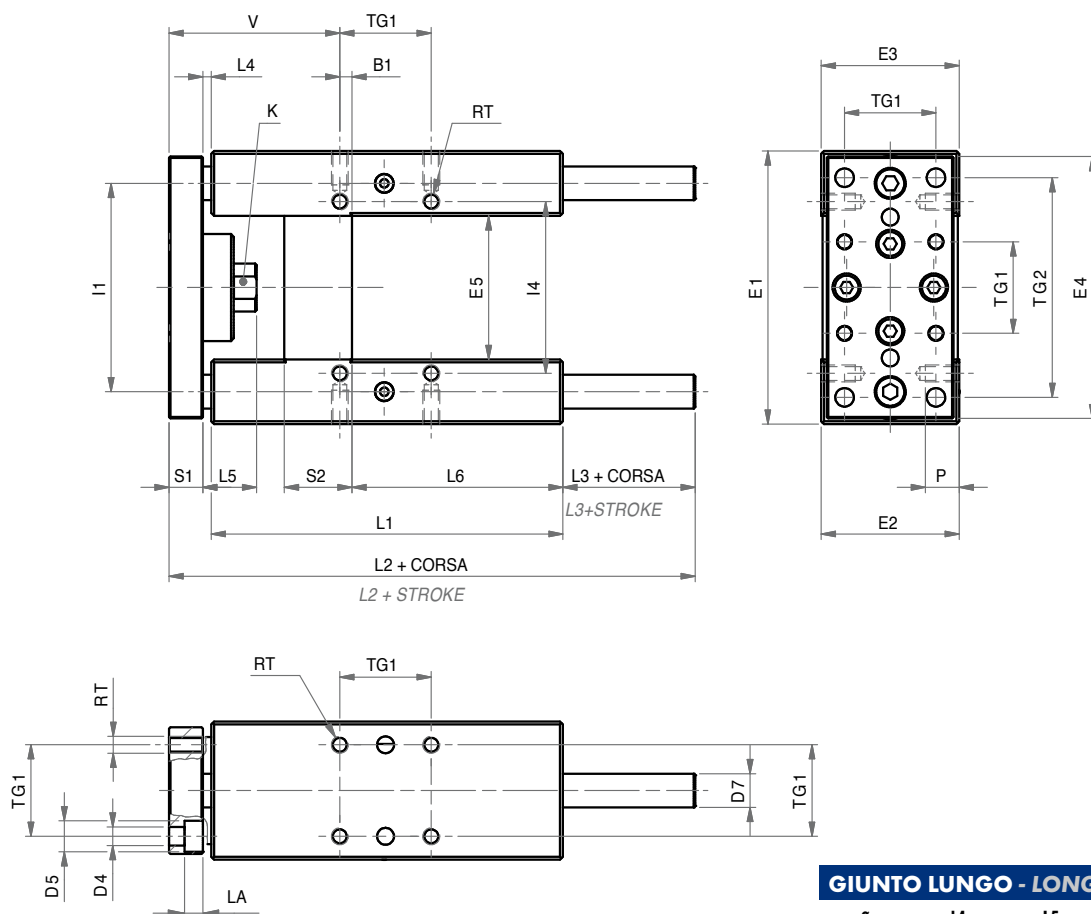

GIUNTO LUNGO - LONG COUPLING

Ø	L4	L5	L3	V
32	25	42	25	82,7
40	25	42	30	86
50	25	50	35	91,2
63	25	50	25	96,7
80	25	50	27	104
100	25	50	27	105

GIUNTO CORTO - SHORT COUPLING

Ø	B1	D4	D5	D7	E1	E2	E3	E4	E5	I1	I4	K	L1	L2	L3	L4	L5	L6	LA	P	RT	S1	S2	TG1	TG2	V
32	4,3	6,6	11	12	97	49	45	93	51	74	61	15	125	187	47	3	19,1	75	6,5	12	M6	12	24	32,5	78	60,7
40	11	6,6	11	16	115	58	55	112	58,2	87	69	15	140	207	52	3	24	80	6,5	12	M6	12	28	38	84	64
50	18,8	9	15	20	137	70	65	134	70,2	104	85	20	148	223	57	3	27	78	8,5	16	M8	15	34	46,5	100	69,2
63	15,3	9	15	20	152	85	80	147	85,2	119	100	20	178	243	47	3	27	106	9	16	M8	15	34	56,5	105	74,7
80	25	11	18	25	189	105	100	180	105,5	148	130	26	195	267	49	3	27	111	11	20	M10	20	50	72	130	82
100	30	11	18	25	213	130	120	206	130,5	173	150	26	218	290	49	3	27	128	11	20	M10	20	55	89	150	83

ACCESSORI DI FISSAGGIO ISO 6432 INOX

STAINLESS STEEL ISO 6432 MOUNTING PARTS

ACCESSORI DI FISSAGGIO INOX - STAINLESS STEEL MOUNTING PARTS

SERIE
Z

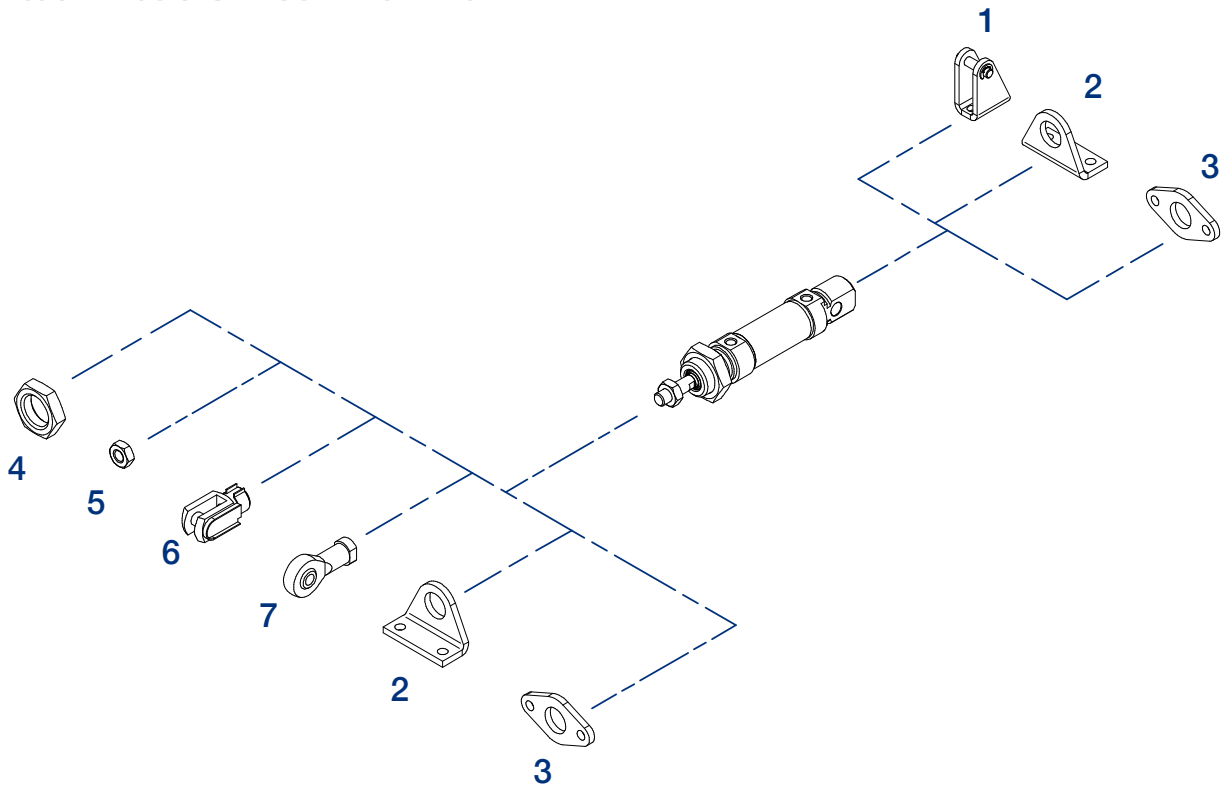

POS.	CODE	DESCRIZIONE-DESCRIPTION
1	MCFI---X	cerniera con perno - female hinge with pin
2	MPBI---X	pedino - foot mounting
3	MFI---X	flangia - flange
4	DAT---X	dado testata - nose nut
5	DA--x---X	dado stelo - rod nut
6	FP--x---X	forcella con perno - clevis with pin
7	SSFI--x---X	snodo sferico - rod eye

CERNIERA CON PERNO (MP3)

MCFIX

FEMALE HINGE WITH PIN (MP3)

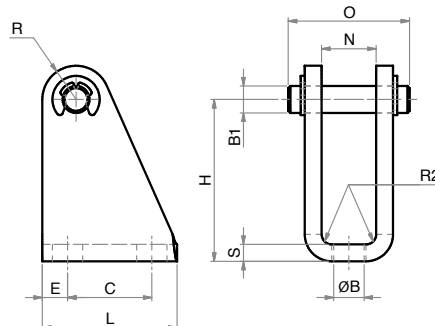

MATERIALE:
ACCIAIO INOX AISI 304
MATERIAL:
AISI 304 STAINLESS STEEL

DIMENSIONI - DIMENSIONS

COD.	MCFI008.010X	MCFI012.016X	MCFI020.025X
ø mm	8 - 10	12 - 16	20 - 25
B	4,5	5,5	6,6
B1	4	6	8
C	12,5	15	20
E	3,75	5	6
H	24	27	30
L	20	25	32
N	8,1	12,1	16,1
O	18	24	31
R	5	7	10
R2	1,5	1,5	2
S	2,5	3	4

PIEDINO INOX (MS3)

STAINLESS STEEL FOOT MOUNTING (MS3)

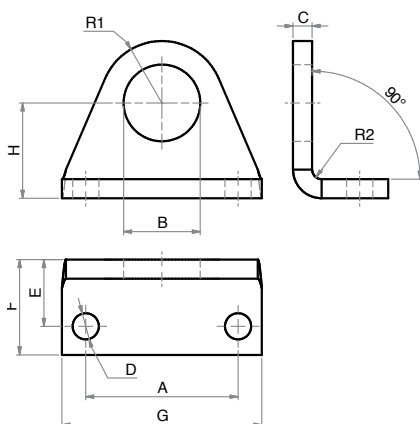

MATERIALE:
ACCIAIO INOX AISI 304
MATERIAL:
AISI 304 STAINLESS STEEL

DIMENSIONI - DIMENSIONS

COD.	MPBI008.010X	MPBI012.016X	MPBI020.025X
ø	8 - 10	12 - 16	20 - 25
A	25	32	40
B	12	16,1	22,1
C	3	4	5
D	4,5	5,5	6,6
E	11	14	17
F	16	20	25
G	35	42	54
H	16	20	25
R1	10	13	20
R2	1,5	2	2,5

FLANGIA INOX (MF8)

STAINLESS STEEL FLANGE (MF8)

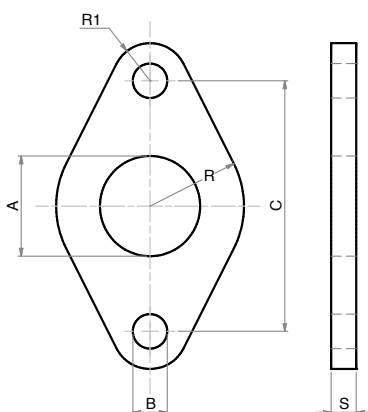

MATERIALE:
ACCIAIO INOX AISI 304
MATERIAL:
AISI 304 STAINLESS STEEL

DIMENSIONI - DIMENSIONS

COD.	MF1008.010X	MF1012.016X	MF1020.025X
ø	8 - 10	12 - 16	20 - 25
A	12	16	22
B	4,5	5,5	6,5
C	30	40	50
R	11	15	20
R1	5	6	8
S	3	4	5

DADO STELO

PISTON ROD NUT

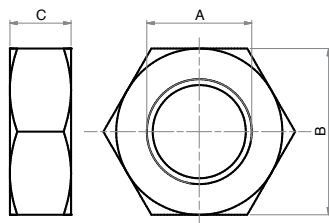

MATERIALE:
ACCIAIO INOX AISI 304
MATERIAL:
AISI 304 STAINLESS STEEL

DIMENSIONI - DIMENSIONS

COD.	DA06x1X	DA08x1,25X	DA10x1,25X
A	M6	M8	M10x1,25
B	10	13	17
C	4	5	6

DADO TESTATA (MR3)

NOSE NUT (MR3)

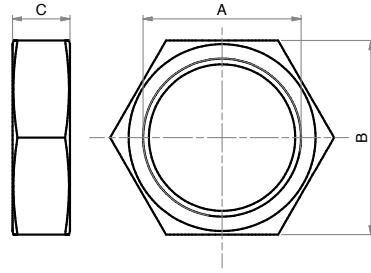

MATERIALE:
ACCIAIO INOX AISI 304
MATERIAL:
AISI 304 STAINLESS STEEL

DIMENSIONI - DIMENSIONS

COD.	DAT008.010X	DAT012.016X	DAT020.025X
A	M12x1,25	M16x1,5	M22x1,5
B	19	22	27
C	7	5	8

FORCELLA CON PERNO INOX

STAINLESS STEEL CLEVIS WITH PIN

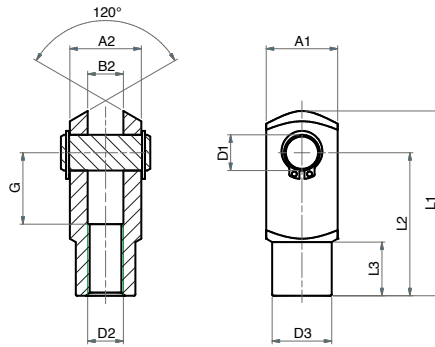

MATERIALE:
ACCIAIO INOX AISI 304
MATERIAL:
AISI 304 STAINLESS STEEL

LA FORNITURA COMPRENDE:
n° 1 PERNO
n° 2 SEEGER
THE SUPPLY INCLUDES:
n° 1 PIN
n° 2 RETAINING RING

DIMENSIONI - DIMENSIONS

COD.	FP06x1X	FP08x1,25X	FP10x1,25X
A1	12	16	20
A2	12	16	20
B2	6	8	10
G	12	16	20
L1	31	42	52
L2	24	32	40
L3	9	12	15
ø D2	M6x1	M8x1,25	M10x1,25
ø D3	10	14	18
ø D1	6	8	10

SNODO SFERICO INOX

STAINLESS STEEL ROD EYE

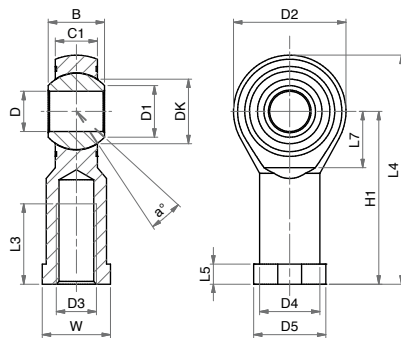

MATERIALE:
CORPO IN ACCIAIO INOX AISI 304
SNODO IN ACCIAIO INOX E PTFE
MATERIAL:
BODY IN AISI 304 STAINLESS STEEL
EYE IN STAINLESS STEEL AND PTFE

DIMENSIONI - DIMENSIONS

COD.	SSF106x1X	SSF108x1,25X	SSF110x1,25X
α°	13	14	13
B	9	12	14
C1	6,75	9	10,5
D1	8,9	10,4	12,9
D2	20	24	28
D3	M6	M8	M10x1,25
D4	10	12,5	15
D5	13	16	19
DK	12,7	15,87	19,05
D	6	8	10
H1	30	36	43
L3	12	16	20
L4	40	48	57
L5	5	5	6,5
L7	11	13	15
W	11	14	17

ACCESSORI DI FISSAGGIO CILINDRO TONDO INOX

STAINLESS STEEL ROUND CYLINDER MOUNTING PARTS

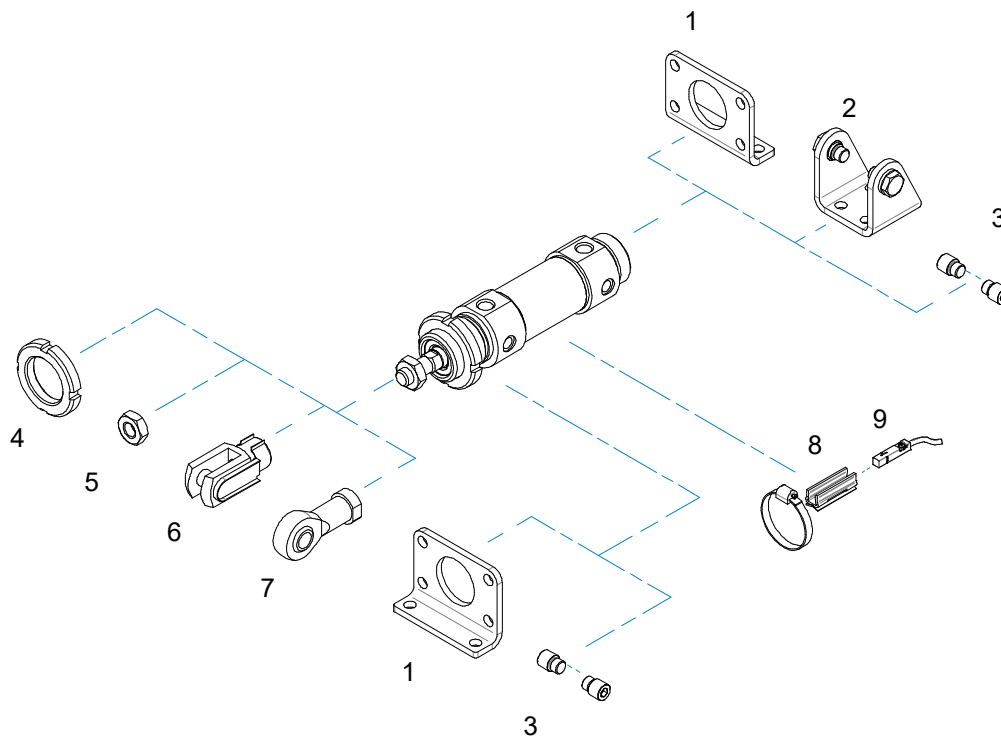

POS.	CODE	DESCRIZIONE - DESCRIPTION
1	MCFI---X	cerniera con viti - hinge with screws
2	MPBI---X	pedino flangia - foot flange
3	MPE---X	perni - pivots
4	GHI---X	ghiera - slotted nut
5	DA--x---X	dado stelo - rod nut
6	FP--x---X	forcella con perno - clevis with pin
7	SSFI--x---X	snodo sferico - rod eye

PIEDINO FLANGIA

MPBI X

FOOT FLANGE



MATERIALE:
ACCIAIO INOX AISI 304
MATERIAL:
AISI 304 STAINLESS STEEL

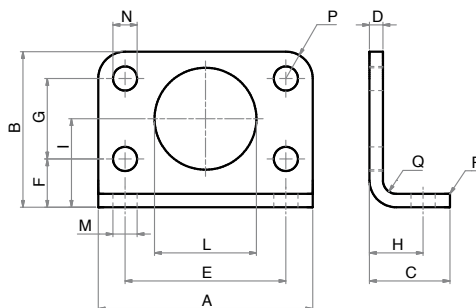

DIMENSIONI - DIMENSIONS				
COD.	MPBI032X	MPBI040X	MPBI050X	MPBI063X
ø mm	32	40	50	63
A	66	80	90	96
B	49	58	70	80
C	21	30	30	30
D	4	5	6	6
E	52	60	70	76
F	14	18	20	20
G	28	30	40	50
H	14	20	20	20
I	28	33	40	45
L	30	38	45	45
M	7	9	9	9
N	7	9	9	9
P	7	10	10	10
Q	4	5	6	6
R	2	2	2	2

CERNIERA CON VITI

HINGE WITH SCREWS

ACCESSORI DI FISSAGGIO INOX - STAINLESS STEEL MOUNTING PARTS

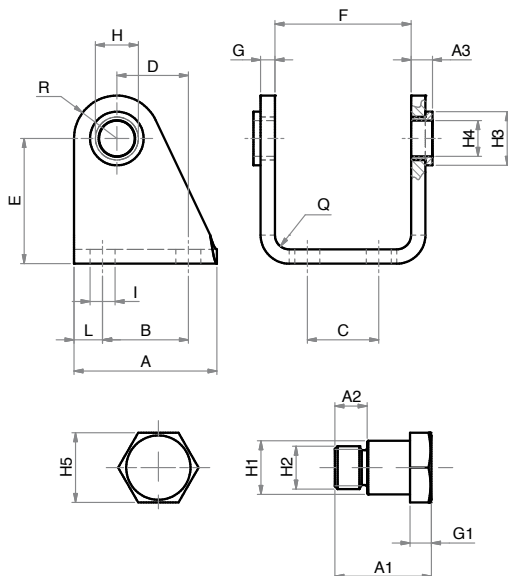

MATERIALE:
ACCIAIO INOX AISI 304
MATERIAL:
AISI 304 STAINLESS STEEL

DIMENSIONI - DIMENSIONS

COD.	MCFI032X	MCFI040X	MCFI050X	MCFI063X
Ø mm	32	40	50	63
A	40	50	54	65
A1	18	21,6	26,4	31,5
A2	6	7	9	13
A3	6	7	8,5	8,5
B	24	30	34	35
C	20	28	36	42
D	20	27	30	34
E	35	40	45	50
F	38,1	46,1	57,1	70,1
G	4	5	6	6
G1	4	5	6	6
H	12	15	18	20
H1	10	12	14	16
H2	M8x1	M10x1	M12x1,5	M14x1,5
H3	15	20	23	23
H4	10	12	14	16
H5	13	17	19	19
I	7	9	9	9
L	8	10	10	15
P	12	13	14	16
Q	4	5	6	6

PERNI (COPPIA)

PIVOTS (2pcs)

SERIE

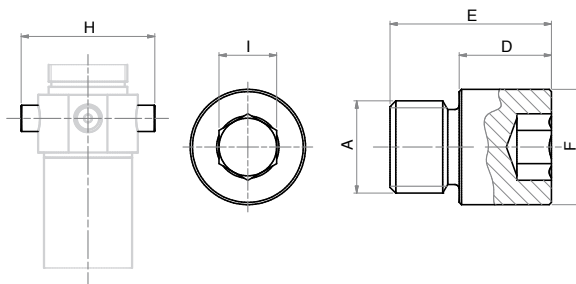

MATERIALE:
ACCIAIO INOX AISI 304
MATERIAL:
AISI 304 STAINLESS STEEL

DIMENSIONI - DIMENSIONS

COD.	MPE032X	MPE040X	MPE050X	MPE063X
Ø mm	32	40	50	63
A	M8x1	M10x1	M12x1,5	M14x1,5
D	8	9,5	11	13
E	14	16,5	20	28
F	10	12	14	16
I	5	6	6	8
H	51	61	75	92

GHIERA

SLOTTED NUT

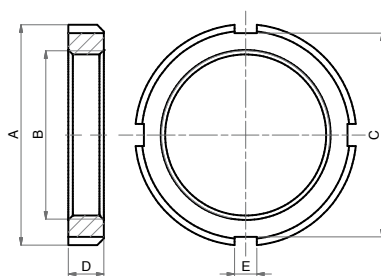

MATERIALE:
ACCIAIO INOX AISI 304
MATERIAL:
AISI 304 STAINLESS STEEL

DIMENSIONI - DIMENSIONS

COD.	GHI032X	GHI040X	GHI050.63X
Ø mm	32	40	50 - 63
A	45	50	58
B	M30x1,5	M38x1,5	M45x1,5
C	40	46	52
D	7	8	9
E	5	5	6

SERIE



DADO STELO INOX

STAINLESS STEEL ROD NUT

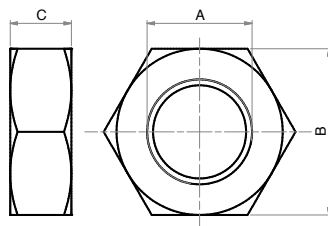

MATERIALE:
ACCIAIO INOX AISI 304
MATERIAL:
AISI 304 STAINLESS STEEL

DIMENSIONI - DIMENSIONS

COD.	DA10x1,25X	DA12x1,25X	DA16x1,5X
A	M10x1,25	M12x1,25	M16x1,5
B	17	19	24
C	6	7	8

FORCELLA CON PERNO INOX

STAINLESS STEEL CLEVIS WITH PIN

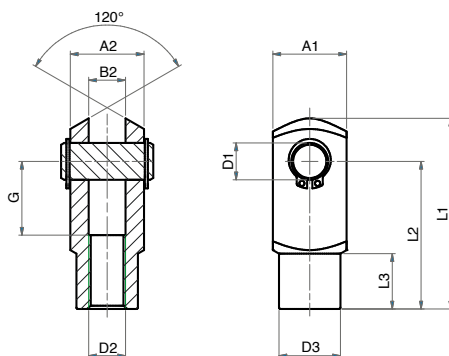

MATERIALE:
ACCIAIO INOX AISI 304
MATERIAL:
AISI 304 STAINLESS STEEL

LA FORNITURA COMPRENDE:
n° 1 PERNO
n° 2 SEEGER
THE SUPPLY INCLUDES:
n° 1 PIN
n° 2 RETAINING RING

DIMENSIONI - DIMENSIONS

COD.	FP10x1,25X	FP12x1,25X	FP16x1,5X
A1	20	24	32
A2	20	24	32
B2	10	12	16
G	20	24	32
L1	52	62	83
L2	40	48	64
L3	15	18	24
ø D2	M10x1,25	M12x1,25	M16x1,5
ø D3	18	20	26
ø D1	10	12	16

SNODO SFERICO INOX

STAINLESS STEEL ROD EYE

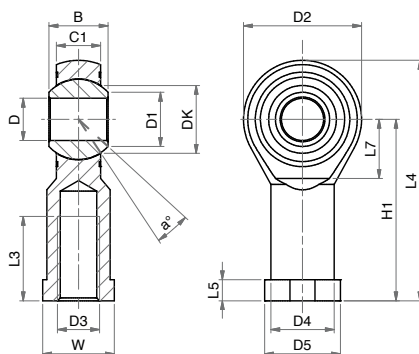

MATERIALE:
CORPO IN ACCIAIO INOX AISI 304
SNODO IN ACCIAIO INOX E PTFE
MATERIAL:
BODY IN AISI 304 STAINLESS STEEL
EYE IN STAINLESS STEEL AND PTFE

DIMENSIONI - DIMENSIONS

COD.	SSF10x1,25X	SSF12x1,25X	SSF16x1,5X
α°	13	13	15
B	14	16	21
C1	10,5	12	15
D1	12,9	15,4	19,3
D2	28	32	42
D3	M10x1,25	M12x1,25	M16x1,5
D4	15	17,5	22
D5	19	22	27
DK	19,05	22,22	28,57
D	10	12	16
H1	43	50	64
L3	20	22	28
L4	57	66	85
L5	6,5	6,5	8
L7	15	17	23
W	17	19	22



ACCESSORI DI FISSAGGIO ISO 15552 INOX (UTILIZZABILI ANCHE PER CILINDRI ISO 21287)

STAINLESS STEEL ISO 15552 MOUNTING PARTS (ALSO SUITABLE FOR ISO 21287 CYLINDERS)

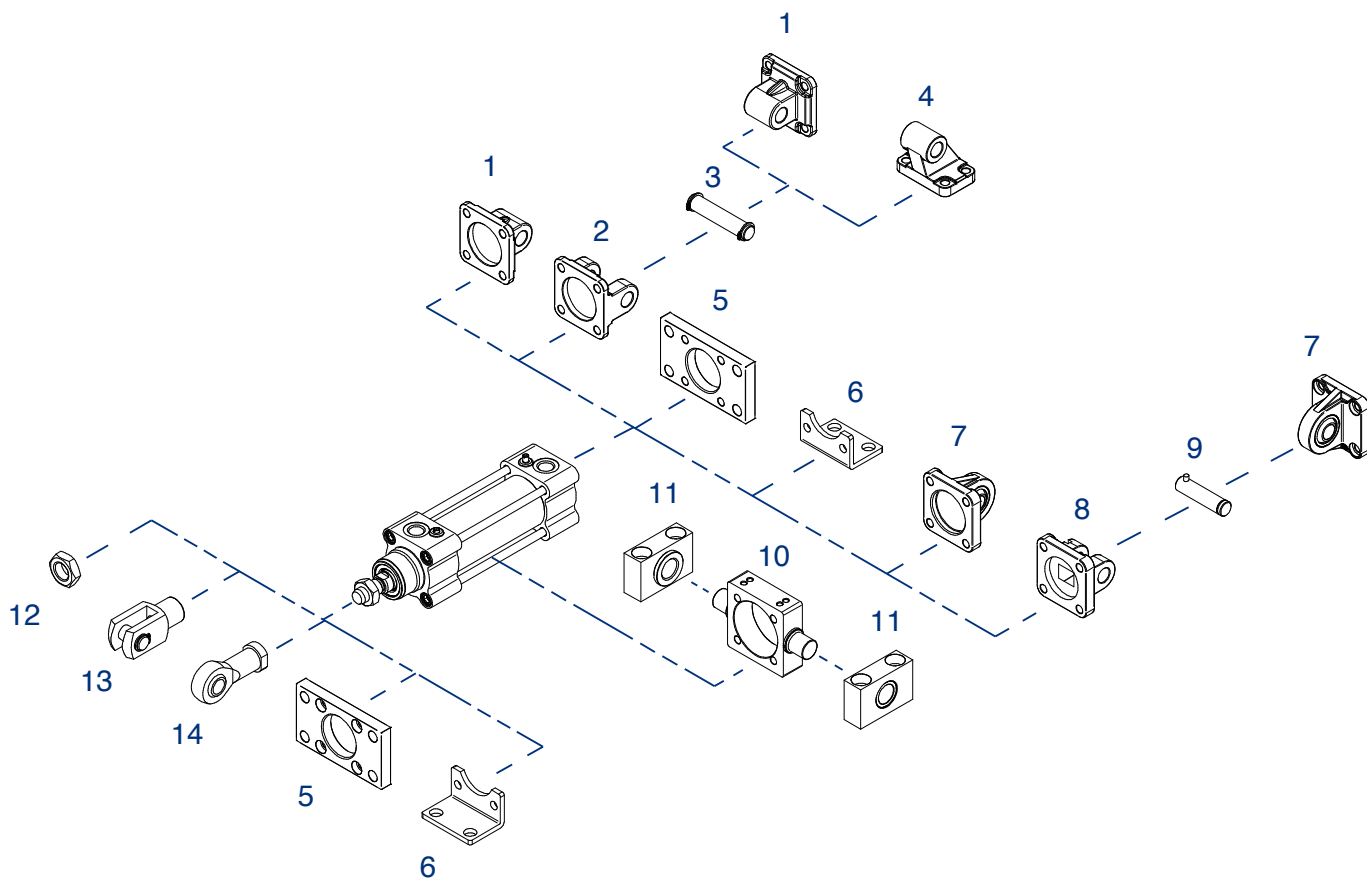

ACCESSORI DI FISSAGGIO INOX - STAINLESS STEEL MOUNTING PARTS

SERIE
Y

SERIE
X

POS.	CODE	DESCRIZIONE - DESCRIPTION
1	CMI---X	cerniera maschio iso - <i>iso male hinge</i>
2	CFI---X	cerniera femmina iso - <i>iso female hinge</i>
3	PCF---X	perno per cerniera - <i>pin for hinge</i>
4	ASI---X	articolazione a squadra iso - <i>iso square hinge</i>
5	FI---X	flangia iso - <i>iso flange</i>
6	PBI---X	pedino basso iso - <i>iso foot mounting</i>
7	CMSI---X	cerniera maschio snodata iso - <i>iso male hinge with ball joint</i>
8	CFSI---X	cerniera femmina stretta iso - <i>iso narrow female hinge</i>
9	PCFS---X	perno per cerniera stretta - <i>pin for narrow hinge</i>
10	CICT---X	cerniera intermedia per tiranti - <i>intermediate hinge for tie rod</i>
11	SCI---X	supporto cerniera intermedia - <i>support for intermediate hinge</i>
12	DA--x---X	dado - <i>nut</i>
13	FP--x---X	forcella con perno - <i>clevis with pin</i>
14	SSFI--x---X	snodo sferico - <i>rod eye</i>

Fissaggi forniti con viti - *Mounting parts supplied with screws*

CERNIERA MASCHIO ISO INOX (MP4)

STAINLESS STEEL ISO MALE HINGE (MP4)

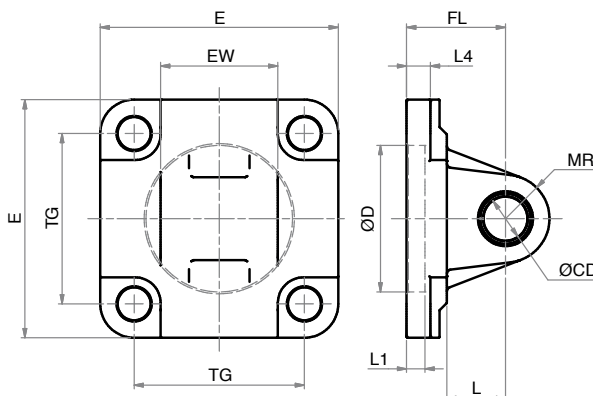

LA FORNITURA COMPRENDE:
n° 1 CERNIERA MASCHIO
n° 4 VITI
THE SUPPLY INCLUDES:
n° 1 MALE HINGE
n° 4 SCREWS

MATERIALE:
ACCIAIO INOX AISI 304
MATERIAL:
AISI 304 STAINLESS STEEL

DIMENSIONI - DIMENSIONS

COD.	CMI032X	CMI040X	CMI050X	CMI063X	CMI080X	CMI100X	CMI125X
Ø	32	40	50	63	80	100	125
E	45	52	65	75	93	110	134
EW	26	28	32	40	50	60	70
TG	32,5	38	46,5	56,5	72	89	110
FL	22	25	27	32	36	41	50
L1	5	5	5	5	5	5	7
L	13	16	16	21	22	27	30
L4	5,5	5,5	6,5	6,5	10	10	10
Ø D	30	35	40	45	45	55	60
Ø CD	10	12	12	16	16	20	25
MR	10	12	12	16	16	20	25

CERNIERA FEMMINA ISO INOX (MP2)

STAINLESS STEEL ISO FEMALE HINGE (MP2)

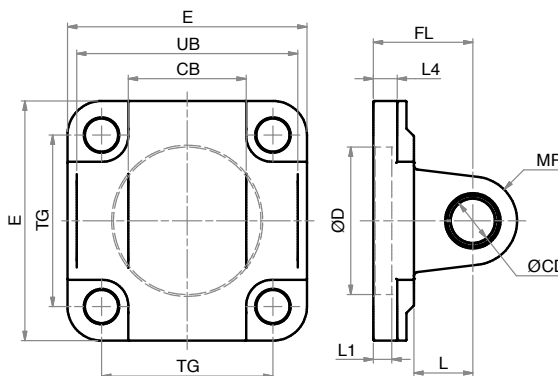

LA FORNITURA COMPRENDE:
n° 1 CERNIERA FEMMINA
n° 4 VITI
THE SUPPLY INCLUDES:
n° 1 FEMALE HINGE
n° 4 SCREWS

MATERIALE:
ACCIAIO INOX AISI 304
MATERIAL:
AISI 304 STAINLESS STEEL

DIMENSIONI - DIMENSIONS

COD.	CFI032X	CFI040X	CFI050X	CFI063X	CFI080X	CFI100X	CFI125X
Ø	32	40	50	63	80	100	125
CB	26	28	32	40	50	60	70
E	45	52	65	75	93	110	134
FL	22	25	27	32	36	41	50
L1	5	5	5	5	5	5	7
L4	5,5	5,5	6,5	6,5	10	10	10
L	13	16	16	21	22	27	30
MR	10	12	12	16	16	20	25
Ø CD	10	12	12	16	16	20	25
Ø D	30	35	40	45	45	55	60
TG	32,5	38	46,5	56,5	72	89	110
UB	45	52	60	70	90	110	130

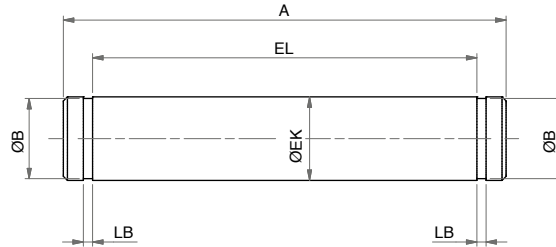
PERNO PER CERNIERA INOX (AA4)
PCF X
STAINLESS STEEL PIN FOR HINGE (AA4)

LA FORNITURA COMPRENDE:
n° 1 PERNO
n° 2 SEEGER
THE SUPPLY INCLUDES:
n° 1 PIN
n° 2 RETAINING RING

MATERIALE:
ACCIAIO INOX AISI 304
MATERIAL:
AISI 304 STAINLESS STEEL

DIMENSIONI - DIMENSIONS

COD.	PCF032X	PCF040X	PCF050X	PCF063X	PCF080X	PCF100X	PCF125X
Ø	32	40	50	63	80	100	125
A	53	60	68	78	98	118	139
Ø B	9,6	11,5	11,5	15,2	15,2	19	23,9
EL	46	53	61	71	91	111	132
Ø EK	10	12	12	16	16	20	25
LB	1,1	1,1	1,1	1,1	1,1	1,3	1,3

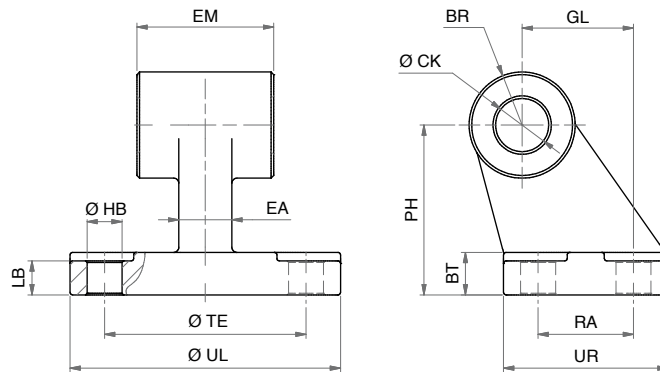
ARTICOLAZIONE A SQUADRA ISO INOX (AB7)
ASI X
STAINLESS STEEL ISO SQUARE HINGE (AB7)

LA FORNITURA COMPRENDE:
n° 1 ARTICOLAZIONE A SQUADRA
THE SUPPLY INCLUDES:
n° 1 SQUARE HINGE

MATERIALE:
ACCIAIO INOX AISI 304
MATERIAL:
AISI 304 STAINLESS STEEL

DIMENSIONI - DIMENSIONS

COD.	ASI032X	ASI040X	ASI050X	ASI063X	ASI080X	ASI100X	ASI125X
Ø	32	40	50	63	80	100	125
BR	10	11	13	15	15	19	22,5
BT	8	10	12	14	14	17	20
CK	10	12	12	16	16	20	25
EA	10	15	16	16	20	20	30
EM	26	28	32	40	50	60	70
GL	21	24	33	37	47	55	70
LB	6,4	8,4	10,4	12,4	11,5	14,5	16,8
Ø HB	6,6	6,6	9	9	11	11	14
PH	32	36	45	50	63	71	90
RA	18	22	30	35	40	50	60
TE	38	41	50	52	66	76	94
UL	51	54	65	67	86	96	124
UR	31	35	45	50	60	70	90

FLANGIA ISO INOX (MF1 - MF2)

STAINLESS STEEL ISO FLANGE (MF1 - MF2)

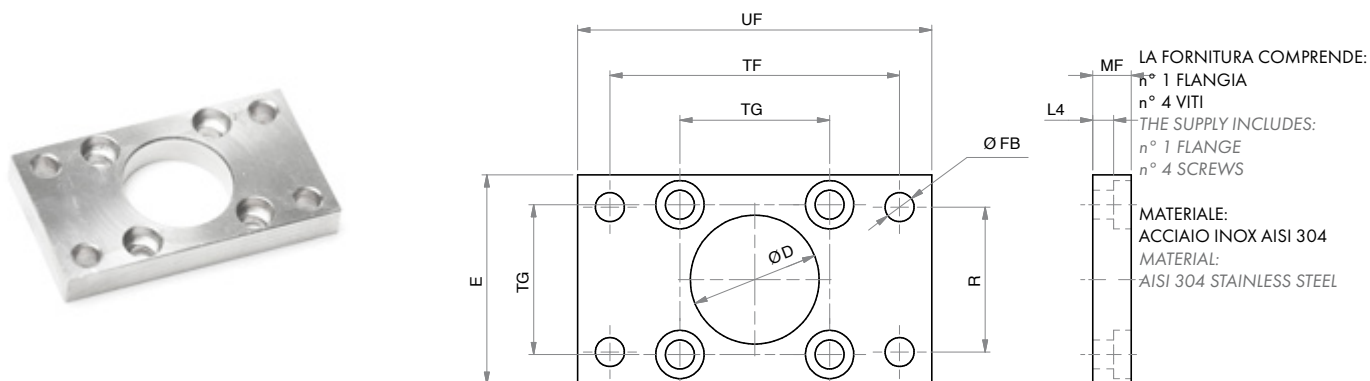

DIMENSIONI - DIMENSIONS

COD.	FI032X	FI040X	FI050X	FI063X	FI080X	FI100X	FI125X
Ø	32	40	50	63	80	100	125
E	45	52	65	75	95	115	140
L4	5	5	6,5	6,5	9	9	10,5
MF	10	10	12	12	16	16	20
Ø D	30	35	40	45	45	55	60
Ø FB	7	9	9	9	12	14	16
R	32	36	45	50	63	75	90
TF	64	72	90	100	126	150	180
TG	32,5	38	46,5	56,5	72	89	110
UF	80	90	110	120	150	170	205

PIEDINO BASSO ISO INOX (MS1)

STAINLESS STEEL ISO FOOT MOUNTING (MS1)

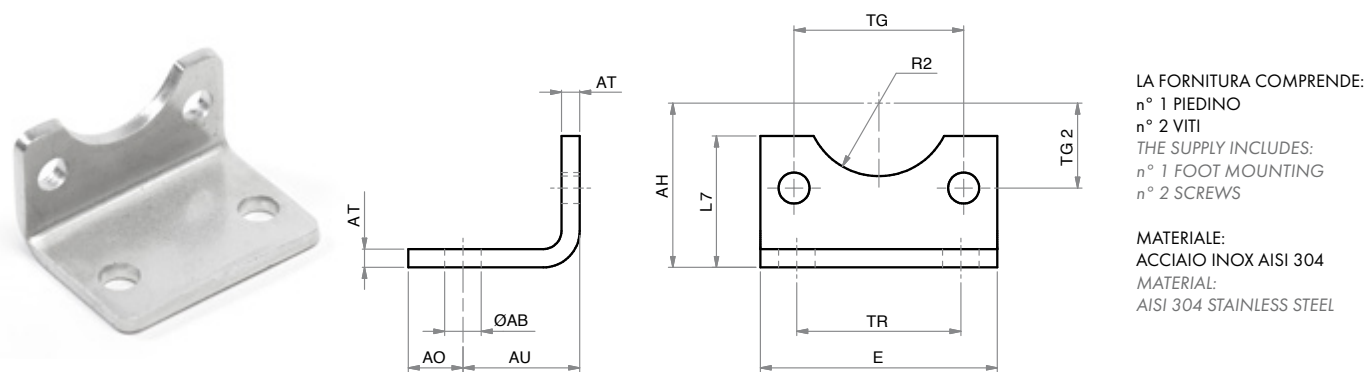

DIMENSIONI - DIMENSIONS

COD.	PBI032X	PBI040X	PBI050X	PBI063X	PBI080X	PBI100X	PBI125X
Ø	32	40	50	63	80	100	125
AH	32	36	45	50	63	71	90
AO	11	8	15	13	14	16	25
AT	4	4	5	5	6	6	8
AU	24	28	32	32	41	41	45
E	45	52	65	75	95	115	140
L7	30	30	36	35	47	53	70
Ø AB	7	10	10	10	12	14,5	16,5
R2	15	17,5	20	22,5	22,5	27,5	30
TG2	16,25	19	23,25	28,25	36	44,5	55
TG	32,5	38	46,5	56,5	72	89	110
TR	32	36	45	50	63	75	90

CERNIERA MASCHIO SNODATA ISO INOX (MP6)

STAINLESS STEEL ISO MALE HINGE WITH BALL JOINT (MP6)

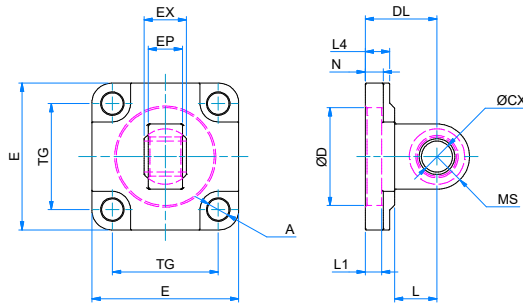

LA FORNITURA COMPRENDE:
n° 1 CERNIERA MASCHIO
n° 4 VITI
THE SUPPLY INCLUDES:
n° 1 MALE HINGE
n° 4 SCREWS

MATERIALE:
ACCIAIO INOX AISI 316
MATERIAL:
AISI 316 STAINLESS STEEL

DIMENSIONI - DIMENSIONS

COD.	CMSI032X6	CMSI040X6	CMSI050X6	CMSI063X6	CMSI080X6	CMSI100X6	CMSI125X6
ø	32	40	50	63	80	100	125
A	6,6	6,6	9	9	11	11	13,5
DL	22	25	27	32	36	41	50
EP	10,5	12	15	15	18	18	25
EX	14	16	21	21	25	25	37
E	45	55	65	75	95	115	140
L1	5	5	5	5	5	5	7
L4	8	8	10	10	13	13	16
L	12	15	15	20	20	25	30
MS	15	18	20	23	27	30	40
N	5,5	5,5	6,5	6,5	10	10	10
ø CX	10	12	16	16	20	20	30
ø D	30	35	40	45	45	55	60
TG	32,5	38	46,5	56,5	72	89	110

CERNIERA FEMMINA STRETTA ISO INOX (AB6)

STAINLESS STEEL ISO NARROW FEMALE HINGE (AB6)

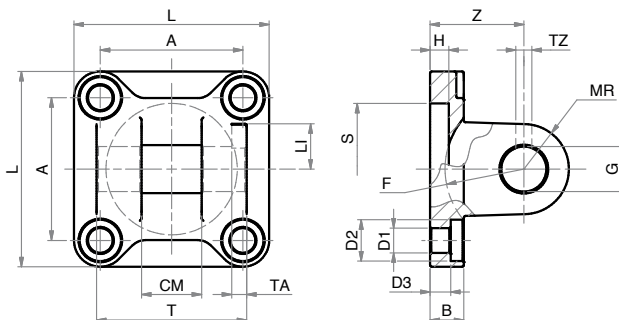

LA FORNITURA COMPRENDE:
n° 1 CERNIERA FEMMINA
n° 4 VITI
THE SUPPLY INCLUDES:
n° 1 FEMALE HINGE
n° 4 SCREWS

MATERIALE:
ACCIAIO INOX AISI 316
MATERIAL:
AISI 316 STAINLESS STEEL

DIMENSIONI - DIMENSIONS

COD.	CFSI032X6	CFSI040X6	CFSI050X6	CFSI063X6	CFSI080X6	CFSI100X6	CFSI125X6
ø	32	40	50	63	80	100	125
A	32,5	38	46,5	56,5	72	89	110
B	9	9	11	11	14	14	20
CM	14	16	21	21	25	25	37
D1	6,6	6,6	9	9	11	11	14
D2	11	11	15	15	18	18	20
D3	5,5	5,5	6,5	6,5	10	10	10
F min.	17	20	22	25	30	32	42
G	10	12	16	16	20	20	30
H	5	5	5	5	5	5	7
LI	11,5	12	14	14	16	16	24
L	45	52	65	75	95	115	140
MR	10	12	14	18	20	22	25
S	30	35	40	45	45	55	60
TA	3	4	4	4	4	4	6
TZ	3,3	4,3	4,3	4,3	4,3	6,3	6,3
T	34	40	45	51	65	75	97
Z	22	25	27	32	36	41	50

PERNO PER CERNIERA STRETTA INOX (AA6)

STAINLESS STEEL PIN FOR NARROW HINGE (AA6)

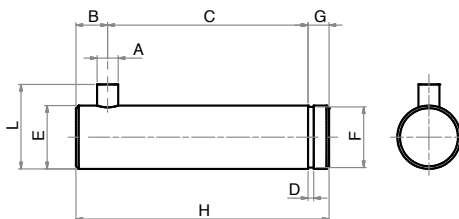

LA FORNITURA COMPRENDE:
n° 1 PERNO
n° 1 SEEGER
THE SUPPLY INCLUDES:
n° 1 PIN
n° 1 RETAINING RING

MATERIALE:
ACCIAIO INOX AISI 316
MATERIAL:
AISI 316 STAINLESS STEEL

DIMENSIONI - DIMENSIONS

COD.	PCFS032X6	PCFS040X6	PCFS050X6	PCFS063X6	PCFS080X6	PCFS100X6	PCFS125X6
ø	32	40	50	63	80	100	125
A	3	4	4	4	4	4	6
B	4,5	6	6	6	6	6	9
C	32,5	38	43	49	63	73	94
D	1,1	1,1	1,1	1,1	1,3	1,3	1,6
E	10	12	16	16	20	20	30
F	9,6	11,5	15,2	15,2	19	19	28,6
G	4	4	5	5	6	6	7
H	41	48	54	60	75	85	110
L	14	16	20	20	24	24	36

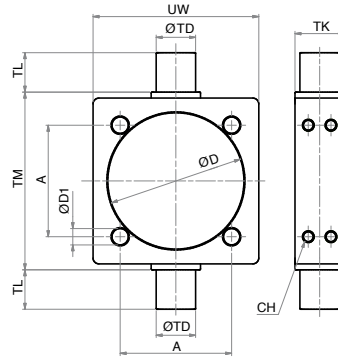
CERNIERA INTERMEDIA INOX SERIE Y (MT4)
STAINLESS STEEL INTERMEDIATE HINGE SERIE Y (MT4)

MATERIALE:
ACCIAIO INOX AISI 304
MATERIAL:
AISI 304 STAINLESS STEEL

LA FORNITURA COMPRENDE:
N° 1 CERNIERA INTERMEDIA
THE SUPPLY INCLUDES:
N° 1 INTERMEDIATE HINGE

DIMENSIONI - DIMENSIONS

COD.	CICT032X	CICT040X	CICT050X	CICT063X	CICT080X	CICT100X	CICT125X
ø	32	40	50	63	80	100	125
A	32,5	38	46,5	56,5	72	89	110
CH	2,5	2,5	3	3	4	4	5
ø D1	6,25	6,25	8,25	8,25	10,25	10,25	12,25
ø D	37	46	56	69	87	107	133
ø TD	12	16	16	20	20	25	25
TK	15	20	20	25	25	30	32
TL	12	16	16	20	20	25	25
TM	50	63	75	90	110	132	160
UW	46	59	69	84	102	125	155

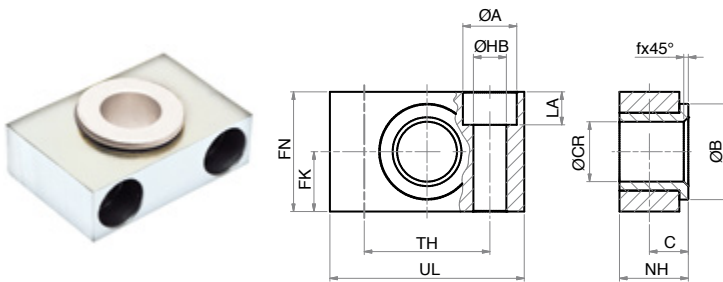
SUPPORTO PER CERNIERA INTERMEDIA (AT4)
SUPPORT FOR INTERMEDIATE HINGE (AT4)

LA FORNITURA COMPRENDE: N° 1 SUPPORTO, N° 2 VITI
THE SUPPLY INCLUDES: n° 1 SUPPORT, n° 2 SCREWS
MATERIALE: CORPO IN ACCIAIO INOX 316, BOCCOLA IN TECNOPOLIMERO
MATERIAL: BODY IN AISI 316 STAINLESS STEEL, BUSH IN TECHNOPLYMER

DIMENSIONI - DIMENSIONS

COD.	SCI032X6	SCI040.050X6	SCI063.080X6	SCI100.125X6
ø	32	40-50	63-80	100-125
C	10,5	12	13	16
FK	15	18	20	25
FN	30	36	40	50
f	1	1,6	1,6	2
LA	7	9	11	13
NH	18	21	23	28,5
ø A	11	15	18	20
ø B	22	28	32	39
ø CR	12	16	20	25
ø HB	6,6	9	11	14
TH	32	36	42	50
UL	46	55	65	75

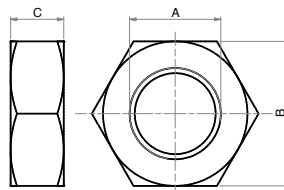
DADO STELO
PISTON ROD NUT

MATERIALE:
ACCIAIO INOX AISI 304
MATERIAL:
AISI 304 STAINLESS STEEL

DIMENSIONI - DIMENSIONS

COD.	DA06x1X	DA08x1,25X	DA10x1,25X	DA12x1,25X	DA16x1,5X	DA20x1,5X	DA27x2X	DA36x2X	DA42x2X	DA48x2X
A	M6	M8	M10x1,25	M12x1,25	M16x1,5	M20x1,5	M27x2	M36x2	M42x2	M48x2
B	10	13	17	19	24	30	41	55	65	75
C	4	5	6	7	8	9	12	14	16	18

SNODO SFERICO INOX (FILETTO INTERNO)

STAINLESS STEEL ROD EYE (INTERNAL THREAD)

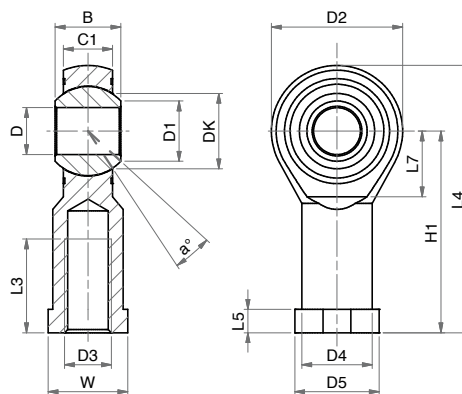

MATERIALE:
CORPO IN ACCIAIO
INOX AISI 304
SNODO IN ACCIAIO
INOX E PTFE
MATERIAL:
BODY IN
AISI 304 STAINLESS STEEL
EYE IN STAINLESS STEEL
AND PTFE

DIMENSIONI - DIMENSIONS

COD.	SSFI08x1,25X	SSFI10x1,25X	SSFI12x1,25X	SSFI16x1,5X	SSFI20x1,5X	SSFI27x2X	SSFI36x2X
α°	14	13	13	15	14	17	16
B	12	14	16	21	25	37	43
C1	9	10,5	12	15	18	25	28
D1	10,4	12,9	15,4	19,3	24,3	34,8	37,7
D2	24	28	32	42	50	70	80
D3	M8	M10x1,25	M12x1,25	M16x1,5	M20x1,5	M27x2	M36x2
D4	12,5	15	17,5	22	27,5	40	46
D5	16	19	22	27	34	50	58
DK	15,87	19,05	22,22	28,57	34,92	50,8	57,15
D	8	10	12	16	20	30	35
H1	36	43	50	64	77	110	125
L3	16	20	22	28	33	51	56
L4	48	57	66	85	102	145	165
L5	5	6,5	6,5	8	10	15	17
L7	13	15	17	23	27	36	41
W	14	17	19	22	30	41	50

FORCELLA CON PERNO INOX

STAINLESS STEEL CLEVIS WITH PIN

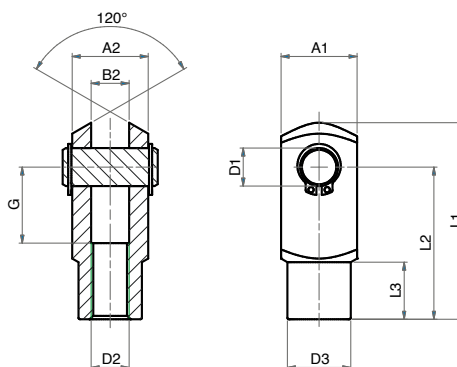

MATERIALE:
ACCIAIO INOX AISI 304
MATERIAL:
AISI 304 STAINLESS STEEL

LA FORNITURA COMPRENDE:
n° 1 PERNO
n° 2 SEEGER
THE SUPPLY INCLUDES:
n° 1 PIN
n° 2 RETAINING RING

DIMENSIONI - DIMENSIONS

COD.	FP08x1,25X	FP10x1,25X	FP12x1,25X	FP16x1,5X	FP20x1,5X	FP27x2X	FP36x2X
A1	16	20	24	32	40	55	70
A2	16	20	24	32	40	55	70
B2	8	10	12	16	20	30	35
G	16	20	24	32	40	54	72
L1	42	52	62	83	105	148	188
L2	32	40	48	64	80	110	144
L3	12	15	18	24	30	38	40
ø D2	M8x1,25	M10x1,25	M12x1,25	M16x1,5	M20x1,5	M27x2	M36x2
ø D3	14	18	20	26	34	48	60
ø D1	8	10	12	16	20	30	35

SENSORI MAGNETICI

MAGNETIC SENSORS

CARATTERISTICHE - CHARACTERISTICS

CODICE - CODE	36.SEN06 36.SEN06.L6	36.SEN07	36.SEN08	36.SEN09 36.SEN09.L6 36.SEN09.L10
TIPO - TYPE	REED	REED	ELETTRONICO ELECTRONIC	ELETTRONICO ELECTRONIC
Modello elettrico - Electrical design	AC/DC PNP/NPN	AC/DC PNP/NPN	DC PNP	DC PNP
Funzione dell'uscita - Output	NO	NO	NO	NO
Tensione di esercizio - Operating voltage	[V] 5...120 AC/DC	5...60 DC / 5...50 AC	10...30 DC	10...30 DC
Capacità di corrente - Current rating	[mA] 100*	100*	100	100
Sensibilità di reazione - Magnetic sensitivity	[mT] 2,1	2,1	2,8	2,8
Velocità di passaggio - Travel speed	[m/s] > 10	> 10	> 10	> 10
Protezione da cortocircuito - Short-circuit proof	no	no	si - yes	si - yes
Protetto da inversione di polarità Reverse polarity protection	si - yes	si - yes	si - yes	si - yes
Resistente a sovraccarico - Overload protection	no	no	si - yes	si - yes
Caduta di tensione - Voltage drop	[V] < 5	< 5	< 2,5	< 2,5
Isteresi - Hysteresis	1	1	< 1,5	< 1,5
Riproducibilità - Repeatability	[mm] ± 0,2	± 0,2	< 0,2	< 0,2
Corrente assorbita - Current consumption	[mA] -	-	< 10	< 10
Tempo di commutazione - Make time	[ms] ≤ 0,6	≤ 0,6	-	-
Tempo di riapertura - Fall time	[ms] ≤ 0,1	≤ 0,1	-	-
Potenza max - Switching power max	[W] 10	10	-	-
Cicli di commutazione con connessione a PLC Switching cycles when connected to PLC	[mln] ≤ 40	≤ 40	-	-
Frequenza di commutazione - Switching frequency	[Hz] 1.000	1.000	> 10.000	> 10.000
Temperatura ambiente - Ambient temperature	[°C] -25...70	-25...70	-25...80	-25...80
Grado/Classe di protezione - Protection	IP67, II	IP67, II	IP67, III	IP67, III
Materiale involucro - Housing material	PA (poliammide - polyamide)			
Materiale eccentrico di fissaggio - Fastening clamp	inox - stainless steel			
Indicazione della funzione Stato di commutazione Function display Switching status	LED	giallo - yellow		
Collegamento - Connection	cavo PUR - PUR cable 2x0,14 mm ² 2 m (.L6 = 6 m)	cavo PUR - PUR cable connettore M8- M8 connector 0,3 m	cavo PUR - PUR cable connettore M8- M8 connector 0,3 m	cavo PUR - PUR cable 3x0,14 mm ² 2 m (.L6 = 6 m .L10 = 10 m)
Peso - Weight	[g] 31,3 69	12	12,1	27,4 73,5 122,4

Accessori inclusi: Segnaposto in gomma, fascetta fermacavo - Accessories included: Rubber placeholder, cable clip

*: necessario circuito di protezione esterno per carico induttivo (valvola, relè, ecc...). - External protective circuit for inductive load (valve, contactor, etc...) necessary.

SERIE M nessuna funzione LED in caso di inversione di polarità nel funzionamento DC. - No LED function in case of polarity reversal in DC operation.

M i sensori possono essere utilizzati solo sulle pinze M16 e M32

These sensors can be used only in grippers M16 and M32

CONTATTO REED (2 FILI)

36.SEN06

36.SEN06.L6

REED CONTACT (2 WIRES)

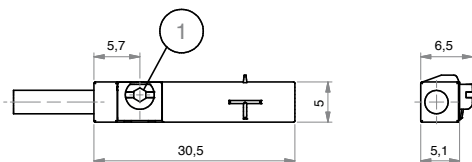

1= ECCENTRICO DI FISSAGGIO - FASTENING CLAMP

CABLAGGIO - WIRING

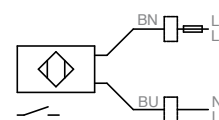

BN= MARRONE - BROWN
BU= BLU - BLUE

CONTATTO REED (CONNETTORE M8)

36.SEN07

REED CONTACT (M8 CONNECTOR)

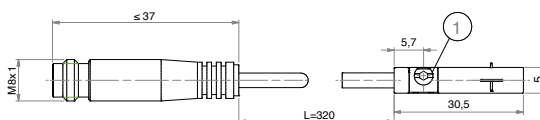

1= ECCENTRICO DI FISSAGGIO - FASTENING CLAMP

CABLAGGIO - WIRING

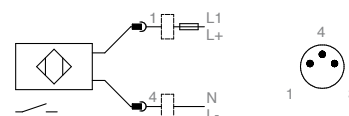

BN= MARRONE - BROWN
BU= BLU - BLUE

CONTATTO PNP (CONNETTORE M8)

36.SEN08

PNP CONTACT (M8 CONNECTOR)

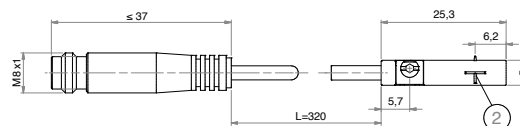

1= ECCENTRICO DI FISSAGGIO FASTENING CLAMP
2= SUPERFICIE ATTIVA SENSING FACE

CABLAGGIO - WIRING

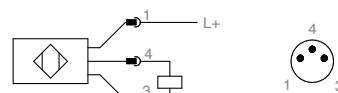

BN= MARRONE - BROWN
BU= BLU - BLUE

CONTATTO PNP (3 FILI)

36.SEN09

36.SEN09.L6

36.SEN09.L10

PNP CONTACT (3 WIRES)

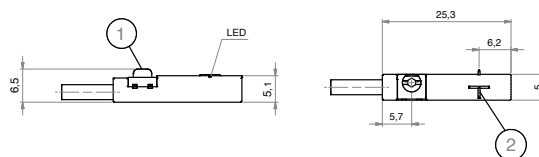

1= ECCENTRICO DI FISSAGGIO - FASTENING CLAMP
2= SUPERFICIE ATTIVA - SENSING FACE

CABLAGGIO - WIRING

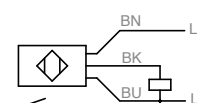

BK= NERO - BLACK
BN= MARRONE - BROWN
BU= BLU - BLUE

SERIE

O

SERIE

I

SERIE

H

SERIE

U

SERIE

P

SERIE

A

SERIE

ST

SERIE

K

SERIE

CN

SERIE

D

SERIE

W

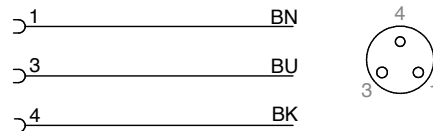
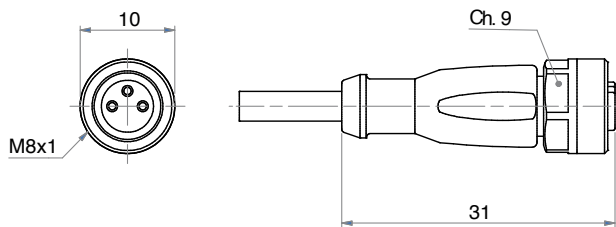
CAVO PROLUNGA (CONNETTORE M8)
EXTENSION CABLE (M8 CONNECTOR)

DIMENSIONI - DIMENSION

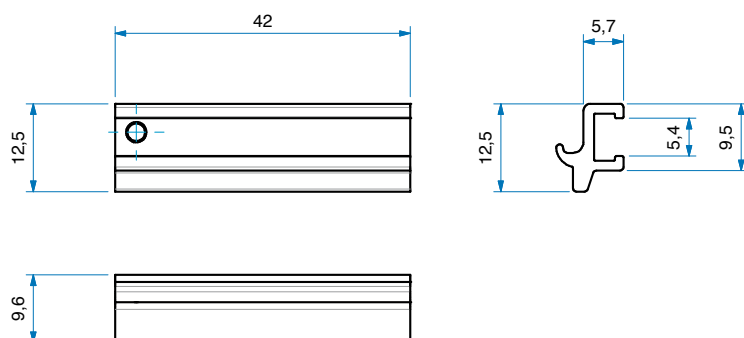
CODICE - CODE		36.CAV2.M8	36.CAV5.M8
Modello elettrico - Electrical design		AC/DC	AC/DC
Tensione di esercizio - Operating voltage	[V]	50 AC / 60 DC	50 AC / 60 DC
Capacità di corrente - Current rating	[A]	3	3
Modello - Travel speed		diritto - straight	diritto - straight
Temperatura ambiente - Ambient temperature	[°C]	-25...90 (cRUUs: max 50°C)	-25...90 (cRUUs: max 50°C)
Grado/Classe di protezione - Protection		IP 67 / IP 68 / IP 69K, III	IP 67 / IP 68 / IP 69K, III
Materiale corpo - Body material: Involucro - Housing		TPU arancione - orange TPU	TPU arancione - orange TPU
Guarnizione - Sealing		viton	viton
Materiale dado - Nut material		ottone nichelato - nickel-plated brass	ottone nichelato - nickel-plated brass
Coppia di serraggio per nodo nocciolo Tightening torque for knurled nut	[Nm]	0,3...0,5	0,3...0,5
Collegamento - Connection		cavo PUR - PUR cable / 2 m; 3 x 0,25 mm ² (32 x Ø 0,1 mm); Ø 3,7 mm; senza alogeno - alogen free	cavo PUR - PUR cable / 5 m; 3 x 0,25 mm ² (32 x Ø 0,1 mm); Ø 3,7 mm; senza alogeno - alogen free
Colore della guaina - Sheath colour		nero - black	nero - black

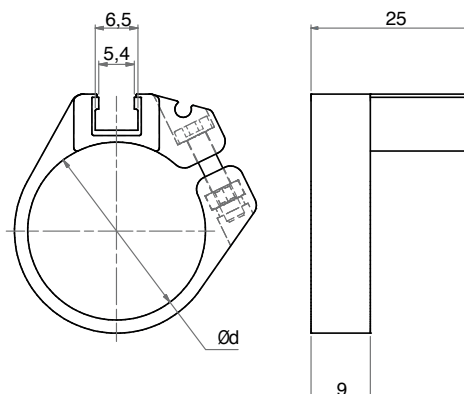
ADATTATORE PER CILINDRO SENZA STELO Ø 16-25-(Ø 32 C2-C3-C4)
SENSOR MOUNTIG FOR RODLESS CYLINDERS Ø 16-25-(Ø 32 C2-C3-C4)

ADATTATORE PER TUBO TONDO
SENSOR MOUNTING FOR ROUND TUBE

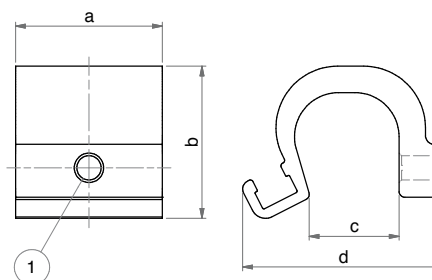
DIMENSIONI - DIMENSION

COD.		36.TIRM12	36.TIRM16	36.TIRM20	36.TIRM25	36.TIRM32	36.TIRM40
Alesaggio - Bore	[mm]	012	016	020	025	032	040
d	[mm]	12	16	20	25	32	40
Temperatura - Temperature	[°C]	0÷50					
Materiali - Materials		involucro - housing: POM ; supporto - fixture: alluminio - aluminium ; vite-screw: inox - stainless steel					

ADATTATORE PER TIRANTE
SENSOR MOUNTING FOR TIE ROD

1 = VITE DI FISSAGGIO FIXING SCREW (2,5)

DIMENSIONI - DIMENSIONS

COD.		36.TIR07	36.TIR11	36.TIR15	36.TIR20	36.TIR25
Gamma di morsetti - Clamping range	[mm]	5÷7	5÷11	9÷15	14÷20	
a		25	25	25	25	
b		21,6	22,8	25,9	31,1	
c		7,5	11,3	15,3	20,3	24,5
d		25,4	30,2	34,2	39,6	
Materiali involucro - Housing materials		alluminio - aluminium; vite-screw: inox-stainless steel				

SENSORI MAGNETICI

MAGNETIC SENSORS

CARATTERISTICHE - CHARACTERISTICS

CODICE - CODE		36.SEN26	36.SEN27	36.SEN28	36.SEN29
TIPO - TYPE		ELETTRONICO ELECTRONIC	ELETTRONICO ELECTRONIC	ELETTRONICO ELECTRONIC	ELETTRONICO ELECTRONIC
Modello elettrico - Electrical design		DC PNP	DC PNP	DC PNP	DC PNP
Funzione dell'uscita - Output		NO	NO	NO	NO
Tensione di esercizio - Operating voltage	[V]	10...30 DC	10...30 DC	10...30 DC	10...30 DC
Capacità di corrente - Current rating	[mA]	100	100	100	100
Sensibilità di reazione - Magnetic sensitivity	[mT]	2,8	2,8	2,8	2,8
Velocità di passaggio - Travel speed	[m/s]	> 10	> 10	> 10	> 10
Protezione da cortocircuito - Short-circuit proof		si - yes	si - yes	si - yes	si - yes
Protetto da inversione di polarità Reverse polarity protection		si - yes	si - yes	si - yes	si - yes
Resistente a sovraccarico - Overload protection		si - yes	si - yes	si - yes	si - yes
Caduta di tensione - Voltage drop	[V]	< 4,5	< 4,5	< 2,5	< 2,5
Isteresi - Hysteresis		< 0,12	< 0,12	< 1,5	< 1,5
Riproducibilità - Repeatability	[mm]	< 0,2	< 0,2	< 0,2	< 0,2
Corrente assorbita - Current consumption	[mA]	< 10	< 10	< 10	< 10
Frequenza di commutazione - Switching frequency	[Hz]	4.000	4.000	10.000	10.000
Temperatura ambiente - Ambient temperature	[°C]	-25...85	-25...85	-25...85	-25...85
Grado/Classe di protezione - Protection		IP65; IP67	IP65; IP67	IP65; IP67	IP65; IP67
Materiale involucro - Housing material		PA (poliammide - polyamide)			
Materiale eccentrico di fissaggio - Fastening clamp		inox - stainless steel			
Indicazione della funzione Stato di commutazione Function display Switching status	LED	giallo - yellow			
Collegamento - Connection		cavo PUR PUR cable / 2 m 2x0,14 mm ²	cavo PUR PUR cable / 0,3 m spina M8 m8 connector	cavo PUR PUR cable / 0,3 m spina M8 m8 connector	cavo PUR PUR cable / 2 m 3x0,14 mm ²
Peso - Weight	[g]	19	9,8	9,7	17,6

ADATTATORE DA CAVA T A CAVA C

36.ADATC

T-SLOT ADAPTER FOR C-SLOT

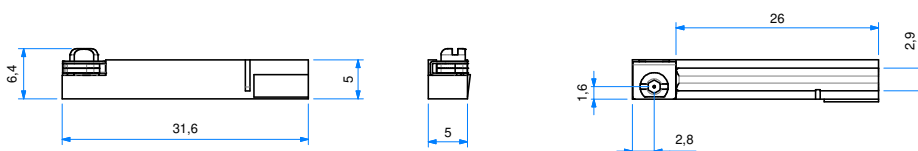

MATERIALE:
ZINCO PRESSOFUSO;
BRIGLIA DI FISSAGGIO: ACCIAIO INOX
MATERIAL:
DIECAST ZINC;
FIXING ELEMENT: STAINLESS STEEL

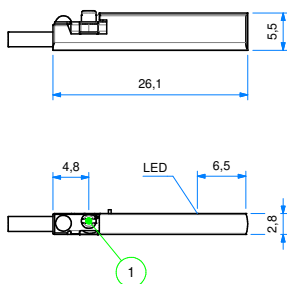
CONTATTO PNP (2 FILI)
PNP CONTACT (2 WIRES)

1= ECCENTRICO DI FISSAGGIO - FASTENING CLAMP

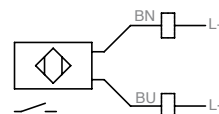
CABLAGGIO - WIRING

BN= MARRONE - BROWN
BU= BLU - BLUE

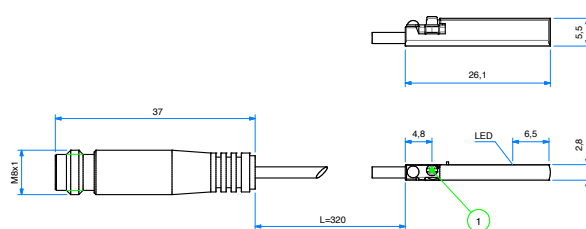
CONTATTO PNP (CONNETTORE M8)
PNP CONTACT (M8 CONNECTOR)

1= ECCENTRICO DI FISSAGGIO - FASTENING CLAMP

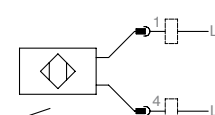
CABLAGGIO - WIRING

BN= MARRONE - BROWN
BU= BLU - BLUE

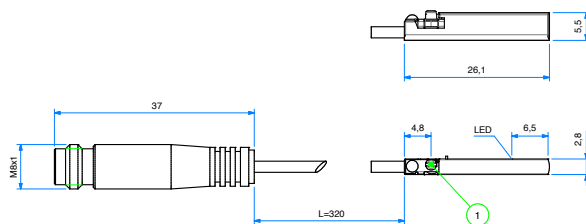
CONTATTO PNP (CONNETTORE M8)
PNP CONTACT (M8 CONNECTOR)

1= ECCENTRICO DI FISSAGGIO - FASTENING CLAMP

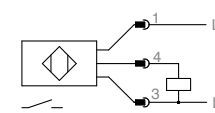
CABLAGGIO - WIRING

BN= MARRONE - BROWN
BU= BLU - BLUE

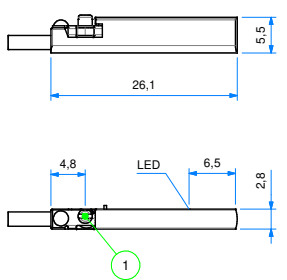
CONTATTO PNP (3 FILI)
PNP CONTACT (3 WIRES)

1= ECCENTRICO DI FISSAGGIO - FASTENING CLAMP

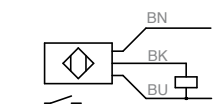
CABLAGGIO - WIRING

BK= NERO - BLACK
BN= MARRONE - BROWN
BU= BLU - BLUE

SENSORI MAGNETICI PER ZONE ASETTICHE E UMIDE

MAGNETIC SENSORS FOR ASEPTICAL AND WET AREAS

CARATTERISTICHE - CHARACTERISTICS

CODICE - CODE		36.SEN22	36.SEN23
TIPO - TYPE		ELETTRONICO - ELECTRONIC	ELETTRONICO - ELECTRONIC
Modello elettrico - Electrical design		DC PNP	DC PNP
Funzione dell'uscita - Output		N.O.	N.O.
Tensione di esercizio - Operating voltage	[V]	10...30 DC	10...30 DC
Capacità di corrente - Current rating	[mA]	100	100
Sensibilità di reazione - Magnetic sensitivity	[mT]	2,8	2,8
Velocità di passaggio - Travel speed	[m/s]	> 10	> 10
Protezione da cortocircuito - Short-circuit proof		si - yes	si - yes
Protetto da inversione di polarità - Reverse polarity protection		si - yes	si - yes
Resistente a sovraccarico - Overload protection		si - yes	si - yes
Caduta di tensione - Voltage drop	[V]	< 2,5	< 2,5
Isteresi - Hysteresis		1,5	1,5
Riproducibilità - Repeatability	[mm]	< 0,2	< 0,2
Corrente assorbita - Current consumption	[mA]	< 10	< 10
Ritardo alla disponibilità - Power-on delay time	[ms]	< 30	< 30
Frequenza di commutazione - Switching frequency	[Hz]	> 10.000	> 10.000
Temperatura ambiente - Ambient temperature	[°C]	-25...85	-25...85
Grado/Classe di protezione - Protection		IP 65/IP 67/IP 69K, III	IP 65/IP 67/IP 69K, III
Materiale involucro - Housing material		PA - (poliammide-polyamide)	PA - (poliammide-polyamide)
Materiale eccentrico di fissaggio - Fastening clamp		inox - stainless steel	inox - stainless steel
Indicazione della funzione Stato di commutazione Function display Switching status	LED	giallo - yellow	giallo - yellow
Collegamento - Connection		cavo PVC - PVC cable 3x0,14 mm ²	cavo PVC - PVC cable connettore M12 - M12 connector
Lunghezza cavo - Cable length		6 m	0,3 m
Peso - Weight	[g]	95,5	20,9

Accessori inclusi - Accessories included: Segnaposto in gomma, fascetta fermacavo - Rubber placeholder, cable clip

FASCETTA DI FISSAGGIO

36.TIRX

FIXING CLAMP

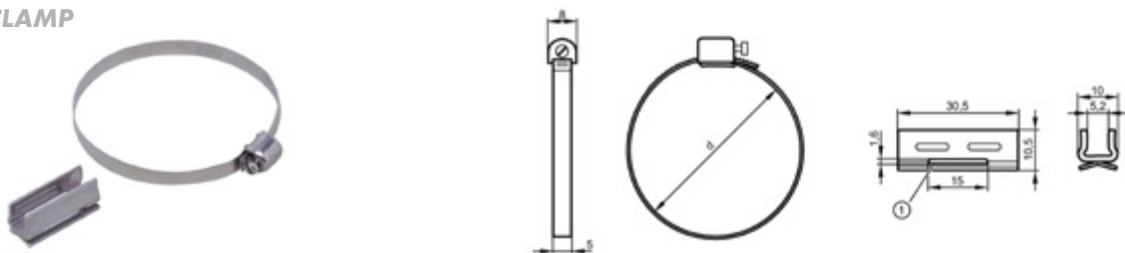

DIMENSIONI DIMENSIONS

COD.	36.TIRX08.12	36.TIRX16.20	36.TIRX25.32	36.TIRX40	36.TIRX50	36.TIRX63	36.TIRX80	36.TIRX100
Ø	008-012	016-020	025-032	040	050	063	080	100
d [mm]	11÷19	18÷29	28÷39	38÷49	48÷59	58÷69	78÷89	98÷109
Materiale fascetta Fixing clamp material	acciaio inox AISI 303 - AISI 303 stainless steel							
Materiale adattatore Adapter material	acciaio inox AISI 304 - AISI 304 stainless steel							

CONTATTO PNP (3 FILI)
PNP CONTACT (3 WIRES)

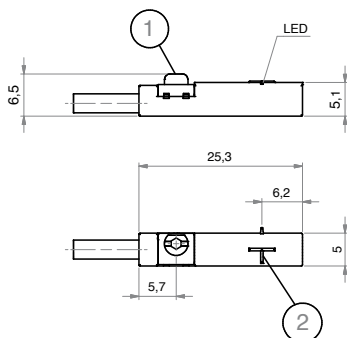
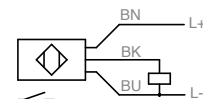

1= ECCENTRICO DI FISSAGGIO - FASTENING CLAMP
2= SUPERFICIE ATTIVA - SENSING FACE

CABLAGGIO - WIRING

BK= NERO - BLACK
BN= MARRONE - BROWN
BU= BLU - BLUE

CONTATTO PNP (CONNETTORE M12)
PNP CONTACT (M12 CONNECTOR)

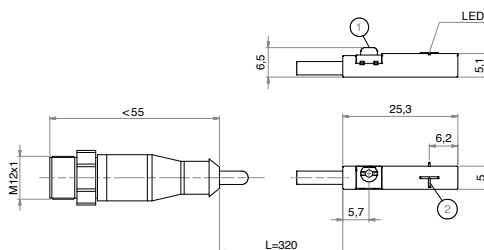
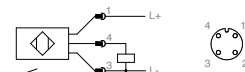
1= ECCENTRICO DI FISSAGGIO - FASTENING CLAMP
2= SUPERFICIE ATTIVA - SENSING FACE

CABLAGGIO - WIRING

BK= NERO - BLACK
BN= MARRONE - BROWN
BU= BLU - BLUE

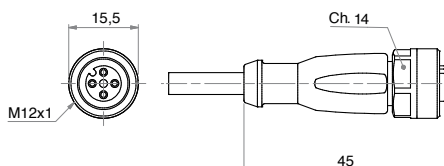
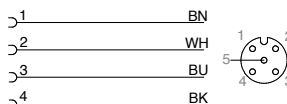
CAVO PROLUNGA (CONNETTORE M12)
EXTENSION CABLE (M12 CONNECTOR)

CABLAGGIO - WIRING

BK= NERO - BLACK
BN= MARRONE - BROWN
BU= BLU - BLUE
WH= BIANCO - WHITE

DIMENSIONI - DIMENSIONS	36.CAVX2. M12	36.CAVX5. M12
Modello elettrico - Electrical design	AC/DC	AC/DC
Tensione di esercizio - Operating voltage	[V] 250 AC / 300 DC	250 AC / 300 DC
Capacità di corrente - Current rating	[A] 4	4
Modello - Design	diritto - straight	diritto - straight
Temperatura ambiente - Ambient temperature	[°C] -25...90 (cRUus:max 50°C)	-25...90 (cRUus:max 50°C)
Grado/Classe di protezione - Protection	IP 67 / IP 68 / IP 69K, II	IP 67 / IP 68 / IP 69K, II
Materiale corpo - Body material: Involucro - Housing	TPU arancione - orange TPU	TPU arancione - orange TPU
Guarnizione - Sealing	viton	viton
Materiale dado - Nut material	ottone nichelato - nickel-plated brass	ottone nichelato - nickel-plated brass
Coppia di serraggio per nodo nocciolo Tightening torque for knurled nut	[Nm] 0,6...1,5	0,6...1,5
Collegamento - Connection	cavo PUR - PUR cable / 2 m; 4 x 0,34 mm ² (42 x ø 0,1 mm); ø 4,9 mm; senza alogeno - alogen free	cavo PUR - PUR cable / 5 m; 4 x 0,34 mm ² (42 x ø 0,1 mm); ø 4,9 mm; senza alogeno - alogen free
Colore della guaina - Sheath colour	nero - black	nero - black

SENSORI MAGNETICI ATEX

ATEX MAGNETIC SENSORS

CARATTERISTICHE - CHARACTERISTICS		36.SEN32A.L6	36.SEN33A
TIPO - TYPE		ELETTRONICO - ELECTRONIC	ELETTRONICO - ELECTRONIC
Modello elettrico - Electrical design		DC PNP	DC PNP
Funzione dell'uscita - Output		NO	NO
Tensione di esercizio - Operating voltage	[V]	10...30 DC	10...30 DC
Capacità di corrente - Current rating	[mA]	100	100
Sensibilità di reazione - Magnetic sensitivity	[mT]	2	2,8
Velocità di passaggio - Travel speed	[m/s]	> 10	> 10
Protezione da cortocircuito - Short-circuit proof		si - yes	si - yes
Protetto da inversione di polarità - Reverse polarity protection		si - yes	si - yes
Resistente a sovraccarico - Overload protection		si - yes	si - yes
Caduta di tensione - Voltage drop	[V]	< 2,5	< 2,5
Isteresi - Hysteresis		1	< 1,5
Riproducibilità - Repeatability	[mm]	< 0,2	< 0,2
Corrente assorbita - Current consumption	[mA]	< 10	< 10
Ritardo alla disponibilità - Power-on delay time	[ms]	< 30	< 30
Frequenza di commutazione - Switching frequency	[Hz]	6.000	10.000
Temperatura ambiente - Ambient temperature	[°C]	-20...60	-25...60
Grado/Classe di protezione - Protection		IP 65/IP 67	IP 65/IP 67
Contrassegno - Marking of the unit		II 3D Ex tc IIIC T125°C Dc X II 3G Ex nA IIC T4 Gc X	II 3D Ex tc IIIC T125°C Dc X
Materiale involucro - Housing material		PA (poliammide-polyamide)	PA (poliammide-polyamide)
Materiale eccentrico di fissaggio - Fastening clamp		inox - stainless steel	inox - stainless steel
Indicazione della funzione Stato di commutazione Function display Switching status	LED	giallo - yellow	giallo - yellow
Collegamento - Connection		cavo PVC - PVC cable 3x0,14 mm ²	cavo PVC - PVC cable connettore M12 - M12 connector
Lunghezza cavo - Cable length		6 m	0,3 m
Peso - Weight	[g]	103,3	52,4

Accessori inclusi - Accessories included: Segnaposto in gomma, fascetta fermacavo - Rubber placeholder, cable clip

36.TIRX

FASCETTA DI FISSAGGIO

FIXING CLAMP

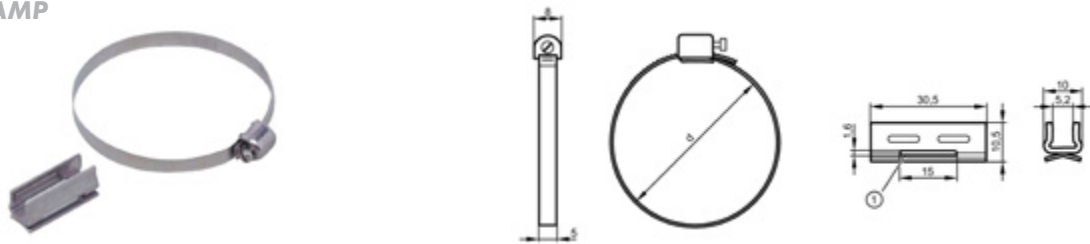

DIMENSIONI DIMENSIONS

COD.	36.TIRX08.12	36.TIRX16.20	36.TIRX25.32	36.TIRX40	36.TIRX50	36.TIRX63	36.TIRX80	36.TIRX100
Ø	008-012	016-020	025-032	040	050	063	080	100
d [mm]	11÷19	18÷29	28÷39	38÷49	48÷59	58÷69	78÷89	98÷109
Materiale fascetta Fixing clamp material	acciaio inox AISI 303 - AISI 303 stainless steel							
Materiale adattatore Adapter material	acciaio inox AISI 304 - AISI 304 stainless steel							



36.SEN32A.L6

CONTATTO PNP (3 FILI)

PNP CONTACT (3 WIRES)



- 1= ECCENTRICO DI FISSAGGIO - FASTENING CLAMP
- 2= SUPERFICIE ATTIVA - SENSING FACE

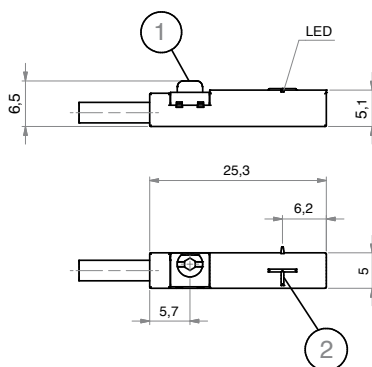

CABLAGGIO - WIRING

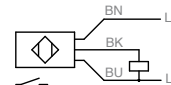

- BK= NERO - BLACK
- BN= MARRONE - BROWN
- BU= BLU - BLUE

CONTATTO PNP (CONNETTORE M12)

PNP CONTACT (M12 CONNECTOR)



- 1= ECCENTRICO DI FISSAGGIO - FASTENING CLAMP
- 2= SUPERFICIE ATTIVA - SENSING FACE

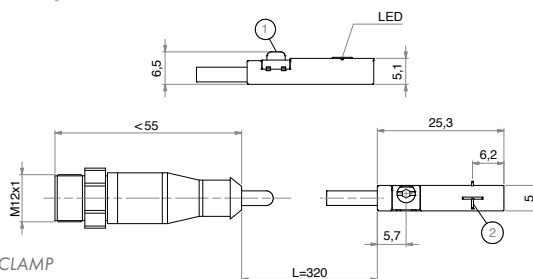

CABLAGGIO - WIRING

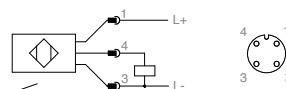

- BK= NERO - BLACK
- BN= MARRONE - BROWN
- BU= BLU - BLUE

CAVO PROLUNGA (CONNETTORE M12)

EXTENSION CABLE (M12 CONNECTOR)

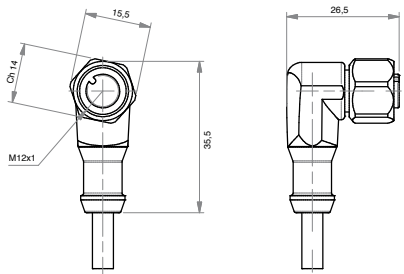

CABLAGGIO - WIRING

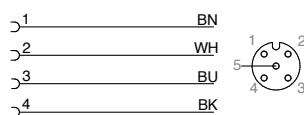

- BK= NERO - BLACK
- BN= MARRONE - BROWN

- BU= BLU - BLUE
- WH= BIANCO - WHITE



36.CAVA

SENSORI MAGNETICI

MAGNETIC SENSORS

CARATTERISTICHE - CHARACTERISTICS

CODICE - CODE	36.SEN01	
TIPO - TYPE	REED	
Modello elettrico - Electrical design	AC/DC	
Funzione dell'uscita - Output	NO	
Tensione di esercizio - Operating voltage	[V]	3...110 AC/DC
Corrente di commutazione - Switching current	[mA]	300
Potenza max - Switching power max	[W]	10
Caduta di tensione - Voltage drop	[V]	< 3
Tempo di commutazione - Make time	[ms]	0,5
Tempo di riapertura - Fall Time	[ms]	0,1
Temperatura ambiente - Ambient temperature	[°C]	-10...70
Frequenza di commutazione - Switching frequency	[Hz]	500
Protetto da inversione di polarità - Reverse polarity protection	si - yes	
Grado di protezione - Protection	IP67	
Materiale involucro - Housing material	PA+AISI 303	
Indicazione della funzione Stato di commutazione - Function display Switching status	LED	giallo - yellow
Collegamento - Connection	Cavo PVC - PVC cable 2,5m / 2x0,25mm ²	

Accessori inclusi: Staffa di fissaggio - Accessories included: Fixing bracket

SERIE M Questi sensori possono essere utilizzati solo sulle pinze M20 e M50
 These sensors can be used only in grippers M20 and M50

CONTATTO REED (2 FILI)

36.SEN01

REED CONTACT (2 WIRES)

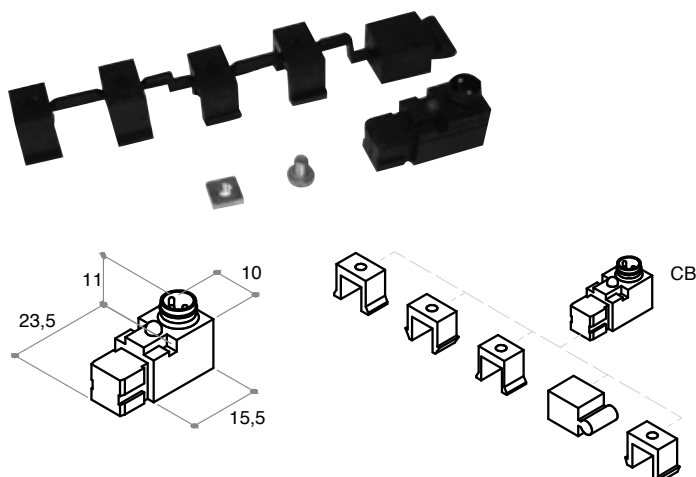

CABLAGGIO - WIRING

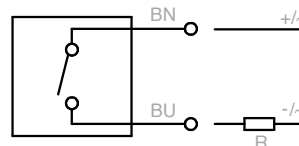

BN= MARRONE - BROWN

BU= BLU - BLUE

incluso cavo di collegamento - connection cable included L=2500mm