

INDEX / INDICE

(*) ATEX versions see / Versioni ATEX vedi P. B-113

VALVES AND SOLENOID VALVES SERIES NAMUR 3/2 / VALVOLE ED ELETTROVALVOLE SERIE NAMUR 3/2

pag. B-95

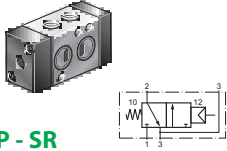

(*) **NM32V1P - SR**
 SINGLE PNEUMATIC PILOT - SPRING RETURN
 COMANDO PNEUMATICO - MOLLA MECCANICA

pag. B-96

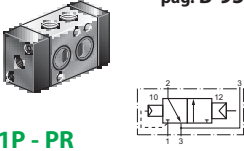

NM32V1P - PR
 SINGLE PNEUMATIC PILOT - INTERNAL PRESSURE RETURN
 COMANDO PNEUMATICO - MOLLA PNEUMATICA

pag. B-96

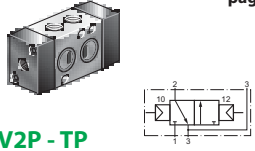

(*) **NM32V2P - TP**
 DOUBLE PNEUMATIC PILOT
 DOPPIO COMANDO PNEUMATICO

pag. B-96

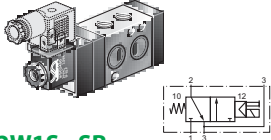

(*) **NM32W1S - SR -**
 SOLENOID VALVE - SPRING RETURN
 COMANDO ELETTROPNEUMATICO - MOLLA MECCANICA

pag. B-97

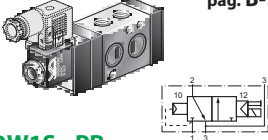

NM32W1S - PR -
 SOLENOID VALVE - INTERNAL PRESSURE RETURN
 COMANDO ELETTROPNEUMATICO - MOLLA PNEUMATICA

pag. B-97

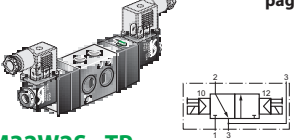

(*) **NM32W2S - TP -**
 DOUBLE SOLENOID VALVE
 DOPPIO COMANDO ELETTROPNEUMATICO

(*) ATEX versions see / Versioni ATEX vedi P. B-113

VALVES AND SOLENOID VALVES SERIES NAMUR 5/2 / VALVOLE ED ELETTROVALVOLE SERIE NAMUR 5/2

pag. B-97

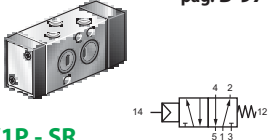

(*) **NM52V1P - SR**
 SINGLE PNEUMATIC PILOT - SPRING RETURN
 COMANDO PNEUMATICO - MOLLA MECCANICA

pag. B-98

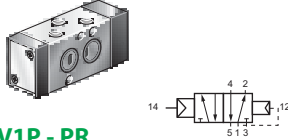

NM52V1P - PR
 SINGLE PNEUMATIC PILOT - INTERNAL PRESSURE RETURN
 COMANDO PNEUMATICO - MOLLA PNEUMATICA

pag. B-98

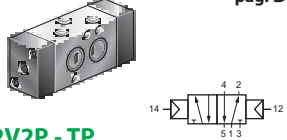

(*) **NM52V2P - TP**
 DOUBLE PNEUMATIC PILOT
 DOPPIO COMANDO PNEUMATICO

pag. B-99

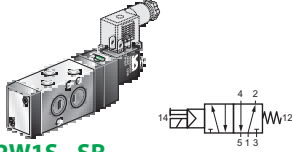

(*) **NM52W1S - SR -**
 SOLENOID VALVE - SPRING RETURN
 COMANDO ELETTROPNEUMATICO - MOLLA MECCANICA

pag. B-99

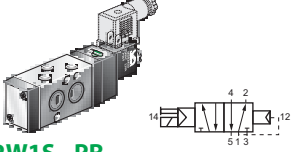

NM52W1S - PR -
 SOLENOID VALVE - INTERNAL PRESSURE RETURN
 COMANDO ELETTROPNEUMATICO - MOLLA PNEUMATICA

pag. B-99

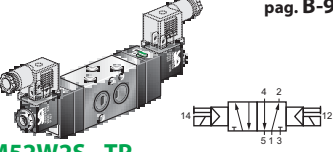

(*) **NM52W2S - TP -**
 DOUBLE SOLENOID VALVE
 DOPPIO COMANDO ELETTROPNEUMATICO



BUILDING FEATURES / CARATTERISTICHE COSTRUTTIVE

VESTA "NAMUR" valves are available in the 3/2 and 5/2 versions, with different forms of actuation (i.e. solenoid / pilot etc).

This series of valves present a high nominal air flow and no environmental contact between the namur valve and the actuator being switched (See Fig. **A**). These namur valves have a high working frequency and can be used with lubricated or non-lubricated air (See Fig. **B**), thanks to a spool made of a light alloy aluminium, nickel treated by "Niploy Process" (See Fig. **C**) to give the surface a smooth finish. The self lubricating lip rubber seals which the spool runs in, assures the valves of a long lasting durable life span.

Le valvole ed elettrovalvole VESTA della serie **NAMUR** funzionano secondo il principio del distributore a cassetto bilanciato (vedi fig. **1 e 2**).

La serie, realizzata nelle funzioni 3/2 e 5/2, viene fornita con più sistemi di azionamento e riposizionamento.

Le caratteristiche fondamentali sono: grande portata d'aria, ermeticità di funzionamento verso l' ambiente di lavoro nei modelli bistabili e in quelli con ritorno a molla pneumatica (**A**), alta velocità di scambio, possibilità di funzionamento continuo privo di lubrificazione (**B**) ottenuto con l'impiego di materiali particolari come, ad esempio, la spola realizzata in lega leggera con trattamento Niploy Process che le conferisce notevole durezza superficiale e caratteristiche autolubrificanti (**C**), e le guarnizioni in elastomero nitrilico con profilo a labbro antiusura.

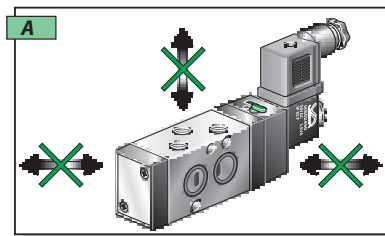

Protected against working environment.
Protezione verso l'ambiente di lavoro.

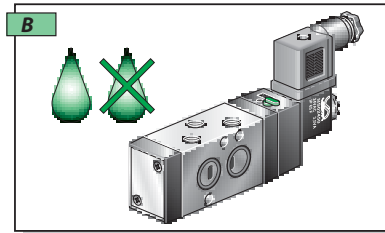

Possibility of operating continuously without lubrication.
Possibilità di funzionamento continuo privo di lubrificazione.

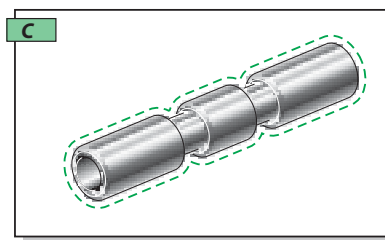

Light alloy spool with Niploy Process treated surface.
Spola in lega leggera con trattamento speciale Niploy Process.

SET . 1/4 SG

SEALS KIT
KIT GUARNIZIONI DI RICAMBIO

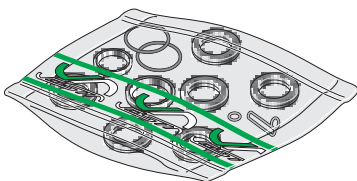

Seals kit code - *Codice del kit*

SET 1 1/4 SG for NAMUR **mono-stable** valves - *per valvole NAMUR.*

SET 2 1/4 SG for NAMUR **bi-stable** valves - *per valvole NAMUR.*

Example / *Esempio*: **NM32W15-SR -02400** → **SET 1 1/4 SG** **NM32W25-TP -02400** → **SET 2 1/4 SG**

In the example here below, when the valve **NM52W1S-PR-02450** (see the draw) stands in the normal position, ports **4 - 5** and **1 - 2** are connected and the position is kept thanks to the pressure assured to the smallest piston (right side of the valve).

When the valve is actuated, the same pressure is fed to the biggest piston. It's bigger surface create a force which allows to the spool to move and therefore to connect ports **4 - 1** and **2 - 3**. In the mechanical spring version, the valve is kept in the normal position by a mechanical spring. In the bistable versions, the position of the valve remains in its last switched state.

*Il principio di funzionamento dei distributori 3/2 e 5/2 (nell'esempio l'elettrovalvola **NM52W1S-PR-02450** con comando elettropneumatico e riposizionamento a molla pneumatica) consiste nel mantenere costantemente in pressione il pistone di riposizionamento (fig. 1), utilizzando la fonte d'aria compressa presente nel condotto di alimentazione **1**, collegando le vie **1 - 2** e **4 - 5**.*

*L'eccitazione del solenoide mette in comunicazione il condotto **1** con la camera dove è alloggiato il pistone di comando. Quest'ultimo, avendo un'area di spinta maggiore del pistone di riposizionamento, sposta la spola in modo tale da collegare i canali **1 - 4** e **2 - 3** (fig. 2).*

Diseccitando il solenoide si ripristina la posizione iniziale. Nel sistema dotato di riposizionamento con molla meccanica il funzionamento è analogo, mentre nei sistemi bistabili (doppio comando elettropneumatico o doppio comando pneumatico) in assenza di segnale rimangono i collegamenti formatisi nell'ultimo azionamento.

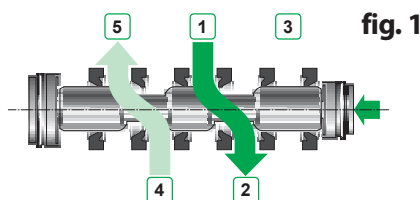
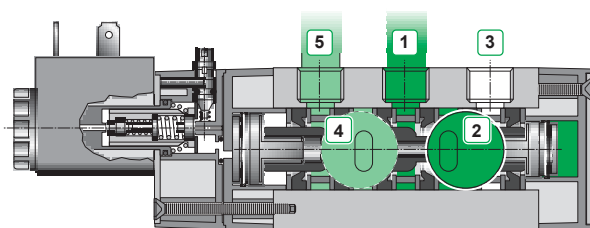

NORMAL POSITION / POSIZIONE A RIPOSO

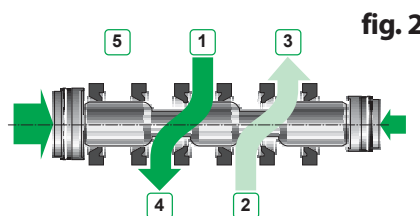
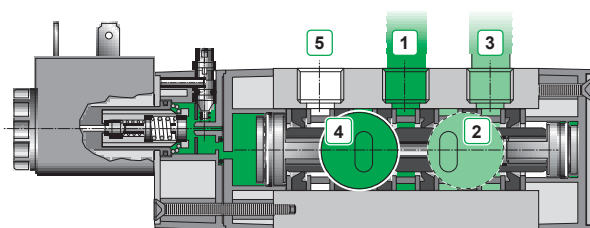

ACTUATED POSITION / POSIZIONE DI LAVORO

MANUAL OVERRIDING / AZIONAMENTO COMANDO MANUALE

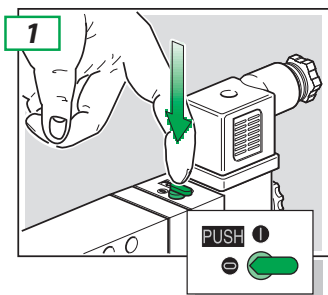

Push to actuated valve without locking. **Relise the button to get back to normal position.**

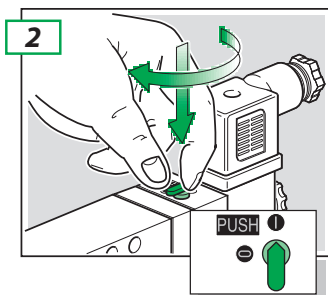

To active the valve permanently push the M/O (manual override) and rotate clockwise 90°. **To return to normal position, push the M/O again and turn 90° anti-clockwise.**

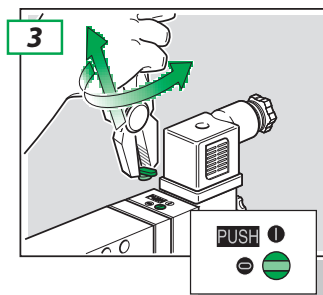

Should the M/O no longer be required, then turn the M/O anticlockwise until it breaks off.

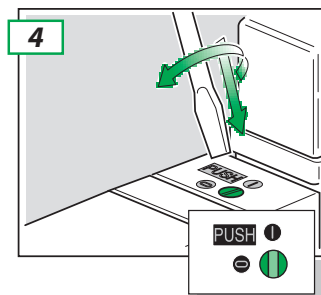

Should the M/O be required after breaking off, then a screwdriver may be used.

*Per azionare la valvola, durante la fase di collaudo con pressione in linea senza collegamento elettrico, premere la leva del comando manuale. **Rilasciare per ripristinare la condizione di riposo.***

*Per azionare la valvola in modo permanente premere la leva del comando manuale e ruotare in senso orario sino alla posizione 1. **Ruotare in senso antiorario per ripristinare la condizione di riposo.***

Terminato il collaudo ruotare in senso antiorario la leva sino alla rottura.

Per interventi successivi sul comando manuale usare un adeguato cacciavite ed operare come al punto 1 o 2.



SERIE NM

TECHNICAL FEATURES / CARATTERISTICHE TECNICHE

COMMON TECHNICAL FEATURES NM

Fixing	N° 2 Holes Ø 5,3	Medium	Filtered air
Port connections	G 1/4	Reference temperature	+20 °C
Flow section	Ø 8 mm	Reference pressure	6 bar
Environment temperature range	-10 °C / +50 °C	Nominal air flow	1080 NI/min
Temperature range of medium	0 °C / +40 °C	Fluid conductance "C"	4,34 NI/s bar
Lubrication	Not required	Critical pressure ratio "b"	0,212

PNEUMATIC VALVES FEATURES NM

NM32V1P - SR	Nominal max frequency	10 Hz
NM52V1P - SR	Operating pressure range	2,5 ÷ 10 bar

NM32V1P - PR	Nominal max frequency	20 Hz
NM52V1P - PR	Operating pressure range	2,5 ÷ 10 bar

NM32V2P - TP	Nominal max frequency	30 Hz
NM52V2P - TP	Operating pressure range	1,5 ÷ 10 bar

SOLENOID VALVES FEATURES NM

	AC	DC
NM32W1S - SR	Nominal max frequency	11 Hz
NM52W1S - SR	Response time - switch ON	19 ms
	Response time - switch OFF	35 ms
	Operating pressure range	2,5 ÷ 10 bar

	AC	DC
NM32W1S - PR	Nominal max frequency	16 Hz
NM52W1S - PR	Response time - switch ON	18 ms
	Response time - switch OFF	33 ms
	Operating pressure range	2,5 ÷ 10 bar

NM32W2S - TP	Nominal max frequency	27 Hz
NM52W2S - TP	Response time - switch ON	11 ms
	Response time - switch OFF	11 ms
	Operating pressure range	1,5 ÷ 10 bar

For electrical features solenoid pilot NAMUR serie pp. B-36 ÷ B-37.

CARATTERISTICHE TECNICHE COMUNI NM

Fissaggio	N° 2 fori Ø 5,3	Fluido	Aria filtrata
Connessioni	G 1/4	Temperatura nominale	+20 °C
Diametro nominale	Ø 8 mm	Pressione nominale	6 bar
Temperatura ambiente	-10 °C / +50 °C	Portata nominale	1080 NI/min
Temperatura fluido	0 °C / +40 °C	Valore conduttanza "C"	4,34 NI/s bar
Lubrificazione	Non necessaria	Rapporto critico delle pressioni "b"	0,212

CARATTERISTICHE VALVOLE PNEUMATICHE NM

NM32V1P - SR	Frequenza max nominale	10 Hz
NM52V1P - SR	Pressione di esercizio	2,5 ÷ 10 bar

NM32V1P - PR	Frequenza max nominale	20 Hz
NM52V1P - PR	Pressione di esercizio	2,5 ÷ 10 bar

NM32V2P - TP	Frequenza max nominale	30 Hz
NM52V2P - TP	Pressione di esercizio	1,5 ÷ 10 bar

CARATTERISTICHE ELETTROVALVOLE NM

	AC	DC
NM32W1S - SR	Frequenza max nominale	11 Hz
NM52W1S - SR	Tempo medio di risposta in eccitazione	19 ms
	Tempo medio di risposta in diseccitazione	35 ms
	Pressione di esercizio	2,5 ÷ 10 bar

	AC	DC
NM32W1S - PR	Frequenza max nominale	16 Hz
NM52W1S - PR	Tempo medio di risposta in eccitazione	18 ms
	Tempo medio di risposta in diseccitazione	33 ms
	Pressione di esercizio	2,5 ÷ 10 bar

NM32W2S - TP	Frequenza max nominale	27 Hz
NM52W2S - TP	Tempo medio di risposta in eccitazione	11 ms
	Tempo medio di risposta in diseccitazione	11 ms
	Pressione di esercizio	1,5 ÷ 10 bar

Caratteristiche elettriche bobina per elettrovalvole serie NAMUR vedi pp. B-36 ÷ B-37.

VALVE / VALVOLA 3/2
 SINGLE PNEUMATIC PILOT - SPRING RETURN
 COMANDO PNEUMATICO - RIPOSIZIONAMENTO A MOLLA MECCANICA

NM32V1P - SR

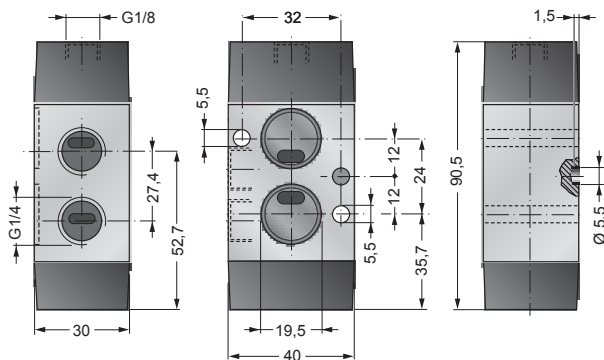
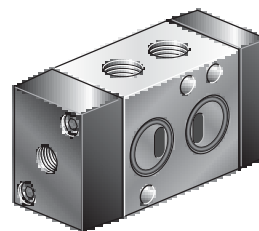

SIMBOL / SIMBOLO

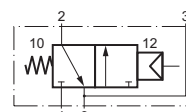

DIAGRAMS / DIAGRAMMI

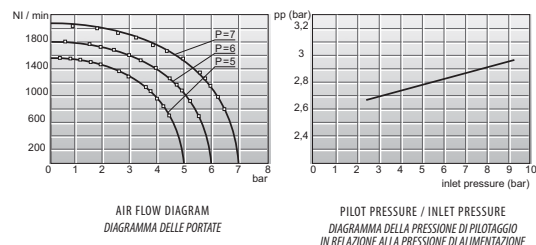

VALVE / VALVOLA 3/2
 SINGLE PNEUMATIC PILOT - INTERNAL PRESSURE RETURN
 COMANDO PNEUMATICO - RIPOSIZIONAMENTO A MOLLA PNEUMATICA

NM32V1P - PR

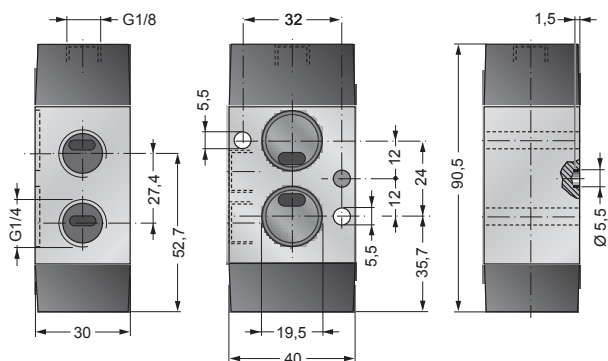
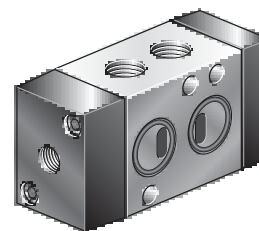

SIMBOL / SIMBOLO

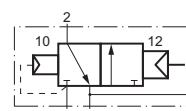

DIAGRAMS / DIAGRAMMI

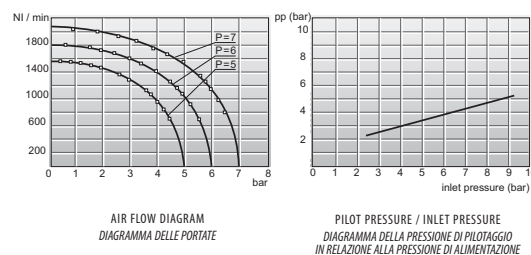



NM32V2P - TP

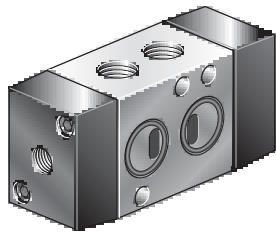

SIMBOL / SIMBOLO

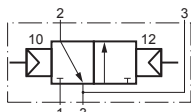

DIAGRAMS / DIAGRAMMI

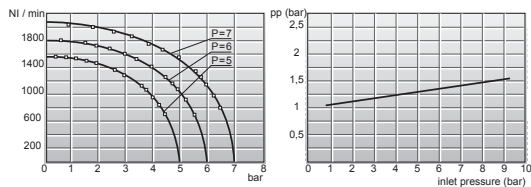

AIR FLOW DIAGRAM
DIAGRAMMA DELLE PORTATE

PILOT PRESSURE / INLET PRESSURE
DIAGRAMMA DELLA PRESSIONE DI PILOTAGGIO
IN RELAZIONE ALLA PRESSIONE DI ALIMENTAZIONE

VALVE / VALVOLA 3/2 DOUBLE PNEUMATIC PILOT DOPPIO COMANDO PNEUMATICO

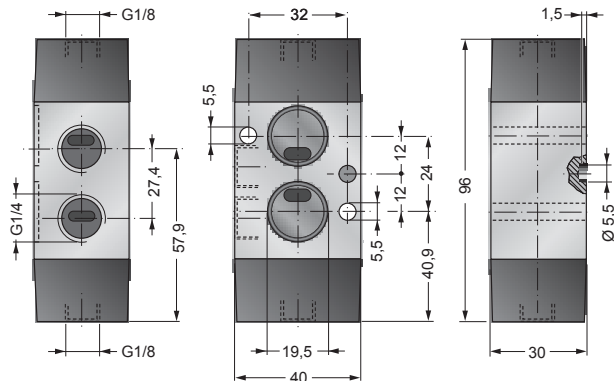

NM32W1S - .R -

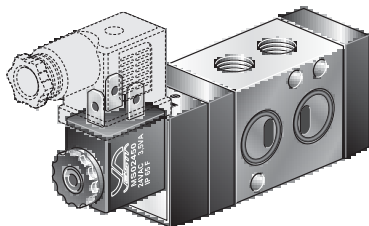

SIMBOLS / SIMBOLI

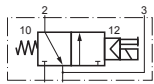

NM32W1S-SR-.....

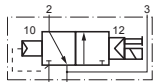

NM32W1S-PR-.....

DIAGRAM / DIAGRAMMA

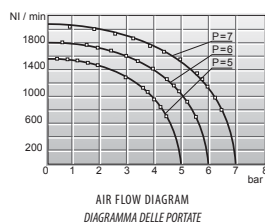

AIR FLOW DIAGRAM
DIAGRAMMA DELLE PORTATE

VALVE / VALVOLA 3/2 SOLENOID VALVE COMANDO ELETTROPNEUMATICO

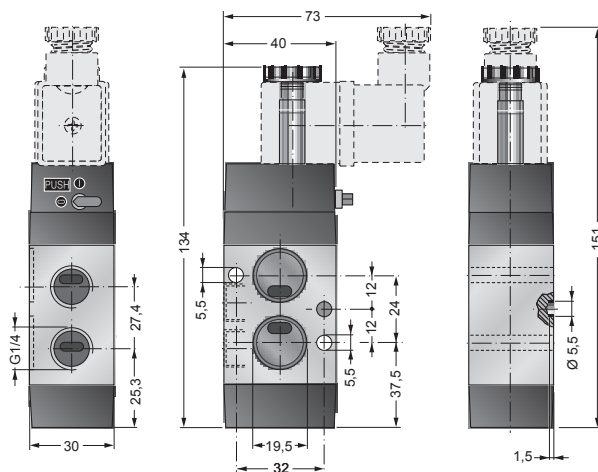

CODES / CODICI

Ordination code Codice ordinazione	Voltage Tensione
NM32W1S - .R - 00000	No coil / Senza solenoide
NM32W1S - .R - 01200	12 V DC
NM32W1S - .R - 02400	24 V DC
NM32W1S - .R - 02450	24 V 50/60Hz AC
NM32W1S - .R - 11550	115 V 50/60Hz AC
NM32W1S - .R - 22050	220 V 50/60Hz AC

VALVE / VALVOLA 3/2
DOUBLE SOLENOID VALVE
DOPPIO COMANDO ELETTROPNEUMATICO

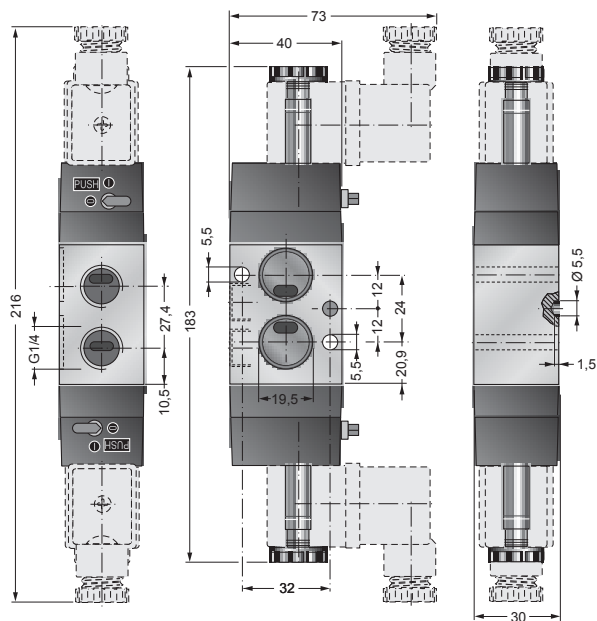

NM32W2S - TP -

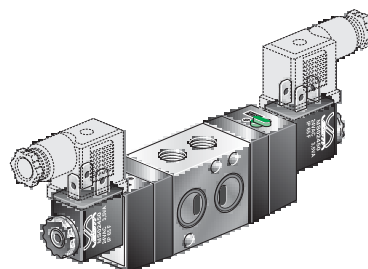

SIMBOL / SIMBOLO

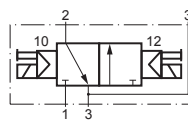
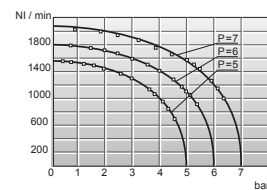

DIAGRAM / DIAGRAMMA



AIR FLOW DIAGRAM
DIAGRAMMA DELLE PORTATE

CODES / CODICI

**Ordination code
Codice ordinazione**

- NM32W2S - TP - 00000
- NM32W2S - TP - 01200
- NM32W2S - TP - 02400
- NM32W2S - TP - 02450
- NM32W2S - TP - 11550
- NM32W2S - TP - 22050

**Voltage
Tensione**

- No coils / Senza solenoidi
- 12 V DC
- 24 V DC
- 24 V 50/60Hz AC
- 115 V 50/60Hz AC
- 220 V 50/60Hz AC

VALVE / VALVOLA 5/2
SINGLE PNEUMATIC PILOT - SPRING RETURN
COMANDO PNEUMATICO - RIPOSIZIONAMENTO A MOLLA MECCANICA

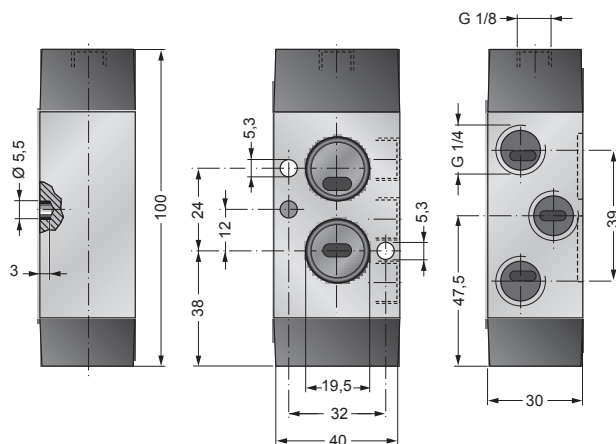

NM52V1P - SR

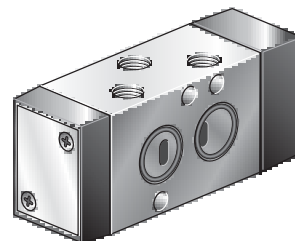

SIMBOL / SIMBOLO

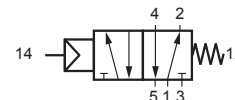

DIAGRAMS / DIAGRAMMI

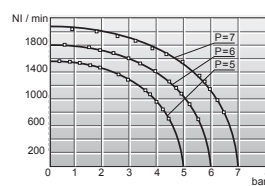

AIR FLOW DIAGRAM
DIAGRAMMA DELLE PORTATE

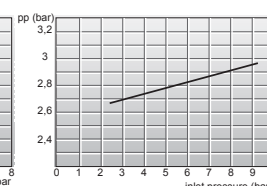

PILOT PRESSURE / INLET PRESSURE
DIAGRAMMA DELLA PRESSIONE DI PILOTAGGIO
IN RELAZIONE ALLA PRESSIONE DI ALIMENTAZIONE

NM52V1P - PR

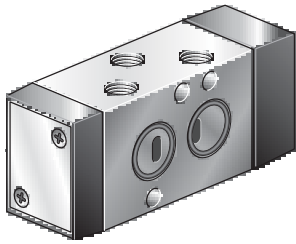

SIMBOL / SIMBOLO

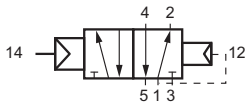

DIAGRAMS / DIAGRAMMI

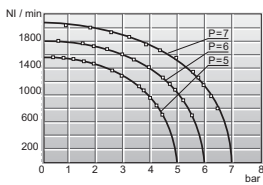

AIR FLOW DIAGRAM
DIAGRAMMA DELLE PORTATE

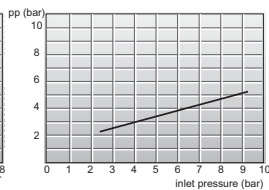

PILOT PRESSURE / INLET PRESSURE
DIAGRAMMA DELLA PRESSIONE DI PILOTAGGIO
IN RELAZIONE ALLA PRESSIONE DI ALIMENTAZIONE

VALVE / VALVOLA 5/2 SINGLE PNEUMATIC PILOT - INTERNAL PRESSURE RETURN COMANDO PNEUMATICO - RIPOSIZIONAMENTO A MOLLA PNEUMATICA

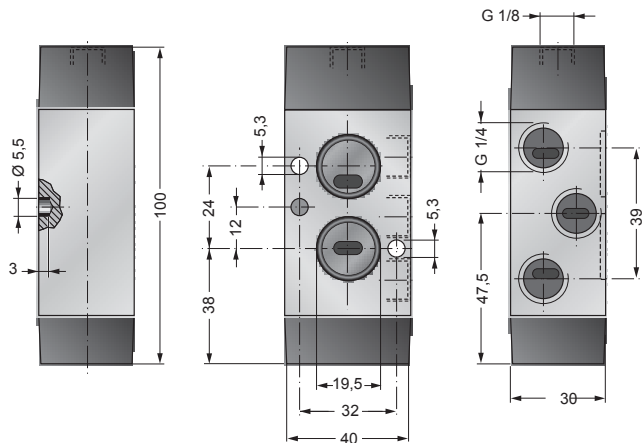

NM52V2P - TP

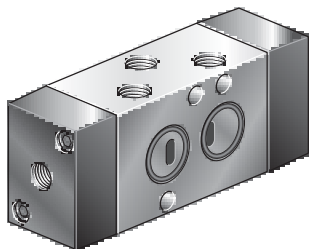

SIMBOL / SIMBOLO

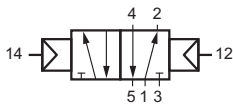

DIAGRAMS / DIAGRAMMI

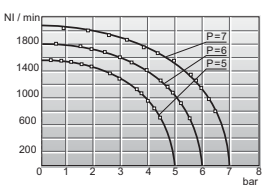

AIR FLOW DIAGRAM
DIAGRAMMA DELLE PORTATE

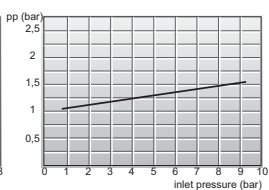

PILOT PRESSURE / INLET PRESSURE
DIAGRAMMA DELLA PRESSIONE DI PILOTAGGIO
IN RELAZIONE ALLA PRESSIONE DI ALIMENTAZIONE

VALVE / VALVOLA 5/2 DOUBLE PNEUMATIC PILOT DOPPIO COMANDO PNEUMATICO

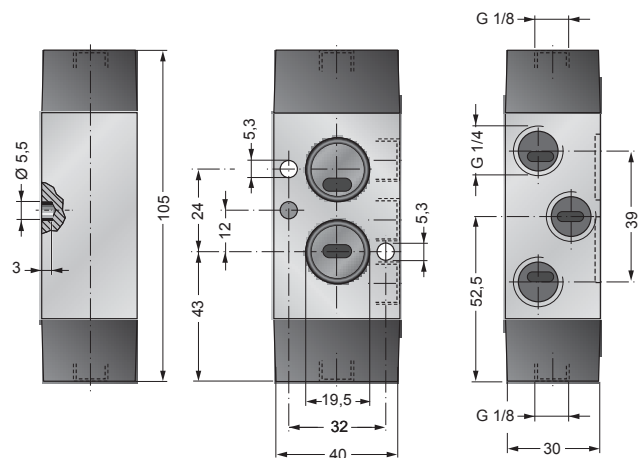

VALVE / VALVOLA 5/2
 SOLENOID VALVE - SPRING RETURN
 COMANDO ELETTROPNEUMATICO - RIPOSIZIONAMENTO A MOLLA MECCANICA

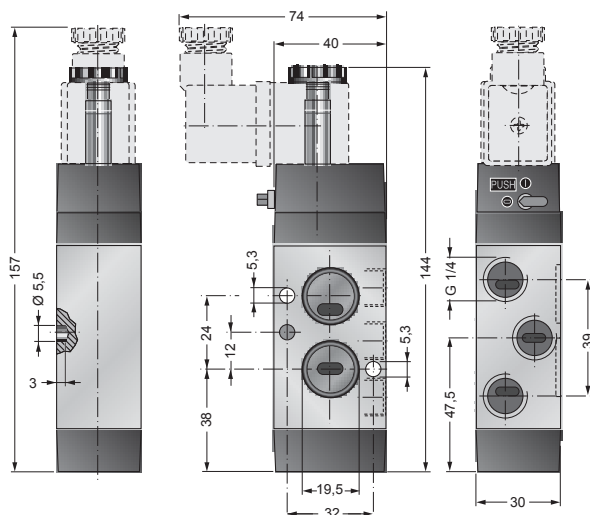

NM52W1S - .R -.....

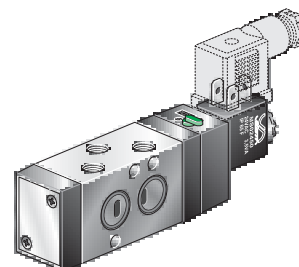

SIMBOLS / SIMBOLI

DIAGRAM / DIAGRAMMA

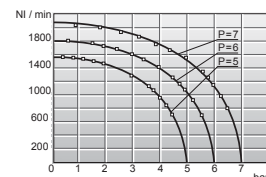
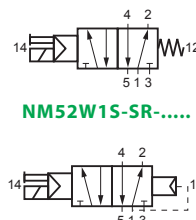

AIR FLOW DIAGRAM
 DIAGRAMMA DELLE PORTATE

NM52W1S-SR-.....
NM52W1S-PR-.....

CODES / CODICI

Ordination code	Voltage
NM52W1S - .R - 00000	No coil / Senza solenoide
NM52W1S - .R - 01200	12 V DC
NM52W1S - .R - 02400	24 V DC
NM52W1S - .R - 02450	24 V 50/60Hz AC
NM52W1S - .R - 11550	115 V 50/60Hz AC
NM52W1S - .R - 22050	220 V 50/60Hz AC

VALVE / 5/2
 DOUBLE SOLENOID VALVE
 DOPPIO COMANDO ELETTROPNEUMATICO

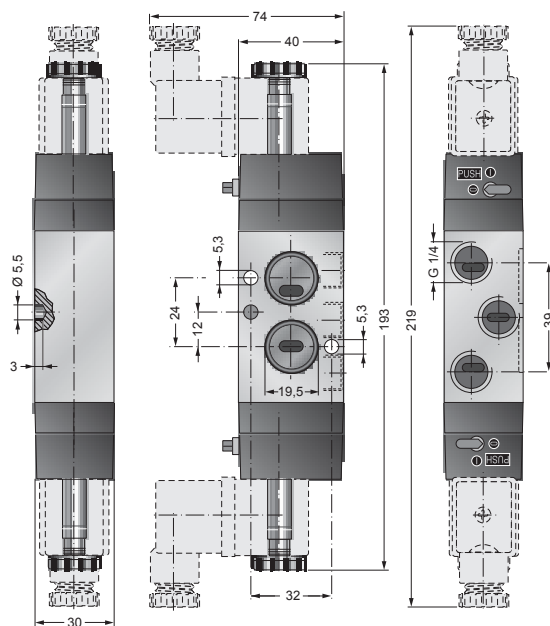

NM52W2S TP -.....

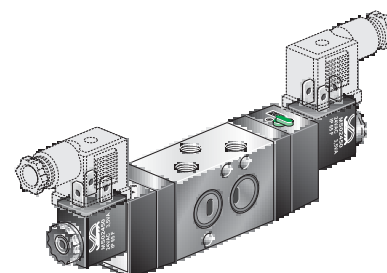

SIMBOL / SIMBOLO

DIAGRAM / DIAGRAMMA

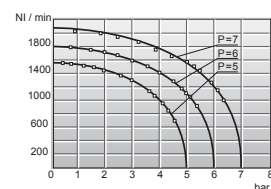
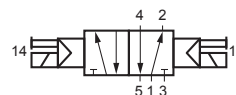

AIR FLOW DIAGRAM
 DIAGRAMMA DELLE PORTATE

CODES / CODICI

Ordination code	Voltage
Codice ordinazione	Tensione
NM52W2S - TP - 00000	No coils / Senza solenoidi
NM52W2S - TP - 01200	12 V DC
NM52W2S - TP - 02400	24 V DC
NM52W2S - TP - 02450	24 V 50/60Hz AC
NM52W2S - TP - 11550	115 V 50/60Hz AC
NM52W2S - TP - 22050	220 V 50/60Hz AC

VALVOLE ELETTROVALVOLE - VALVES AND SOLENOID VALVES